

IAEA SAFETY STANDARDS SERIES

Advisory Material for the
IAEA Regulations for the
Safe Transport of
Radioactive Material

SAFETY GUIDE

No. TS-G-1.1 (ST-2)



INTERNATIONAL
ATOMIC ENERGY AGENCY
VIENNA

IAEA SAFETY RELATED PUBLICATIONS

IAEA SAFETY STANDARDS

Under the terms of Article III of its Statute, the IAEA is authorized to establish standards of safety for protection against ionizing radiation and to provide for the application of these standards to peaceful nuclear activities.

The regulatory related publications by means of which the IAEA establishes safety standards and measures are issued in the **IAEA Safety Standards Series**. This series covers nuclear safety, radiation safety, transport safety and waste safety, and also general safety (that is, of relevance in two or more of the four areas), and the categories within it are **Safety Fundamentals**, **Safety Requirements** and **Safety Guides**.

Safety Fundamentals (blue lettering) present basic objectives, concepts and principles of safety and protection in the development and application of nuclear energy for peaceful purposes.

Safety Requirements (red lettering) establish the requirements that must be met to ensure safety. These requirements, which are expressed as 'shall' statements, are governed by the objectives and principles presented in the Safety Fundamentals.

Safety Guides (green lettering) recommend actions, conditions or procedures for meeting safety requirements. Recommendations in Safety Guides are expressed as 'should' statements, with the implication that it is necessary to take the measures recommended or equivalent alternative measures to comply with the requirements.

The IAEA's safety standards are not legally binding on Member States but may be adopted by them, at their own discretion, for use in national regulations in respect of their own activities. The standards are binding on the IAEA in relation to its own operations and on States in relation to operations assisted by the IAEA.

Information on the IAEA's safety standards programme (including editions in languages other than English) is available at the IAEA Internet site

www.iaea.org/ns/coordinet

or on request to the Safety Co-ordination Section, IAEA, P.O. Box 100, A-1400 Vienna, Austria.

OTHER SAFETY RELATED PUBLICATIONS

Under the terms of Articles III and VIII.C of its Statute, the IAEA makes available and fosters the exchange of information relating to peaceful nuclear activities and serves as an intermediary among its Member States for this purpose.

Reports on safety and protection in nuclear activities are issued in other series, in particular the **IAEA Safety Reports Series**, as informational publications. Safety Reports may describe good practices and give practical examples and detailed methods that can be used to meet safety requirements. They do not establish requirements or make recommendations.

Other IAEA series that include safety related sales publications are the **Technical Reports Series**, the **Radiological Assessment Reports Series** and the **INSAG Series**. The IAEA also issues reports on radiological accidents and other special sales publications. Unpriced safety related publications are issued in the **TECDOC Series**, the **Provisional Safety Standards Series**, the **Training Course Series**, the **IAEA Services Series** and the **Computer Manual Series**, and as **Practical Radiation Safety Manuals** and **Practical Radiation Technical Manuals**.

ADVISORY MATERIAL FOR THE
IAEA REGULATIONS FOR THE
SAFE TRANSPORT OF
RADIOACTIVE MATERIAL

The following States are Members of the International Atomic Energy Agency:

AFGHANISTAN	GHANA	PANAMA
ALBANIA	GREECE	PARAGUAY
ALGERIA	GUATEMALA	PERU
ANGOLA	HAITI	PHILIPPINES
ARGENTINA	HOLY SEE	POLAND
ARMENIA	HUNGARY	PORTUGAL
AUSTRALIA	ICELAND	QATAR
AUSTRIA	INDIA	REPUBLIC OF MOLDOVA
AZERBAIJAN	INDONESIA	ROMANIA
BANGLADESH	IRAN, ISLAMIC REPUBLIC OF	RUSSIAN FEDERATION
BELARUS	IRAQ	SAUDI ARABIA
BELGIUM	IRELAND	SENEGAL
BENIN	ISRAEL	SIERRA LEONE
BOLIVIA	ITALY	SINGAPORE
BOSNIA AND HERZEGOVINA	JAMAICA	SLOVAKIA
BOTSWANA	JAPAN	SLOVENIA
BRAZIL	JORDAN	SOUTH AFRICA
BULGARIA	KAZAKHSTAN	SPAIN
BURKINA FASO	KENYA	SRI LANKA
CAMBODIA	KOREA, REPUBLIC OF	SUDAN
CAMEROON	KUWAIT	SWEDEN
CANADA	LATVIA	SWITZERLAND
CENTRAL AFRICAN REPUBLIC	LEBANON	SYRIAN ARAB REPUBLIC
CHILE	LIBERIA	TAJIKISTAN
CHINA	LIBYAN ARAB JAMAHIRIYA	THAILAND
COLOMBIA	LIECHTENSTEIN	THE FORMER YUGOSLAV REPUBLIC OF MACEDONIA
COSTA RICA	LITHUANIA	TUNISIA
CÔTE D'IVOIRE	LUXEMBOURG	TURKEY
CROATIA	MADAGASCAR	UGANDA
CUBA	MALAYSIA	UKRAINE
CYPRUS	MALI	UNITED ARAB EMIRATES
CZECH REPUBLIC	MALTA	UNITED KINGDOM OF GREAT BRITAIN AND NORTHERN IRELAND
DEMOCRATIC REPUBLIC OF THE CONGO	MARSHALL ISLANDS	UNITED REPUBLIC OF TANZANIA
DENMARK	MAURITIUS	UNITED STATES OF AMERICA
DOMINICAN REPUBLIC	MEXICO	URUGUAY
ECUADOR	MONACO	UZBEKISTAN
EGYPT	MONGOLIA	VENEZUELA
EL SALVADOR	MOROCCO	VIET NAM
ESTONIA	MYANMAR	YEMEN
ETHIOPIA	NAMIBIA	YUGOSLAVIA, FEDERAL REPUBLIC OF
FINLAND	NETHERLANDS	ZAMBIA
FRANCE	NEW ZEALAND	ZIMBABWE
GABON	NICARAGUA	
GEORGIA	NIGER	
GERMANY	NIGERIA	
	NORWAY	
	PAKISTAN	

The Agency's Statute was approved on 23 October 1956 by the Conference on the Statute of the IAEA held at United Nations Headquarters, New York; it entered into force on 29 July 1957. The Headquarters of the Agency are situated in Vienna. Its principal objective is "to accelerate and enlarge the contribution of atomic energy to peace, health and prosperity throughout the world".

© IAEA, 2002

Permission to reproduce or translate the information contained in this publication may be obtained by writing to the International Atomic Energy Agency, Wagramer Strasse 5, P.O. Box 100, A-1400 Vienna, Austria.

Printed by the IAEA in Austria
June 2002
STI/PUB/1109

SAFETY STANDARDS SERIES No. TS-G-1.1 (ST-2)

ADVISORY MATERIAL FOR THE
IAEA REGULATIONS FOR THE
SAFE TRANSPORT OF
RADIOACTIVE MATERIAL

SAFETY GUIDE

INTERNATIONAL ATOMIC ENERGY AGENCY
VIENNA, 2002

VIC Library Cataloguing in Publication Data

Advisory material for the IAEA regulations for the safe transport of radioactive material : safety guide. — Vienna : International Atomic Energy Agency, 2002.

p. ; 24 cm. — (Safety standards series, ISSN 1020-525X;
no. TS-G-1.1 (ST-2))

STI/PUB/1109

ISBN 92-0-111802-3

Includes bibliographical references.

1. Radioactive substances — Transportation — Safety regulations.
I. International Atomic Energy Agency. II. Series.

VICL

02-00271

FOREWORD

by Mohamed ElBaradei
Director General

One of the statutory functions of the IAEA is to establish or adopt standards of safety for the protection of health, life and property in the development and application of nuclear energy for peaceful purposes, and to provide for the application of these standards to its own operations as well as to assisted operations and, at the request of the parties, to operations under any bilateral or multilateral arrangement, or, at the request of a State, to any of that State's activities in the field of nuclear energy.

The following bodies oversee the development of safety standards: the Commission for Safety Standards (CSS); the Nuclear Safety Standards Committee (NUSSC); the Radiation Safety Standards Committee (RASSC); the Transport Safety Standards Committee (TRANSSC); and the Waste Safety Standards Committee (WASSC). Member States are widely represented on these committees.

In order to ensure the broadest international consensus, safety standards are also submitted to all Member States for comment before approval by the IAEA Board of Governors (for Safety Fundamentals and Safety Requirements) or, on behalf of the Director General, by the Publications Committee (for Safety Guides).

The IAEA's safety standards are not legally binding on Member States but may be adopted by them, at their own discretion, for use in national regulations in respect of their own activities. The standards are binding on the IAEA in relation to its own operations and on States in relation to operations assisted by the IAEA. Any State wishing to enter into an agreement with the IAEA for its assistance in connection with the siting, design, construction, commissioning, operation or decommissioning of a nuclear facility or any other activities will be required to follow those parts of the safety standards that pertain to the activities to be covered by the agreement. However, it should be recalled that the final decisions and legal responsibilities in any licensing procedures rest with the States.

Although the safety standards establish an essential basis for safety, the incorporation of more detailed requirements, in accordance with national practice, may also be necessary. Moreover, there will generally be special aspects that need to be assessed on a case by case basis.

The physical protection of fissile and radioactive materials and of nuclear power plants as a whole is mentioned where appropriate but is not treated in detail; obligations of States in this respect should be addressed on the basis of the relevant instruments and publications developed under the auspices of the IAEA. Non-radiological aspects of industrial safety and environmental protection are also not explicitly considered; it is recognized that States should fulfil their international undertakings and obligations in relation to these.

The requirements and recommendations set forth in the IAEA safety standards might not be fully satisfied by some facilities built to earlier standards. Decisions on the way in which the safety standards are applied to such facilities will be taken by individual States.

The attention of States is drawn to the fact that the safety standards of the IAEA, while not legally binding, are developed with the aim of ensuring that the peaceful uses of nuclear energy and of radioactive materials are undertaken in a manner that enables States to meet their obligations under generally accepted principles of international law and rules such as those relating to environmental protection. According to one such general principle, the territory of a State must not be used in such a way as to cause damage in another State. States thus have an obligation of diligence and standard of care.

Civil nuclear activities conducted within the jurisdiction of States are, as any other activities, subject to obligations to which States may subscribe under international conventions, in addition to generally accepted principles of international law. States are expected to adopt within their national legal systems such legislation (including regulations) and other standards and measures as may be necessary to fulfil all of their international obligations effectively.

EDITORIAL NOTE

An appendix, when included, is considered to form an integral part of the standard and to have the same status as the main text. Annexes, footnotes and bibliographies, if included, are used to provide additional information or practical examples that might be helpful to the user.

The safety standards use the form 'shall' in making statements about requirements, responsibilities and obligations. Use of the form 'should' denotes recommendations of a desired option.

The English version of the text is the authoritative version.

PREFACE

This Advisory Material is not a stand-alone text. It only has significance when used concurrently as a companion to the IAEA Safety Standards Series No. ST-1¹, *Regulations for the Safe Transport of Radioactive Material* (1996 edition), denoted henceforth as “the Regulations”. To facilitate cross-reference between it and the Regulations, each paragraph of the Advisory Material is numbered in correspondence with the paragraph of the Regulations to which it most directly relates. To distinguish paragraphs of the Advisory Material from those of the Regulations for reference purposes, Advisory Material paragraphs always have a numeral after the decimal point, even when there is only one subparagraph of text. Thus, for example, advice relating to para. 401 of the Regulations should be initially sought under para. 401.1 of the Advisory Material. Integral paragraph numbers which are cited in the text, either alone or accompanied by lower case letters in brackets, should be taken as identifying paragraphs of the Regulations.

Also, the publications listed under “References” are the versions which were used in the development of the 1996 edition of the Regulations and this Advisory Material. Some of the publications may have been superseded by later revisions. These may be consulted for the most recent information recognizing that the earlier editions are the basis for the discussions which follow.

Since the first edition in 1961, the Regulations for the Safe Transport of Radioactive Material of the International Atomic Energy Agency (IAEA Regulations) have served as the basis of safety for the transport of radioactive material worldwide. The provisions of the IAEA Regulations have been adopted in national regulations by most of the Member States of the Agency. The international regulatory bodies having responsibility for the various modes of transport have also implemented the IAEA Regulations. The safety record since the inception, and throughout several comprehensive revisions, of the Regulations has demonstrated the efficacy both of the regulatory provisions and of the arrangements for ensuring compliance with them.

In the discussions leading to the first edition of the IAEA Regulations, it was realized that there was need for a publication to supplement the Regulations which could give information on individual provisions as to their purpose, their scientific background and how to apply them in practice. The scientific basis of the classification of radioisotopes for transport purposes, then in use, and the factors that

¹ The *Regulations for the Safe Transport of Radioactive Material* were issued in 1996 as Safety Standards Series No. ST-1. In 2000 the Regulations were issued in English, with minor editorial corrections, as Safety Standards Series No. TS-R-1 (ST-1, Revised).

have to be taken into account by competent authorities in approving package designs, were examples adduced in support of this concept at the time. In response, the Agency published Safety Series No. 7, entitled, in its first edition in 1961, “Notes on Certain Aspects of the Regulations”.

As experience in applying the Regulations grew, it became increasingly evident that, while the provisions of the Regulations might be essentially clear and unambiguous, nevertheless they would often also be highly technical in nature and unavoidably complex. Moreover they intentionally state no more than ‘what’ must be achieved in relation to package characteristics and operational conditions in order to assure safety. They do not seek to prescribe ‘how’ the user should comply; indeed the freedom to innovate and to develop new ways to ensure compliance is recognized as intrinsically desirable in such a technically advanced field. An additional source of information on the Regulations, providing advice on ‘how’ to comply with them which could be augmented from time to time in the light of latest experience, was therefore provided by the Agency, initially in relation to the 1973 edition of the Regulations. This was entitled “Advisory Material for the IAEA Regulations for the Safe Transport of Radioactive Material”. It was designated Safety Series No. 37.

Up to the time of publication of the previous edition of the IAEA Regulations, in 1985, Safety Series No. 37 had reached its third edition. Meanwhile, Safety Series No. 7, which embodied information on the scientific basis and rationale of the Regulations, had been retitled “Explanatory Material for the IAEA Regulations for the Safe Transport of Radioactive Material” and, embodying mainly information on the scientific basis and rationale of the Regulations, was in its second edition.

During the current regulatory revision, which culminated in 1996, the Agency’s senior advisory body for transport, the Transport Safety Standards Advisory Committee (TRANSSAC), in consultation with the Agency’s Publishing Section, agreed that it would be a useful simplification to combine the two Safety Guides previously known as Safety Series No. 7 and Safety Series No. 37 in a single publication, to be known as “Advisory Material for the IAEA Regulations for the Safe Transport of Radioactive Material”. This would have the advantage of consolidating supporting information on the Regulations in one place, eliminating duplication. The advisory nature of the present publication has been made paramount. The inclusion of some explanatory material supports this function since a proper understanding of the background to the regulatory provisions helps users to interpret them correctly and to comply with them fully.

Thus the primary purpose of this publication (henceforth referred to as the Advisory Material) is to provide guidance to users on proven and acceptable ways of complying with and demonstrating compliance with the Regulations. It must be emphasized that the text is not to be construed as being uniquely prescriptive. It offers recommendations on ways of complying but it does not lay down ‘the only way’ to comply with any specific provision.

Member States and international organizations are invited to take note of this publication and to bring it to the attention of persons and organizations who make use of, or are subject to, the IAEA Regulations. Moreover, readers are encouraged to send, through their competent authority, any comments they may wish to make, including proposals for modifications, additions or deletions, to the International Atomic Energy Agency.

CONTENTS

SECTION I.	INTRODUCTION	1
	Background	1
	Objective	1
	Scope	1
	Reference to Section I	3
SECTION II.	DEFINITIONS	5
	References to Section II	28
SECTION III.	GENERAL PROVISIONS	29
	Radiation protection	29
	Emergency response	34
	Quality assurance	35
	Compliance assurance	36
	Special arrangement	38
	References to Section III	39
SECTION IV.	ACTIVITY LIMITS AND MATERIAL RESTRICTIONS	41
	Basic radionuclide values	41
	Determination of basic radionuclide values	43
	Contents limits for packages	44
	References to Section IV	48
SECTION V.	REQUIREMENTS AND CONTROLS FOR TRANSPORT	51
	Requirements before the first shipment	51
	Requirements before each shipment	53
	Transport of other goods	55
	Other dangerous properties of contents	56
	Requirements and controls for contamination and for leaking packages	57
	Requirements and controls for transport of excepted packages	63

Requirements and controls for transport of LSA material and SCO	
in industrial packages or unpackaged	67
Determination of transport index	68
Determination of criticality safety index	70
Limits on transport index, criticality safety index and	
radiation levels for packages and overpacks	71
Categories	71
Marking, labelling and placarding	73
Consignor's responsibilities	79
Transport and storage in transit	82
Customs operations	93
Undeliverable consignments	94
References to Section V	94

SECTION VI. REQUIREMENTS FOR RADIOACTIVE MATERIALS AND FOR PACKAGINGS AND PACKAGES 97

Requirements for radioactive materials	97
General requirements for all packagings and packages	101
Additional requirements for packages transported by air	104
Requirements for excepted packages	105
Requirements for industrial packages	105
Requirements for packages containing uranium hexafluoride	110
Requirements for Type A packages	113
Requirements for Type B(U) packages	119
Requirements for Type B(M) packages	134
Requirements for Type C packages	136
Requirements for packages containing fissile material	137
References to Section VI	148

SECTION VII. TEST PROCEDURES 153

Demonstration of compliance	153
Tests for special form radioactive material	160
Tests for low dispersible radioactive material	162
Tests for packages	163
References to Section VII	194

SECTION VIII. APPROVAL AND ADMINISTRATIVE REQUIREMENTS	199
General aspects	199
Approval of special form radioactive material and low dispersible radioactive material	200
Approval of package designs	200
Transitional arrangements	202
Notification and registration of serial numbers	206
Approval of shipments	207
Approval of shipments under special arrangement	208
Competent authority approval certificates	209
Contents of approval certificates	210
Validation of certificates	213
Reference to Section VIII	214
APPENDIX I: THE Q SYSTEM FOR THE CALCULATION AND APPLICATION OF A_1 AND A_2 VALUES	215
Introduction	215
Background	216
Basis of the Q system	217
Dosimetric models and assumptions	219
Special considerations	229
Applications	233
Tabulation of Q values	237
Decay chains used in the Q system	252
Conclusions	252
References to Appendix I	255
APPENDIX II: HALF-LIFE AND SPECIFIC ACTIVITY OF RADIONUCLIDES, DOSE AND DOSE RATE COEFFICIENTS OF RADIONUCLIDES AND SPECIFIC ACTIVITY	259
Reference to Appendix II	285
APPENDIX III: EXAMPLE CALCULATIONS FOR ESTABLISHING MINIMUM SEGREGATION DISTANCE REQUIREMENTS	287

Introduction	287
Below main deck stowage of one group of packages in passenger aircraft	289
Below main deck stowage of multiple groups of packages in passenger aircraft	292
Main deck stowage on combi or cargo aircraft	294
Segregation distances for undeveloped film	295
References to Appendix III	295

APPENDIX IV: QUALITY ASSURANCE IN THE SAFE TRANSPORT
 OF RADIOACTIVE MATERIAL 297

Introduction	297
Quality assurance programmes	301
Organization	302
Document control	303
Design control	304
Procurement control	306
Material control	307
Process control	307
Inspection and test control	308
Non-conformity control	310
Corrective actions	310
Records	310
Staff and training	311
Servicing	311
Audits	311
Definitions of terms used in Appendix IV	312
References to Appendix IV	313

APPENDIX V: PACKAGE STOWAGE AND RETENTION
 DURING TRANSPORT 315

Introduction	315
Types of retention system	315
Package acceleration factor considerations	317
Demonstrating compliance through testing	319
Examples of retention system designs and assessments	320
Definitions of terms used in Appendix V	326
References to Appendix V	327

APPENDIX VI: GUIDELINES FOR SAFE DESIGN OF SHIPPING PACKAGES AGAINST BRITTLE FRACTURE	329
Introduction	329
General consideration of evaluation methods	330
Considerations for fracture mechanics	334
Safety factors for Method 3	337
Evaluation procedure for Method 3	339
References to Appendix VI	344
APPENDIX VII: CRITICALITY SAFETY ASSESSMENTS	347
Introduction	347
Package description	347
Criticality safety analysis models	348
Method of analysis	350
Validation of calculational method	352
Calculations and results	358
Special issues	365
Design and operational issues	368
References to Appendix VII	370
CONTRIBUTORS TO DRAFTING AND REVIEW	375
BODIES FOR THE ENDORSEMENT OF SAFETY STANDARDS	380
INDEX	382

LIST OF TABLES

Table I	Correction factors for package and detector sizes	22
Table II	Sample segregation between classes of dangerous goods ...	85
Table III	Comparison of the four volumetric leak test methods recommended by Aston et al. [3]	98
Table IV	List of VRI codes by country	211
Table I.1	Dose coefficients for submersion	229
Table I.2	Type A package contents limits	238
Table I.3	Decay chains used in the Q system	253
Table II.1	Half-life and specific activity of radionuclides	259
Table II.2	Dose and dose rate coefficients of radionuclides	272

Table II.3	Specific activity values for uranium at various levels of enrichment	286
Table III.1	Transmission factors	290
Table III.2	Variation of segregation distance with transport index for a single group of packages stowed below main deck on a passenger aircraft	291
Table III.3	Variation of segregation distance with transport index for main deck stowage on a combi or cargo aircraft	294
Table IV.1	Basic elements of quality assurance programmes that should be considered and addressed in the safe transport of radioactive material	300
Table V.1	Acceleration factors for package retention system design	318
Table V.2	Acceleration factors for package retention system design for specific packages	319
Table V.3	Symbols used in calculation of a rectangular package with baseplate flange bolted to the conveyance	325

Section I

INTRODUCTION

BACKGROUND

103.1. When making national or international shipments it is necessary to consult the Regulations for the particular mode of transport to be used for the countries where the shipment will be made. While most of the major requirements are in agreement with the Regulations, there can be differences with respect to the assignment of responsibilities for carrying out specific actions. For air shipments, the International Civil Aviation Organization's (ICAO) Technical Instructions for the Safe Transport of Dangerous Goods by Air and the International Air Transport Association's (IATA) Dangerous Goods Regulations should be consulted, with particular regard to the State and operator variations. For sea shipments, the International Maritime Organization's (IMO) International Maritime Dangerous Goods (IMDG) Code should be consulted. Some countries have adopted the Regulations by reference while others have incorporated them into their national regulations with possibly some minor variations.

OBJECTIVE

104.1. In general the Regulations aim to provide a uniform and adequate level of safety that is commensurate with the inherent hazard presented by the radioactive material being transported. To the extent feasible, safety features are required to be built into the design of the package. By placing primary reliance on the package design and preparation, the need for any special actions during carriage, i.e. by the carrier, is minimized. Nevertheless, some operational controls are required for safety purposes.

SCOPE

106.1. Transport includes carriage by a common carrier or by the owner or employee where the carriage is incidental to the use of the radioactive materials, such as vehicles carrying radiography devices being driven to and from the operations site by the radiographer, vehicles carrying density measuring gauges being driven to and from the construction site, and oil well logging vehicles carrying measuring devices containing radioactive materials and radioactive materials used in oil well injections.

107.1. The Regulations are not intended to be applied to movements of radioactive material that forms an integral part of a means of transport, such as depleted uranium counterweights or tritium exit signs used in aircraft; or to radioactive material in persons or animals for medical or veterinary purposes, such as cardiac pacemakers or radioactive material introduced into humans or animals for diagnosis or treatment. The treating physician or veterinarian should give appropriate advice on radiological safety.

107.2. Consumer products are items available to the general public as the end user without further control or restriction. These may be devices such as smoke detectors, luminous dials or ion generating tubes that contain small amounts of radioactive substances. Consumer products are outside the scope of the Regulations only after sale to the end user. Any transport, including the use of conveyances between manufacturers, distributors and retailers, is within the scope of the Regulations to ensure that large quantities of individually exempted consumer products are not transported in an unregulated manner.

107.3. The principles of exemption and their application to the transport of radioactive material are dealt with in para. 401.

107.4. The scope of the Regulations includes consideration of those natural materials or ores which form part of the nuclear fuel cycle or which will be processed in order to use their radioactive properties. The Regulations do not apply to other ores which may contain naturally occurring radionuclides, but whose usefulness does not lie in the fissile, fertile or radioactive properties of those nuclides, provided that the activity concentration does not exceed 10 times the exempt activity concentration values. In addition, the Regulations do not apply to natural materials and ores containing naturally occurring radionuclides which have been processed (up to 10 times the exempt activity concentration values) where the physical and/or chemical processing was not for the purpose of extracting radionuclides, e.g. washed sands and tailings from alumina refining. Were this not the case, the Regulations would have to be applied to enormous quantities of material that present a very low hazard. However, there are ores in nature where the activity concentration is much higher than the exemption values. The regular transport of these ores may require consideration of radiation protection measures. Hence, a factor of 10 times the exemption values for activity concentration was chosen as providing an appropriate balance between the radiological protection concerns and the practical inconvenience of regulating large quantities of material with low activity concentrations of naturally occurring radionuclides.

108.1. Although these Regulations provide for the requisite safety in transport without the need for specified routing, the regulatory authorities in some Member

States have imposed routing requirements. In prescribing routes, normal and accident risks, both radiological and non-radiological, as well as demographic considerations should be taken into account. Policies embodied in the routing restrictions should be based upon all factors that contribute to the overall risk in transporting radioactive material and not only on concerns for 'worst case' scenarios, i.e. 'low probability/high consequence' accidents. Since the authorities at the State, provincial or even local levels may be involved in routing decisions, it may often be necessary to provide them with either evaluations to assess alternative routes or with very simple methods which they can use.

108.2. In assessing the radiological hazards and ensuring that the routing requirements do not detract from the standards of safety specified in the Regulations, analyses using appropriate risk assessment codes should be undertaken. One such code which may be used, INTERTRAN [1], was developed through a co-ordinated research programme of the IAEA. This computer based environmental impact code is available for use by Member States. In spite of many uncertainties stemming from the use of a generalized model and the difficulty of selecting appropriate input values for accident conditions, this code may be used to calculate and understand, at least on a qualitative basis, the factors significant in determining the radiological impact from routing alternatives involving the transport of radioactive material. These factors are the important aspects that should be considered in any routing decision. For routing decisions involving a single mode of transport, many simplifying assumptions can be made and common factors can be assigned which result in easy to use relative risk evaluation techniques.

108.3. The consignor may also be required to provide evidence that measures to meet the requirements for safeguards and physical protection associated with radioactive nuclear material shipments are being complied with.

109.1. See paras 506 and 507.

REFERENCE TO SECTION I

- [1] INTERNATIONAL ATOMIC ENERGY AGENCY, INTERTRAN: A System for Assessing the Impact from Transporting Radioactive Material, IAEA-TECDOC-287, IAEA, Vienna (1983).

Section II

DEFINITIONS

A₁ and A₂

201.1. See Appendix I.

Approval

204.1. The approval requirements in the Regulations have been graded according to the hazards posed by the radioactive material to be transported. Approval is intended to ensure that the design meets the relevant requirements and that the controls required for safety are adequate for the country and for the circumstances of the shipment. Since transport operations and conditions vary between countries, application of the ‘multilateral approval’ approach provides the opportunity for each competent authority to satisfy itself that the shipment is to be properly performed, with due account taken of any peculiar national conditions.

204.2. The concept of multilateral approval applies to transport as it is intended to occur. This means that only those competent authorities through whose jurisdiction the shipment is scheduled to be transported are involved in its approval. Unplanned deviations which occur during transport and which result in the shipment entering a country where the transport had not previously been approved would need to be handled individually. For this reason the definition of multilateral approval is limited to countries “through or into which the consignment is transported” and specifically excludes countries over which the shipment may be transported by aircraft. The countries that will be flown over are often not known until the aircraft is in the air and receives an air traffic control clearance. If an aircraft is scheduled to stop in a country, however, multilateral approval includes approval by the competent authority of that country.

204.3. Users of the Regulations should be aware that a Member State may require in its national regulations that an additional approval be given by its competent authority for any special form radioactive material, Type B(U) and Type C package which is to be used for domestic transport on its territory, even if the design has already been approved in another country.

205.1. For unilateral approval it is believed that the Regulations take into account the transport conditions which may be encountered in any country. Consequently,

only approval by the competent authority of the country of origin of the design is required.

Carrier

206.1. The term ‘person’ includes a body corporate as well as an individual (see also the Basic Safety Standards (BSS) [1], paras 2.10–2.14).

Competent authority

207.1. The competent authority is the organization defined by legislative or executive authority to act on behalf of a country, or an international authority, in matters involving the transport of radioactive material. The legal framework of a country determines how a national competent authority is designated and is given the responsibility to ensure application of the Regulations. In some instances, authority over different aspects of the Regulations is assigned to different agencies, depending on the transport mode (air, road, rail, sea or inland waterway) or the package and radioactive material type (excepted, industrial, Type A, Type B and Type C packages; special form radioactive material, low dispersible material; fissile material or uranium hexafluoride). A national competent authority may in some cases delegate the approval of package designs and certain types of shipment to another organization having the necessary technical competence. National competent authorities also constitute the competent authorities referred to in any conventions or agreements on the transport of radioactive material to which the country adheres.

207.2. The competent authority should make the consignors, carriers, consignees and public aware of its identity and how it may be contacted. This may be accomplished by publishing the organizational identity (department, administration, office, etc.), with a description of the duties and activities of the organization in question as well as detailed mailing address, telephone and facsimile numbers, email address, etc.

207.3. The primary source of competent authority identifications is the list of National Competent Authorities Responsible for Approvals and Authorizations in Respect of the Transport of Radioactive Material, which is published annually by the IAEA and is available on request. Each country should ensure that the listed information is current and accurate. The IAEA requests verification of this information annually, and prompt responses by Member States will ensure the continued value of this list.

Compliance assurance

208.1. See paras 311.1–311.9.

Confinement system

209.1. The confinement system should be that part of a package necessary to maintain the fissile material in the configuration that was assumed in the criticality safety assessment for an individual package (see para. 678). The confinement system could be (1) an inner receptacle with defined dimensions, (2) an inner structure maintaining the outer dimension of a fuel assembly and any interstitial fixed poisons, or (3) a complete package such as an irradiated nuclear fuel package with no inner container. The confinement system consists of specified packaging components and the package contents. Although the confinement system may have the same boundary as the containment system, this is not always the case since the confinement system maintains criticality control whereas the containment system prevents leakage of radioactive material. Each competent authority must concur that the confinement system defined in the criticality safety assessment is appropriate for the package design, for both damaged and undamaged configurations (see para. 678).

Containment system

213.1. The containment system can be the entire packaging but, more frequently, it makes up a portion of the packaging. For example, in a Type A package the containment system may be considered to be the vial containing the radioactive contents. The vial, its enclosing lead pot shielding and fibreboard box make up the packaging. The containment system does not necessarily include the shielding. In the case of special form radioactive material and low dispersible radioactive material, the radioactive material may be part of the containment system (see para. 640).

213.2. The leaktightness requirement for a containment system in a Type B(U), Type B(M) or Type C package depends on the radiotoxicity of the radioactive contents; for example, a Type B(U) or Type C package under accident conditions must have the release limited to a value of A_2 in the period of a week. This connection to the A_2 value means that for highly toxic radionuclides such as plutonium and americium the allowable volumetric leak rate will be much lower than for low enriched uranium. However, if fissile material is able to escape from the containment system under accident conditions, it must be demonstrated that the quantity that escapes is consistent with that assumed in the criticality safety assessment in applying para. 682(c).

Contamination

214.1. Contamination includes two types of radioactive material on surfaces or embedded in surfaces, namely fixed contamination and non-fixed contamination. There is no definitive distinction between fixed and non-fixed contamination, and various terms have been used to describe the distinction. For practical purposes a distinction is made between contamination which, during routine conditions of transport, remains in situ (i.e. fixed contamination) and, therefore, cannot give rise to hazards from ingestion, inhalation or spreading, and non-fixed contamination which may contribute to these hazards. The only hazard from fixed contamination is that due to external radiation exposure, whereas the hazards from non-fixed contamination include the potential for internal exposure from inhalation and ingestion as well as external exposure due to contamination of the skin should it be released from the surface. Under accident conditions, and under certain use conditions such as weathering, fixed contamination may, however, become non-fixed contamination.

214.2. Contamination below levels of 0.4 Bq/cm^2 for beta and gamma emitters and for low toxicity alpha emitters, or 0.04 Bq/cm^2 for all other alpha emitters (see also para. 508), can give rise only to insignificant exposure through any of these pathways.

214.3. Any surface with levels of contamination lower than 0.4 Bq/cm^2 for beta and gamma emitters and low toxicity alpha emitters or 0.04 Bq/cm^2 for all other alpha emitters is considered a non-contaminated surface in applying the Regulations. For instance, a non-radioactive solid object with levels of surface contamination lower than the above levels is out of the scope of the Regulations, and no requirement is applicable to its transport.

215.1. See paras 214.1–214.3.

216.1. See paras 214.1–214.3.

Criticality safety index

218.1. The criticality safety index (CSI) is a new term defined for the first time in the 1996 edition of the Regulations. The 1973 and 1985 editions of the Regulations used the ‘transport index’ for both radiological control and control of criticality safety of packages containing fissile material. These editions of the Regulations defined the transport index (TI) so that a single number accommodated both radiological safety and criticality safety considerations. As the operational controls needed for radiological protection and for criticality safety are essentially independent, this edition of the Regulations has separated the CSI from the TI, which is now defined (see para. 243) for

radiological control only. This separation into two indices enables a clear recognition of the basis for operational control of a fissile package and eliminates potential unnecessary restrictions caused by the use of one index. However, with this new control, care should be taken not to confuse the ‘new TI’ and the ‘old TI’ used in the previous edition of the Regulations. Awareness of this change is necessary to ensure proper labelling for criticality safety (see paras 544 and 545) and criticality control for packages, overpacks and freight containers containing fissile material using the newly introduced CSI.

218.2. The CSI is a number used to control criticality safety for a shipment of fissile material and is obtained by dividing the number 50 by the value of N (see para. 528). The accumulation of packages containing fissile material is required to be controlled in individual consignments (see paras 529 and 530), in conveyances, freight containers and overpacks (see paras 566(d) and 567) and in-transit storage (see paras 568 and 569). To facilitate such control, the CSI is required to be displayed on a label (see paras 544 and 545) which is specifically designed to indicate the presence of fissile material in the case of packages, overpacks or freight containers where contents consist of fissile material not excepted under the provisions of para. 672.

Exclusive use

221.1. The special features of an ‘exclusive use’ shipment are, by definition, first, that a single consignor must make the shipment and must have, through arrangements with the carrier, sole use of the conveyance or large freight container; and, second, that all initial, intermediate and final loading and unloading of the consignment is carried out only in strict accordance with directions from the consignor or consignee.

221.2. Since ordinary in-transit handling of the consignment under exclusive use will not occur, some of the requirements which apply to normal shipments can be relaxed. In view of the additional control which is exercised over exclusive use consignments, specific provisions have been made for them which allow:

- Use of a lower integrity industrial package type for low specific activity (LSA) materials;
- Shipment of packages with radiation levels exceeding 2 mSv/h (but not more than 10 mSv/h) at the surface, or a TI exceeding 10;
- Increase by a factor of two in the total number of criticality safety indices for fissile material packages in a number of cases.

Many consignors find that it is advantageous to make the necessary arrangements with the carrier to provide transport under exclusive use so that the consignor can utilize one or more of the above provisions.

221.3. In the case of packaged LSA material, the Regulations take into account the controlled loading and unloading conditions which result from transport under exclusive use. The additional controls imposed under exclusive use are to be in accordance with instructions prepared by the consignor or consignee (both of whom have full information on the load and its potential hazards), allowing some reduction in packaging strength. Since uncontrolled handling of the packages does not occur under exclusive use, the conservatism which is embodied in the normal LSA packaging requirements regarding handling has been relaxed, but equivalent levels of safety are to be maintained.

221.4. Packages which may be handled during transport must necessarily have their allowable radiation levels limited to protect the workers handling them. The imposition of exclusive use conditions and the control of handling during transport help to ensure that proper radiation protection measures are taken. By imposing restrictions and placing a limit on the allowable radiation levels around the vehicle, the allowable radiation level of the package may be increased without significantly increasing the hazard.

221.5. Since exclusive use controls effectively prevent the unauthorized addition of radioactive materials to a consignment and provide a high level of control over the consignment by the consignor, allowances have been made in the Regulations to authorize more fissile material packages than for ordinary consignments.

221.6. For exclusive use of a conveyance or large freight container, the sole use requirement and the sole control requirement are the determining factors. Although a vehicle may be used to transport only radioactive material, this does not automatically qualify the consignment as exclusive use. In order to meet the definition of exclusive use, the entire consignment has to originate from or be controlled by a single consignor. This excludes the practice of a carrier collecting consignments from several consignors in a single vehicle. Even though the carrier is consolidating the multiple consignments onto one vehicle, it is not in exclusive use because more than one consignor is involved. However, this does not preclude a properly qualified carrier or consignee who is consolidating shipments from more than one source from taking on the responsibilities of the consignor for these shipments and from being so designated.

Fissile material

222.1. A fission chain is propagated by neutrons. Since a chain reaction depends on the behaviour of neutrons, fissile material is packaged and shipped under requirements designed to maintain subcriticality and, thus, provide criticality safety in transport. In the Regulations the term 'fissile material' is occasionally used to refer both to fissile

radionuclides and to material containing these radionuclides. Users of the Regulations should remain alert to the context in which the term 'fissile material' is used.

222.2. Most radionuclides can be made to fission, but many can only be made to fission with difficulty and with special equipment and controlled conditions. The distinguishing characteristic of the fissile nuclides implied by the definition is that they are capable of supporting a self-sustaining thermal neutron (neutron energies less than approximately 0.3 eV) chain reaction by only the accumulation of sufficient mass. No other action, mechanism or special condition is required. For example, Pu-238 is no longer listed in the definition because, although it can be made to support a fast neutron chain reaction under stringent laboratory conditions, in the form in which it is encountered in transport it does not have this property. Plutonium-238 cannot under any circumstances support a chain reaction carried by thermal neutrons. It is, therefore, 'fissionable' rather than 'fissile'.

222.3. As indicated in the above paragraph, the basis used to select the nuclides defined as fissile material for the purposes of the Regulations relies on the ease of accumulating sufficient mass for a potential criticality. Other actinides that have the potential for criticality are discussed in ANSI/ANS-8.15-1981 [2] and subcritical mass limits are provided for isolated units of Np-237, Pu-238, Pu-240, Pu-242, Am-241, Am-242m, Am-243, Cm-243, Cm-244, Cm-245, Cm-247, Cf-249 and Cf-251. The predicted subcritical mass limits for these materials range from a few grams (Cf-251) to tens of kilograms. However, the lack of critical experiment data, limited knowledge of the behaviour of these nuclides under different moderator and reflection conditions and the uncertainty in the cross-section data for many of these nuclides require that adequate attention (and associated subcritical margin) be provided to operations where sufficient quantities of these nuclides might be present (or produced by decay before or during transport). Advice of the competent authority should be sought on the need and means of performing a criticality safety assessment per the requirements of paras 671–682 whenever significant quantities of these materials may be transported.

Freight container

223.1. The methods and systems employed in the transshipment of goods have undergone a transformation since about 1965; the freight container has largely taken the place of parcelled freight or general cargo which was formerly loaded individually. Packaged as well as unpackaged goods are loaded by the consignor into freight containers and are transported to the consignee without intermediate handling. In this manner, the risk of damage to packages is reduced, unpackaged goods are consolidated into conveniently handled units and transport economies are realized. In the case of large articles such as

contaminated structural parts from nuclear power stations, the container may perform the function of the packaging as allowed under para. 627.

223.2. Freight containers are typically designed and tested in accordance with the standards of the International Organization for Standardization (ISO) [3]. They should be approved and maintained in accordance with the International Convention for Safe Containers (CSC) [4] in order to facilitate international transport operations. If other freight containers are used, the competent authority should be consulted. It should be noted, however, that the testing prescribed in CSC is not equivalent to that prescribed in ISO 1496/1. For this reason the Regulations require the design standard to be ISO.

223.3. In addition, special rules may be specified by modal transport organizations. As an example, the International Maritime Dangerous Goods (IMDG) Code [5] contains the provisions for the transport by sea of dangerous goods including radioactive material.

Low dispersible radioactive material

225.1. The concept of low dispersible radioactive material applies only to qualification for exemption from the requirements for Type C packages in the air transport mode.

225.2. Low dispersible radioactive material has properties such that it will not give rise to significant potential releases or exposures. Even when subjected to high velocity impact and thermal environments, only a limited fraction of the material will become airborne. Potential radiation exposure from inhalation of airborne material by persons in the vicinity of an accident would be very limited.

225.3. The low dispersible radioactive material criteria are derived in consistency with other safety criteria in the Regulations, as well as on the basis of established methods to demonstrate acceptable radiological consequences. The Regulations require that the performance of low dispersible material be demonstrated without taking any credit for the Type B packaging in which it is transported.

225.4. Low dispersible radioactive material may be the radioactive material itself, in the form of an indispersible solid, or a high integrity sealed capsule containing the radioactive material, in which the encapsulated material acts essentially as an indispersible solid. Powders and powder-like materials cannot qualify as low dispersible material.

Low specific activity material

226.1. The reason for the introduction of a category of LSA material into the IAEA Regulations was the existence of certain solid materials the specific activities of which are so low that it is highly unlikely that, under circumstances arising in transport, a sufficient mass of such materials could be taken into the body to give rise to a significant radiation hazard. Uranium and thorium ores and their physical or chemical concentrates are materials falling into this category. This concept was extended to include other solid materials, on the basis of a model which assumes that it is most unlikely that a person would remain in a dusty atmosphere long enough to inhale more than 10 mg of material. If the specific activity of the material is such that the mass intake is equivalent to the activity intake assumed to occur for a person involved in a median accident with a Type A package, namely $10^{-6} A_2$, then this material would not present a greater hazard during transport than that presented by a Type A package. This leads to a low specific activity material limit of $10^{-4} A_2/g$.

226.2. Consideration was given to the possibility of shipping solid objects without any packaging. The question arose for concrete blocks (with activity throughout the mass), for irradiated objects and for objects with fixed contamination. Under the condition that the specific activity is relatively low and remains in or fixed on the object's surface, the object can be dealt with as a package. For the sake of consistency and safety, the radiation limits at the surface of the unpackaged object should not exceed the limits for packaged material. Therefore, it was considered that above the limits of surface radiation levels for packages (2 mSv/h for non-exclusive use and 10 mSv/h for exclusive use) the object must be packaged in an industrial package which assures shielding retention in routine transport. Similar arguments were made for establishing surface contamination levels for unpackaged surface contaminated objects (SCOs).

226.3. The preamble to the LSA definition does not include the unshielded radiation level limit of 10 mSv/h at 3 m (see para. 521), because it is a property of the quantity of material placed in a single package rather than a property of the material itself (although in the case of solid objects which cannot be divided, it is a property of the solid object).

226.4. The preamble also does not include wording relative to the essentially uniform distribution of the radionuclides throughout the LSA material. However, it states clearly that the material should be in such a form that an average specific activity can be meaningfully assigned to it. In considering actual materials shipped as LSA, it was decided that the degree of uniformity of the distribution should vary depending upon

the LSA category. The degree of uniformity is thus specified, as necessary, for each LSA category (see, for example, para. 226(c)(i)).

226.5. LSA-I was introduced in the 1985 edition of the Regulations to describe very low specific activity materials. These materials may be shipped unpackaged, or they may be shipped in Industrial Packages Type 1 (Type IP-1) which are designed to minimal requirements (para. 621). According to para. 226(a)(i), LSA-I materials cannot consist of: concentrates of ores other than uranium or thorium concentrates (for example, radium ore concentrate cannot be LSA-I material), unless they meet para. 226(a)(iv). In the 1996 edition of the Regulations the LSA-I category was revised to take into account:

- the clarification of the scope of the Regulations concerning ores other than uranium and thorium ores according to para. 107(e);
- fissile materials in quantities excepted from the package requirements for fissile material according to para. 672;
- the introduction of new exemption levels according to para. 236.

The definition of LSA-I was consequently modified to:

- include only those ores containing naturally occurring radionuclides which are intended to be processed for the use of these radionuclides (para. 226(a)(i));
- exclude fissile material in quantities not excepted under para. 672 (para. 226(a)(iii)); and
- add radioactive material in which the activity is distributed throughout in concentrations up to 30 times the exemption level (para. 226(a)(iv)).

Materials containing radionuclides in concentrations above the exemption levels have to be regulated. It is reasonable that materials containing radionuclides up to 30 times the exemption level may be exempted from parts of the transport regulations and may be associated with the category of LSA-I materials. The factor of 30 has been selected to take account of the rounding procedure used in the derivation of the Basic Safety Standards [1] exemption levels and to give a reasonable assurance that the transport of such materials does not give rise to unacceptable doses.

226.6. Uranium enriched to 20% or less may be shipped as LSA-I material either in Type IP-1 packages or unpackaged in fissile excepted quantities. However, amounts exceeding fissile excepted quantities (see para. 672) will be subject to the requirements for packages containing fissile material, thus precluding transport of the material unpackaged, or in unapproved packages.

226.7. The materials expected to be transported as LSA-II could include nuclear reactor process wastes which are not solidified, such as lower activity resins and filter sludges, absorbed liquids and other similar materials from reactor operations, and similar materials from other fuel cycle operations. In addition, LSA-II could include many items of activated equipment from the decommissioning of nuclear plants. Since LSA-II materials could be available for human intake after an accident, the specific activity limit is based upon an assumed uptake by an individual of 10 mg. Since the LSA-II materials are recognized as being clearly not uniformly distributed (e.g. scintillation vials, hospital and biological wastes and decommissioning wastes), the allowed specific activity is significantly lower than that of LSA-III. The factor of 20 lower allowed specific activity as compared with the limit for LSA-III compensates for localized concentration effects of the non-uniformly distributed material.

226.8. While some of the materials considered to be appropriate for inclusion in the LSA-III category would be regarded as essentially uniformly distributed (such as concentrated liquids in a concrete matrix), other materials such as solidified resins and cartridge filters are distributed throughout the matrix but are uniformly distributed to a lesser degree. The solidification of these materials as a monolithic solid which is insoluble in water and non-flammable makes it highly unlikely that any significant portion of it will become available for intake into a human body. The recommended standard is intended to specify the lesser degree of activity distribution.

226.9. The provisions for LSA-III are intended principally to accommodate certain types of radioactive waste consignments with an average estimated specific activity exceeding the 10^{-4} A₂/g limit for LSA-II materials. The higher specific activity limit of 2×10^{-3} A₂/g for LSA-III materials is justified by:

- restricting such materials to solids which are in a non-readily dispersible form, therefore explicitly excluding powders as well as liquids or solutions;
- the need for a leaching test to demonstrate sufficient insolubility of the material when exposed to weather conditions like rainfall (see para. 601.2);
- the higher package standard Industrial Package Type 3 (Type IP-3) under non-exclusive use conditions, which is the same as Type A for solids; in the case of Industrial Package Type 2 (Type IP-2) (para. 524), the lack of the water spray test and the penetration test is compensated for by the leaching test and by operational controls under the exclusive use conditions, respectively.

226.10. The specific activity limit for LSA-II liquids of 10^{-5} A₂/g, which is a factor of 10 more restrictive than for solids, takes into account that the concentration of a liquid may increase during transport.

226.11. A solid compact binding agent, such as concrete, bitumen, etc., which is mixed with the LSA material, is not considered to be an external shielding material. In this case, the binding agent may decrease the surface radiation level and may be taken into account in determining the average specific activity. However, if radioactive material is surrounded by external shielding material, which itself is not radioactive, as illustrated in Fig. 1, this external shielding material is not to be taken into account in determining the specific activity of the LSA material.

226.12. For LSA-II solids, and for LSA-III materials not incorporated into a solid compact binding agent, the Regulations require that the activity be distributed throughout the material. This provision puts no requirement on how the activity is distributed throughout the material, i.e. the activity does not need to be uniformly distributed. It is, however, important to recognize that the concept of limiting the estimated specific activity fails to be meaningful if in a large volume the activity is clearly confined to a small percentage of that volume.

226.13. It is prudent to establish a method by which the significance of the estimated average activity, as determined, can be judged. There are several methods that would be suitable for this particular purpose.

226.14. A simple method for assessing the average activity is to divide the volume occupied by the LSA material into defined portions and then to assess and compare the specific activity of each of these portions. It is suggested that the differences in specific activity between portions of a factor of less than 10 would cause no concern.

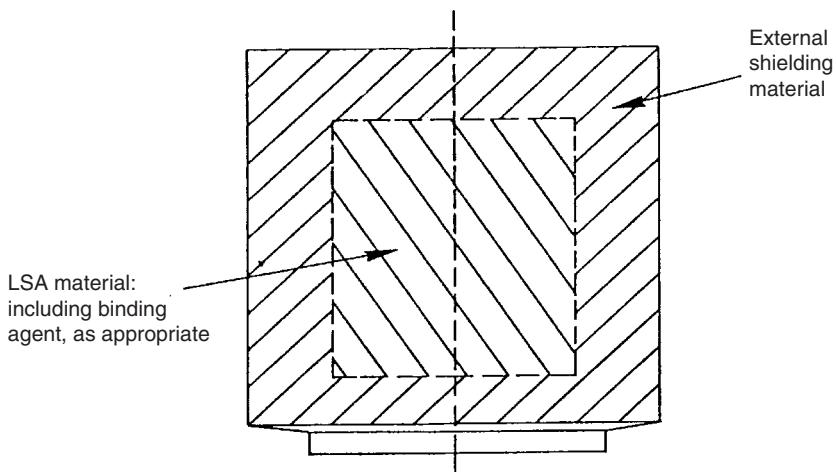

FIG. 1. Low specific activity material surrounded by a cylindrical volume of non-radioactive shielding material.

226.15. Judgement needs to be exercised in selecting the size of the portions to be assessed. The method described in para. 226.14 should not be used for volumes of material of less than 0.2 m^3 . For a volume between 0.2 m^3 and 1.0 m^3 , the volume should be divided into five, and for a volume greater than 1.0 m^3 into ten parts of approximately equivalent size.

226.16. For LSA-III materials consisting of radioactive material within a solid compact binding agent, the requirement is that they be essentially uniformly distributed in this agent. Since the requirement of ‘essentially uniformly distributed’ for LSA-III materials is qualitative, it is necessary to establish methods by which compliance with the requirement can be judged.

226.17. The following method is an example for LSA-III materials which are essentially uniformly distributed in a solid compact binding agent. The method is to divide the LSA material volume including the binding agent into a number of portions. At least ten portions should be selected, subject to the volume of each portion being no greater than 0.1 m^3 . The specific activity of each volume should then be assessed (through measurements, calculations or combinations thereof). It is suggested that specific activity differences between the portions of less than a factor of three would cause no concern. The factor of three in this procedure is more constraining than the suggested factor of ten in para. 226.14 because the ‘essentially uniformly distributed’ requirement is intended to be more constraining than the ‘distributed throughout’ requirement.

226.18. As a consequence of the definition of LSA material, additional requirements are specified for:

- (a) the quantity of LSA material in a single package with respect to the external radiation level of the unshielded material (see para. 521); and
- (b) the total activity of LSA material in any single conveyance (see para. 525 and Table V).

Both requirements can be much more restrictive than the basic requirements for LSA material given in para. 226. This can be seen from the following theoretical example: if it is assumed that a 200 L drum is filled with a solid combustible material with an estimated average specific activity of $2 \times 10^{-3} \text{ A}_2/\text{g}$, it would seem that this material could be transported as LSA-III. However, for example, if the density of the material is 1 g/cm^3 , the total activity in the drum will be $400 \text{ A}_2 [(2 \times 10^{-3} \text{ A}_2/\text{g}) (1 \text{ g/cm}^3) (2 \times 10^5 \text{ cm}^3) = 400 \text{ A}_2]$ and transport as LSA-III would be precluded by the conveyance limit of 10 A_2 by inland waterway and of 100 A_2 by other modes (see Table V of the Regulations). See also para. 525.2.

226.19. Objects which are both activated or otherwise radioactive and contaminated cannot be considered as surface contaminated objects (SCOs) (see para. 241.5). However, such objects may qualify as LSA material since an object having activity throughout and also contamination distributed on its surfaces may be regarded as complying with the requirement that the activity be distributed throughout. For such objects to qualify as LSA material it is necessary to ascertain that the applicable limits on estimated average specific activity are complied with. In assessing the average specific activity, all radioactive material attributed to the object, i.e. both the distributed activity and the activity of the surface contaminations, needs to be included. As appropriate, additional requirements applicable to LSA material need to also be satisfied.

226.20. Compaction of material should not change the classification of the material. To ensure this, the mass of any container compacted with the material should not be taken into account in determining the average specific activity of the compacted material.

226.21. See also Appendix I.

Low toxicity alpha emitters

227.1. The identification of low toxicity alpha emitters is based on the specific activity of the radionuclide (or the radionuclide in its as-shipped state). For a nuclide with a very low specific activity, its intake cannot, because of its bulk, reasonably be expected to give rise to doses approaching the dose limit. The radionuclides U-235, U-238 and Th-232 have specific activities 4 to 8 orders of magnitude lower than Pu-238 or Pu-239 (4×10^3 to 8×10^4 Bq/g as compared with 2×10^9 to 6×10^{11} Bq/g). Although Th-228 and Th-230 have specific activities comparable with those of Pu-238 and Pu-239, they are only allowed as 'low toxicity alpha emitters' when contained in ores and physical and chemical concentrates, which inherently provides for the low activity concentration required.

Maximum normal operating pressure

228.1. The maximum normal operating pressure (MNOP) is the difference between the containment system maximum internal pressure and the mean sea-level atmospheric pressure for the conditions specified below.

228.2. The environmental conditions to be applied to a package in determining the MNOP are the normal environmental conditions specified in paras 653 and 654 or, in the case of air transport, in para. 618. Other conditions to be applied in determining

the MNOP are that the package is assumed to be unattended for a one year period and that it is subject to its maximum internal heat load.

228.3. A one year period exceeds the expected transit time for a package containing radioactive material; besides providing a substantial margin of safety in relation to routine conditions of transport, it also addresses the possibility of loss of a package in transit. The one year period is arbitrary but has been agreed upon as a reasonable upper limit for a package to remain unaccounted for in transit. Since the package is assumed to be unattended for one year, any physical or chemical changes to the packaging or its contents which are transient in nature and could contribute to increasing the pressure in the containment system need to be taken into account. The transient conditions that should be considered include: changes in heat dissipation capability, gas buildup due to radiolysis, corrosion, chemical reactions or release of gas from fuel pins or other encapsulations into the containment system. Some transient conditions may tend to reduce the MNOP, such as the reduction in pressure with time caused by a decrease in internal heat due to radioactive decay of the contents. These conditions may be taken into account if adequately justified.

Overpack

229.1. The carriage of a consignment from one consignor to one consignee may be facilitated by packing various packages or a single package, each of which fully complies with the requirements of the Regulations, into one overpack. Specific design, test or approval requirements for the overpack are not necessary since it is the packaging, not the overpack, which performs the protective function. However, the interaction between the overpack and the packages should be taken into account, especially concerning the thermal behaviour of the packages during routine and normal conditions of transport.

229.2. A rigid enclosure or consolidation of packages for ease of handling in such a way that package labels remain visible for all packages need not be considered as an overpack unless advantage is taken by the consignor of the determination of the TI of the overpack by direct measurement of the radiation level.

Package

230.1. The terms package and packaging are used to distinguish the assembly of components for containing the radioactive material (packaging) from this assembly of components plus the radioactive contents (package).

230.2. A package is the packaging plus its radioactive contents as presented for transport. For design and compliance assurance purposes, this may include any or all structural equipment required for handling or securing the package which is either permanently attached or assembled with the package.

230.3. In order to determine which structural components should be considered part of the package, it is necessary to examine the use and purpose of such equipment with respect to transport. If a package can only be transported with certain structural equipment, it is normal to consider that equipment part of the packaging. This does not mean that a trailer or transport vehicle should be considered part of the package in the case of dedicated transport.

230.4. Because the package may be transported either with or without certain structural equipment, it may be necessary to evaluate both situations in determining packaging suitability and compliance.

230.5. If certain equipment is attached during transport for handling purposes, it also may be necessary to consider its effect in normal and accident conditions of transport. In the case of Type B(U), Type B(M), Type C and packages designed to carry fissile material, the designer must reach agreement with the competent authority for certification.

230.6. A tank, freight container or intermediate bulk container with radioactive contents may be used as one of the types of package under these Regulations provided that it meets the prescribed design, test and any applicable approval requirements for that type of package. Alternatively, a tank, freight container or metal intermediate bulk container with radioactive contents may be used as an industrial package Type IP-2 or Type IP-3 if it meets the Type IP-1 requirements as well as other requirements which are specifically referenced in paras 625–628 of the Regulations.

Packaging

231.1. See paras 230.1 and 230.2.

Radiation level

233.1. One of the limiting quantities in radiological protection against exposure of people is the effective dose (the others being equivalent doses to the lens of the eye and to the skin (e.g. see Section II-8 of Ref. [1]). As this is not a directly measurable quantity, operational quantities had to be created which are measurable. These quantities are ‘ambient dose equivalent’ for strongly penetrating radiation and

‘directional dose equivalent’ for weakly penetrating radiation. The radiation level should be taken as the value of the operational quantity ‘ambient dose equivalent’ or ‘directional dose equivalent’, as appropriate.

233.2. In some cases consideration should be given to the possibility of an increase in radiation as a result of the buildup of daughter nuclides during transport. In such cases a correction should be applied to represent the highest radiation level envisaged during the transport.

233.3. In mixed gamma and neutron fields it may be necessary to make separate measurements. It should be ensured that the monitoring instrument being used is appropriate for the energy being emitted by the radionuclide and that the calibration of the instrument is still valid. In performing both the initial measurement and any check measurement, the uncertainties in calibration have to be taken into account.

233.4. For neutron dosimeters there is very often a significant dependence of the reading on the neutron energy. The spectral distribution of the neutrons used for calibration and the spectral distribution of the neutrons to be measured may affect the accuracy of dose determination considerably. If the energy dependence of the instrument reading and the spectral distribution of the neutrons to be measured are known, a corresponding correction factor may be used.

233.5. The Regulations require that, at the surfaces of packages and overpacks, specific radiation levels shall not be exceeded. In most cases a measurement made with a hand instrument held against the surface of the package indicates the reading at some distance away because of the physical size of the detector volume. The instrument used for the measurement of the radiation level should, where practicable, be small in relation to the dimensions of the package or overpack. Instruments which are large relative to the physical size of the package or overpack should not be used because they might underestimate the radiation level. Where the distance from the source to the instrument is large in relation to the size of the detector volume (e.g. a factor of five), the effect is negligible and can be ignored; otherwise the values in Table I should be used to correct the measurement. For radiographic devices where the source to surface distance is generally kept to a minimum, the effect is usually not negligible, and an allowance should be made for the size of the detector volume.

233.6. When monitoring finned flasks or other transport packages, care should be taken where narrow radiation beams may be encountered. A dose rate meter, with a detector area much larger than the cross-sectional area of the beam to be measured, will yield a proportionally reduced reading of dose rate because of averaging over the much larger detector area. An appropriate instrument should be chosen for the work.

Radioactive material

236.1. In previous editions of the Regulations, a single exemption value of 70 Bq/g was used to define radioactive material for transport purposes. Following publication of the BSS [1], it was recognized that this value had no radiological basis. The radiological protection criteria defined in the BSS were therefore used to establish radionuclide specific exemption values for transport purposes (see para. 401.3).

Shipment

237.1. In the context of the transport of radioactive material, the term ‘destination’ means the end point of a journey at which the package is, or is likely to be, opened, except during customs operations as described in para. 581.

Special arrangement

238.1. The use of the ‘special arrangement’ should not be taken lightly. This type of shipment is intended for those situations where the normal requirements of the Regulations cannot be met. For example, the disposal of old equipment containing radioactive material where there is no reasonable way to ship the radioactive material in an approved package. The hazard associated with repackaging and handling the radioactive material could outweigh the advantage of using an approved package,

TABLE I. CORRECTION FACTORS FOR PACKAGE AND DETECTOR SIZES

Distance between detector centre and package surface (cm)	Half linear dimension of package (cm)	Correction factor ^a
1	>10	1.0
2	10–20	1.4
	>20	1.0
5	10–20	2.3
	20–50	1.6
	>50	1.0
10	10–20	4.0
	20–50	2.3
	50–100	1.4
	>100	1.0

^a The reading should be multiplied by the correction factor to obtain the actual radiation level at the surface of the package.

assuming a suitable package is available. The special arrangement provisions should compensate for not meeting all the normal requirements of the Regulations by providing an equivalent level of safety. In keeping with the underlying philosophy of the transport regulations, reliance on administrative measures should be minimized in establishing the compensating measures.

Special form radioactive material

239.1. The Regulations are based on the premise that the potential hazard associated with the transport of non-fissile radioactive material depends on four important parameters:

- the dose per unit intake (by ingestion or inhalation) of the radionuclide;
- the total activity contained within the package;
- the physical form of the radionuclide;
- the potential external radiation levels.

239.2. The Regulations acknowledge that radioactive material in an indispersible form or sealed in a strong metallic capsule presents a minimal contamination hazard, although the direct radiation hazard still exists. Material protected in this way from the risk of dispersion during accident conditions is designated as ‘special form radioactive material’. Radioactive material which itself is dispersible may be adsorbed, absorbed or bonded to an inert solid in such a manner that it acts as an indispersible solid, e.g. metal foils. See paras 603.1–603.4, 604.1 and 604.2.

239.3. Unless the radioactive contents of a package are in special form, the quantity of radioactive material that can be carried in an excepted or Type A package will be limited to A_2 or multiples thereof. For example, a Type A package is limited to A_2 and the contents of excepted packages are limited to values ranging from A_2 to as low as $10^{-4} A_2$, or $10^{-5} A_2$ if transported by post, depending upon whether the material is solid, liquid or gas and whether or not it is incorporated into an instrument or article. However, if the material is in special form, the package limits change from A_2 to A_1 or appropriate multiples thereof. Depending on the radionuclide(s) involved, the A_1 values differ from the A_2 values by factors ranging from 1 to 10 000 (see Table I of the Regulations). The capability to ship an increased quantity in a package if it is in special form applies only to Type A and excepted packages.

Specific activity

240.1. The definition of specific activity in practice covers two different situations. The first, the definition of the specific activity of a radionuclide, is similar to the

ICRU definition of specific activity of an element. The second, the definition of the specific activity of a material for the Regulations is more precisely a mass activity concentration. Thus, the definition of specific activity is given for both cases and depends upon its specific application in the requirements of the Regulations. The term ‘activity concentration’ is also used in some paragraphs of the Regulations (e.g. see para. 401 and the associated Table I of the Regulations).

240.2. The half-life and the specific activity for each individual radionuclide given in Table I of the Regulations are shown in Table II.1 of Appendix II. These values of specific activity were calculated using the following equation:

$$\begin{aligned} \text{Specific activity (Bq/g)} &= \frac{(\text{Avogadro's number}) \times \lambda}{(\text{atomic mass})} \\ &= \frac{4.18 \times 10^{23}}{A \times T_{1/2}} \end{aligned}$$

where

A is the atomic mass of the radionuclide,

$T_{1/2}$ is the half-life (s) of the radionuclide, and

λ is the decay constant (s^{-1}) of the radionuclide = $\ln 2/T_{1/2}$.

240.3. The specific activity of any radionuclide not listed in Table II.1 of Appendix II can be calculated using the equation shown in para. 240.2.

240.4. The specific activity of uranium, for various levels of enrichment, is shown in Table II.3 of Appendix II.

240.5. In determining the specific activity of a material in which radionuclides are distributed, the entire mass of that material or a subset thereof, i.e. the mass of radionuclides and the mass of any other material, needs to be included in the mass component. The different interpretations of specific activity in the definition of LSA material (para. 226) and in Table II.1 should be noted.

Surface contaminated object

241.1. A differentiation is made between two categories of surface contaminated objects (SCOs) in terms of their contamination level, and this defines the type of packaging to be used to transport these objects. The Regulations provide adequate flexibility for the unpackaged shipment of SCO-I objects or their shipment in an

Industrial package (Type IP-1). The higher level of non-fixed contamination permitted on objects classified as SCO-II requires the higher standard of containment afforded by Industrial package Type IP-2.

241.2. The SCO-I model used as justification for the limits for fixed and non-fixed contamination is based on the following scenario. Objects in the category of surface contaminated objects include those parts of nuclear reactors or other fuel cycle equipment that have come into contact with primary or secondary coolant or process waste, resulting in contamination of their surface with mixed fission products. On the basis of the allowable contamination levels for beta and gamma emitters, an object with a surface area of 10 m^2 could have fixed contamination up to 4 GBq and non-fixed contamination up to 0.4 MBq. During routine transport this object can be shipped unpackaged under exclusive use, but it is necessary to secure the object (para. 523(a)) to ensure that there is no release of radioactive material from the conveyance. The SCO-I object and other cargo is assumed to move in an accident such that 20% of the surface of the SCO-I object is scraped and 20% of the fixed contamination from the scraped surface is freed. In addition, all of the non-fixed contamination is considered to be released. The total activity of the release would thus be 160 MBq for fixed contamination and 0.4 MBq for non-fixed contamination. Using an A_2 value of 0.02 TBq for mixed beta and gamma emitting fission products, the activity of the release equates to $8 \times 10^{-3} A_2$. It is considered that such an accident would only occur outside so that, consistent with the basic assumption of the Q system developed for Type A packages (see Appendix I), an intake of 10^{-4} of the scraped radionuclides for a person in the vicinity of the accident is appropriate. This would result in a total intake of $0.8 \times 10^{-6} A_2$. Hence this provides a level of safety equivalent to that of Type A packages.

241.3. The model for an SCO-II object is similar to that for an SCO-I object, although there may be up to 20 times as much fixed contamination and 100 times as much non-fixed contamination. However, an Industrial package (IP-2) is required for the transport of SCO-II objects. The presence of this package will lead to a release fraction in an accident which approaches that for a Type A package. Using a release fraction of 10^{-2} results in a total release of beta and gamma emitting radionuclides of 32 MBq of fixed contamination and 8 MBq of non-fixed contamination, which equates to $2 \times 10^{-3} A_2$. Applying the same intake factor as in the previous paragraph leads to an intake of $0.2 \times 10^{-6} A_2$, thereby providing a level of safety equivalent to that of Type A packages.

241.4. If the total activity of an SCO is so low that the activity limits for excepted packages according to para. 408 are met, it can be transported as an excepted package, provided that all the applicable requirements and controls for transport of excepted packages (paras 515–519) are complied with.

241.5. Surface contaminated objects are by definition objects which are themselves not radioactive but have radioactive materials distributed on their surfaces. The implication of this definition is that objects that are radioactive themselves (e.g. activated objects) and are also contaminated cannot be classified as SCOs. Such objects may, however, be regarded as LSA material insofar as the requirements specified in the LSA definition are complied with. See also para. 226.19.

241.6. Examples of inaccessible surfaces are:

- inner surfaces of pipes the ends of which can be securely closed by simple methods;
- inner surfaces of maintenance equipment for nuclear facilities which are suitably blanked off or formally closed;
- glove boxes with access ports blanked off.

241.7. Measurement techniques for fixed and non-fixed contamination of packages and conveyances are given in paras 508.2 and 508.7–508.12. These techniques are applicable to SCOs. However, to apply these techniques properly, a consignor needs to know the composition of the contamination.

Tank

242.1. The lower capacity limit of 450 L (1000 L in the case of gases) is included to achieve harmonization with the United Nations Recommendations [6].

242.2. Paragraph 242 includes solid contents in tanks where such contents are placed in the tank in liquid or gaseous form and subsequently solidified prior to transport (for example, uranium hexafluoride, UF₆).

Transport index

243.1. The TI performs many functions in the Regulations, including providing the basis for the carrier to segregate radioactive materials from persons, undeveloped film and other radioactive material consignments and to limit the level of radiation exposure to members of the public and transport workers during transport and in-transit storage.

243.2. In the 1996 edition of the Regulations the TI no longer makes any contribution to the criticality safety control of packages containing fissile material. Control for criticality safety is now provided by a separate criticality safety index (CSI) (see paras 218.1 and 218.2). Although the previous approach of a single control value for

radiological protection and criticality safety provided for simple operational application, the current use of a separate TI and CSI removes significant limitations on segregation in the transport and storage in transit of packages not containing fissile material. The reason for retaining the designation of TI is that the vast majority of radioactive consignments are not carrying fissile material and, therefore, a new name for the 'radioactive only' TI could have created confusion because of the need to introduce and explain two new names. Care should be taken not to confuse the use of the TI value and to consider the CSI value as the only control for accumulation of packages for criticality safety.

243.3. See paras 526.1–526.4.

Unirradiated thorium

244.1. The term 'unirradiated thorium' in the definition of low specific activity material is intended to exclude any thorium which has been irradiated in a nuclear reactor so as to transform some of the Th-232 into U-233, a fissile material. The definition could have prohibited the presence of any U-233, but naturally occurring thorium may contain trace amounts of U-233. The limit of 10^{-7} g of U-233 per gram of Th-232 is intended to clearly prohibit any irradiated thorium while recognizing the presence of trace amounts of U-233 in natural thorium.

Unirradiated uranium

245.1. The term 'unirradiated uranium' is intended to exclude any uranium which has been irradiated in a nuclear reactor so as to transform some of the U-238 into Pu-239 and some of the U-235 into fission products. The definition could have prohibited the presence of any plutonium or fission products, but naturally occurring uranium may contain trace amounts of plutonium and fission products. In the 1985 edition of the Regulations, the limits of 10^{-6} g of plutonium per gram of U-235 and 9 MBq of fission products per gram of U-235 were intended to clearly prohibit any irradiated uranium while recognizing the presence of trace amounts of plutonium and fission products in natural uranium.

245.2. The presence of U-236 is a more satisfactory indication of exposure to a neutron flux. 5×10^{-3} g of U-236 per gram of U-235 has been chosen as representing the consensus view of ASTM Committee C-26 in specification C-996 for enriched commercial grade uranium. This value is incorporated into the 1996 edition of the Regulations and recognizes the possibility for trace contamination by irradiated uranium but ensures that the material may still be treated as unirradiated. This specification represents the composition with the maximum value for uranium radionuclides

for which the A_2 value for uranium hexafluoride can be demonstrated to be unlimited. The difference in A_2 for uranium dioxide is considered to be insignificant [7].

REFERENCES TO SECTION II

- [1] FOOD AND AGRICULTURE ORGANIZATION OF THE UNITED NATIONS, INTERNATIONAL ATOMIC ENERGY AGENCY, INTERNATIONAL LABOUR ORGANISATION, OECD NUCLEAR ENERGY AGENCY, PAN AMERICAN HEALTH ORGANIZATION, WORLD HEALTH ORGANIZATION, International Basic Safety Standards for Protection against Ionizing Radiation and for the Safety of Radiation Sources, Safety Series No. 115, IAEA, Vienna (1996).
- [2] AMERICAN NUCLEAR SOCIETY, American National Standard for Nuclear Criticality Control of Special Actinide Elements, ANSI/ANS-8.15-1981 (reaffirmed 1987), ANS, New York (1981).
- [3] INTERNATIONAL ORGANIZATION FOR STANDARDIZATION, Series 1 Freight Containers — Specifications and Testing — Part 1: General Cargo Containers, ISO 1496:1–1990(E), ISO, Geneva (1990).
- [4] INTERNATIONAL MARITIME ORGANIZATION, International Convention for Safe Containers, IMO, London (1984).
- [5] INTERNATIONAL MARITIME ORGANIZATION, International Maritime Dangerous Goods (IMDG) Code, 2000 edition including amendment 30–00, IMO, London (2001).
- [6] UNITED NATIONS, Recommendations on the Transport of Dangerous Goods, Ninth Revised Edition (ST/SG/AC.10/1/Rev.9), UN, New York and Geneva (1995).
- [7] INTERNATIONAL ATOMIC ENERGY AGENCY, Interim Guidance for the Safe Transport of Reprocessed Uranium, IAEA-TECDOC-750, IAEA, Vienna (1994).

Section III

GENERAL PROVISIONS

RADIATION PROTECTION²

301.1. The objectives of the Radiation Protection Programme (RPP) for the transport of radioactive material are:

- to provide for adequate consideration of radiation protection measures in transport;
- to ensure that the system of radiological protection is adequately applied;
- to enhance a safety culture in the transport of radioactive material; and
- to provide practical measures to meet these objectives.

The RPP should include, to the extent appropriate, the following elements:

- (a) scope of the programme (see paras 301.2–301.4);
- (b) roles and responsibilities for the implementation of the programme (see para. 301.5);
- (c) dose assessment (see para. 305);
- (d) surface contamination assessment (see paras 508, 513 and 514);
- (e) dose limits, dose constraints and optimization (see para. 302);
- (f) segregation distances (see paras 306–307);
- (g) emergency response (see paras 308–309);
- (h) training (see para. 303); and
- (i) quality assurance (see para. 310).

301.2. The scope of the RPP should include all the aspects of transport as defined in para. 106 of the Regulations. However, it is recognized that in some cases certain aspects of the RPP may be covered in RPPs at the consigning, receiving or storage-in-transit sites. Since the magnitude and extent of measures to be employed in the RPPs will depend on the magnitude and likelihood of exposures, a graded approach should be followed.

² After the text of this publication had been prepared, the IAEA issued Safety Standards Series No. RS-G-1.1, Occupational Radiation Protection, IAEA, Vienna (1999). This Safety Guide may provide additional guidance on the development and implementation of radiation protection programmes and the monitoring and assessing of radiation doses.

301.3. Both the package type and the package category need to be considered. For routine transport the external radiation is important and the package category provides a classification for this; under accident conditions, however, it is the package type (Excepted, Industrial, Type A, Type B or Type C) that is important. Excepted, Industrial and Type A packages are not required to withstand accidents. For those aspects of the RPP related to accident conditions of transport, the possibility of leakage from these package types as the result of transport or handling accidents will need to be considered. In contrast, Type B and Type C packages can be expected to withstand all but the most severe accidents.

301.4. The external radiation levels from excepted packages and Category I-WHITE label packages are sufficiently low so as to be safe to handle without restriction, and a dose assessment is therefore unnecessary. Consideration of radiation protection requirements can be limited to keeping handling times as low as reasonably achievable, and segregation can be met by avoiding prolonged direct contact of packages with persons and other goods during transport. A dose assessment will, however, be needed for Category II- and III-YELLOW label packages, and segregation, dose limits, constraints and optimization will need to be considered in its light.

301.5. The RPP will best be established through the co-operative effort of consignors, carriers and consignees engaged in the transport of radioactive material. Consignors and consignees should normally have an appropriate RPP as part of fixed facility operations. The role and responsibilities of the different parties and individuals involved in the implementation of the RPP should be clearly identified and described. Overlapping of responsibilities should be avoided. Depending on the magnitude and likelihood of radiation exposures, the overall responsibility for establishment and implementation of the RPP may be assigned to a health physics or safety officer recognized through certification by appropriate boards or societies, or other appropriate means (e.g. by the relevant competent authorities), as a 'qualified expert' [1].

302.1. Optimization of protection and safety requires that both normal and potential exposures be taken into account. Normal exposures are exposures that are expected to be received under routine and normal transport conditions as defined in para. 106 of the Regulations. Potential exposures are exposures that are not expected to be delivered with certainty but that may result from an accident or owing to an event or sequence of events of a probabilistic nature, including equipment failures and operating errors. In the case of normal exposures, optimization requires that the expected magnitude of individual doses and the number of people exposed be taken into account; in addition, in the case of potential exposures, the likelihood of the occurrence of accidents or events or sequences of events is also taken into account. Optimization should be documented in the RPPs. See also Ref. [2].

302.2. The Basic Safety Standards [1] define radiological protection requirements for practices (activities that increase the overall exposure to radiation) and for intervention (activities that decrease the overall exposure by influencing the existing causes of exposure). The system of radiological protection for practices as set out in the Basic Safety Standards (Section 2, Principal Requirements) is summarized as follows:

- No practice is to be adopted unless it produces a positive net benefit (justification of a practice).
- All exposures are to be kept as low as reasonably achievable, economic and social factors being taken into account (optimization of protection).
- Total individual exposure is to be subject to dose limits or, in the case of potential exposures, to the control of risk (individual dose and risk limits).

302.3. In practical radiological protection there has in the past existed, and there continues to exist, a need to establish standards associated with quantities other than the basic dose limits. Standards of this type are normally known as secondary or derived limits. When such limits are related to the primary limits of dose by a defined model, they are referred to as derived limits. Derived limits have been used in the Regulations.

302.4. Examples of derived limits in the Regulations include the maximum activity limits A_1 and A_2 , maximum levels for non-fixed contamination, radiation levels at the surfaces of packages and in their proximity, and segregation distances associated with the transport index. The Regulations require assessment and measurement to ensure that standards are being complied with.

302.5. It should be a task of the competent authority to ensure that all transport activities are conducted under a general framework of optimization of protection and safety.

303.1. The provision of information and training is an integral part of any system of radiological protection. The level of instruction provided should be appropriate to the nature and type of work undertaken. Workers involved in the transport of radioactive material require training concerning the radiological risks in their work and how they can minimize these risks in all circumstances.

303.2. Training should relate to specific jobs and duties, to specific protective measures to be undertaken in the event of an accident or to the use of specific equipment. It should include general information relating to the nature of radiological risk, knowledge of the nature of ionizing radiation, the effects of ionizing radiation and its

measurement, as appropriate. Training should be seen as a continuous commitment throughout employment and involves initial training and refresher courses at appropriate intervals. The effectiveness of the training should be periodically checked.

303.3. Information on specific training requirements has been published [3, 4].

304.1. The competent authority assessments may be used to evaluate the effectiveness of the Regulations, including those for RPPs, and may be part of the compliance assurance activities detailed in Ref. [5] (see also paras 311.1–311.8). Of particular importance is the assessment of whether there is effective optimization of radiation protection and safety. This may also help in achieving and maintaining public confidence.

304.2. In order to comply with para. 304 of the Regulations, information on the radiation doses to workers and to members of the public should be collected and reviewed as appropriate. Reviews should be made if circumstances warrant, e.g. if significant changes in transport patterns occur or when a new technology related to radioactive material is introduced. The collection of relevant information may be achieved through a combination of radiation measurements and assessments. Reviews of accident conditions of transport are necessary in addition to those of routine and normal conditions.

305.1. The Basic Safety Standards [1] set a limit on effective dose for the members of the public of 1 mSv/a, and for workers of 20 mSv, averaged over five consecutive years and not exceeding 50 mSv in a single year. Dose limits in special circumstances, dose limits in terms of equivalent dose for the lens of the eye, extremities (hand and feet) and skin, and dose limits for apprentices and pregnant women are also set out in the Basic Safety Standards and should be considered in the context of the requirements of para. 305. These limits apply to exposures attributable to all practices, with the exception of medical exposures and of exposures from certain natural sources.

305.2. Three categories for monitoring and assessing radiation doses are shown in para. 305. The first category establishes a dose range where little action needs to be taken for evaluating and controlling doses. The upper value of this range is 1 mSv in a year, which was chosen to coincide with the dose limit for a member of the public. The second category has an upper value of 6 mSv/a, which is 3/10 of the limit on effective dose for workers (averaged over 5 years). This level represents a reasonable dividing line between conditions where dose limits are unlikely to be approached and conditions where dose limits could be approached. The third category is for any situation where the occupational exposure is expected to exceed the 6 mSv/a upper value in the second category.

305.3. Many transport workers will be in the first category, and no specific measures concerning monitoring or control of exposure are required. In the second category, a dose assessment programme will be necessary. This may be based upon either individual monitoring or monitoring of the workplace. In the latter case, workplace monitoring may often be achieved by radiation level measurements in occupied areas at the start and end of a particular stage of a journey. In some cases, however, air monitoring, surface contamination checks and individual monitoring may also be required. In the third category, individual monitoring is mandatory. In most cases this will be accomplished by the use of personal dosimetry such as film badges, thermoluminescent dosimeters and, where necessary, neutron dosimeters (see also footnote 2).

305.4. Some studies of particular operations have shown a correlation between dose received by workers and the number of transport indexes handled [6]. It is unlikely that carriers handling less than 300 TI per year will exceed doses of 1 mSv/a and such carriers would not therefore require detailed monitoring, dose assessment or individual records.

305.5. Given that relatively high radiation levels are permitted during carriage under exclusive use, additional care should be taken to ensure that the requirements of para. 305 are met, since it would be relatively easy to exceed the 1 mSv level, and consequently specific measures regarding monitoring or control of exposures should be taken. In the assessment of the correct exposure category, exposures received during the carriage phase of transport should be considered together with those received elsewhere, particularly during loading and unloading.

306.1. The dose level of 5 mSv/a for occupationally exposed workers and of 1 mSv/a to the critical group [1] for members of the public are specifically defined values to be used for the purposes of calculating segregation distances or dose rates for regularly occupied areas. The distances and dose rates are, for convenience, often presented in segregation tables. The dose values given in para. 306 are for segregation distance or calculation purposes only and are required to be used together with hypothetical but realistic parameters in order to obtain appropriate segregation distances. Using the given values provides reasonable assurance that actual doses from the transport of radioactive materials will be well below the appropriate average annual dose limits.

306.2. These values together with simple, robust modelling have been used for a number of years to derive segregation tables for different modes of transport. Assessments of radiation exposures arising indicate that continued use of these values is acceptable. In particular, surveys of exposure occurring in air and sea

transport [7, 8] have shown that segregation distances derived from them have resulted in doses to the public below the relevant annual dose limits and that doses to workers not involved in direct handling are also less than 1 mSv/a. The use of segregation distances does not in itself remove the requirement for undertaking the evaluation required in para. 305 of the Regulations.

306.3. The Regulations state the requirements for radiation protection which are to be fulfilled in the determination of segregation distances (i.e. minimum distances between radioactive material packages and regularly occupied areas of a conveyance) and of dose rates in regularly occupied areas. For practical purposes it may be helpful to provide this information in the form of segregation tables.

307.1. Although not a radiation protection issue, an evaluation of the effect of radiation on fast X ray films in 1947 [9] determined that they may show slight fogging after development when exposed to doses exceeding 0.15 mSv of gamma radiation. This could interfere with the proper use of the film and provide incorrect diagnostic interpretation. Other types of film are also susceptible to fogging although the doses required are much higher. Since it would be impracticable to introduce segregation procedures which vary with the type of film, the provisions of the Regulations are designed to restrict the exposure of undeveloped films of all kinds to a level of not more than 0.1 mSv during any journey from consignor to consignee.

307.2. The different time durations involved for sea transport (in terms of days or weeks) and air or land transport (in terms of hours or days) mean that different tables of segregation distances are used, so that the total film exposure during transit is the same for each mode. More than one mode of transport and more than one shipment may be involved in the distribution and ultimate use of photographic film. Thus, when segregation distance tables are being established for a specific transport mode, only a fraction of the limit prescribed in para. 307 should be committed to that mode.

307.3. In road transport a driver may ensure sufficient segregation from photographic film carried in other vehicles by leaving a clear space of at least 2 m all around the vehicle when parking.

EMERGENCY RESPONSE

308.1. The requirements established in the Regulations, when complied with by the package designer, consignor, carrier and consignee, ensure a high level of safety for the transport of radioactive material. However, accidents involving such packages may happen. Paragraph 308 of the Regulations recognizes that advance planning and

preparation are required to provide a sufficient and safe response to such accidents. The response, in most cases, will be similar to the response to radiation accidents at fixed site facilities. Thus, it is required that relevant national or international organizations establish emergency procedures, and that these procedures be followed in the event of a transport accident involving radioactive material.

308.2. Further guidance can be found in Ref. [10].

309.1. The radioactive hazard may not be the only potential hazard posed by the contents of a package of radioactive material. Other hazards may exist, including pyrophoricity, corrosivity or oxidizing properties; or, if released, the contents may react with the environment (air, water, etc.), in turn producing hazardous substances. It is this latter phenomenon which para. 309 of the Regulations addresses so as to ensure proper safety from chemical (i.e. non-radioactive) hazards, and specific attention is drawn to uranium hexafluoride (UF_6) because of its propensity to react, under certain conditions, both with moisture in the air and with water to form hydrogen fluoride and uranyl fluoride (HF and UO_2F_2).

309.2. In the event that the containment system of a package is damaged in an accident, air and/or water may reach and, in some cases, chemically react with the contents. For some radioactive materials, these chemical reactions may produce caustic, acidic, toxic or poisonous substances which could be hazardous to people and the environment. Consideration should be given to this problem in the design of the package and in emergency response planning procedures to reduce the consequences of such reactions. In doing so, the quantities of materials involved, the potential reaction kinetics, the ameliorating effects of reaction products (self-extinguishing, self-plugging, insolubility, etc.), and the potential for concentration or dilution within the environment should all be considered. Such considerations may lead to restrictions on the package design or its use which go beyond considerations of the radioactive nature of the contents.

QUALITY ASSURANCE

310.1. Quality assurance is essentially a systematic and documented method to ensure that the required conditions or levels of safety are consistently achieved. Any systematic evaluation and documentation of performance judged against an appropriate standard is a form of quality assurance. A disciplined approach to all activities affecting quality, including, where appropriate, specification and verification of satisfactory performance and/or implementation of appropriate corrective actions, will contribute to transport safety and provide evidence that the required quality has been achieved.

310.2. The Regulations do not prescribe detailed quality assurance programmes because of the wide diversity of operational needs and the somewhat differing requirements of the competent authorities of each Member State. A framework upon which all quality assurance programmes may be based is provided in Appendix IV. The degree of detail in the quality assurance programme will depend on the phase and type of transport operation, adopting a graded approach consistent with para. 104 of the Regulations.

310.3. The development and application of quality assurance programmes, as required by the Regulations, should be carried out in a timely manner, before transport operations commence. Where appropriate, the competent authority will ensure that such quality assurance programmes are implemented, as part of the timely adoption of the Regulations.

310.4. Further guidance is given in Ref. [11].

COMPLIANCE ASSURANCE

311.1. The adoption of transport safety regulations, based on the Regulations, should be carried out within an appropriate time frame in Member States and by all relevant international organizations. Emphasis is placed on the timely implementation of systematic compliance assurance programmes to complement the adoption of the Regulations.

311.2. As used in the Regulations, the term ‘compliance assurance’ has a broad meaning which includes all of the measures applied by a competent authority that are intended to ensure that the provisions of the Regulations are complied with in practice. Compliance means, for example, that:

- (a) Appropriate and sound packages are used;
- (b) The activity of radioactive material in each package does not exceed the regulatory activity limit for that material and that package type;
- (c) The radiation levels external to, and the contamination levels on, surfaces of packages do not exceed the appropriate limits;
- (d) Packages are properly marked and labelled and transport documents are complete;
- (e) The number of packages containing radioactive material in a conveyance is within the regulatory limits;
- (f) Packages of radioactive material are stowed in conveyances and are stored at a safe distance from persons and photosensitive materials;

- (g) Only those stowage and lifting devices which have been tested are used in loading, conveying and unloading packages of radioactive material (see para. 564);
- (h) Packages of radioactive material are properly secured for transport;
- (i) Only trained personnel handle radioactive material packages during transport operations, including drivers of vehicles who may also load or unload the packages.

311.3. The principal objectives of a systematic programme of compliance assurance are:

- to provide independent verification of regulatory compliance by the users of the Regulations; and
- to provide feedback to the regulatory process as a basis for improvements to the Regulations and the compliance assurance programme.

311.4. An effective compliance assurance programme should, as a minimum, include measures related to:

- review and assessment, including the issuance of approval certificates; and
- inspection and enforcement.

311.5. A compliance assurance programme can only be implemented if its scope and objectives are conveyed to all parties involved in the transport of radioactive materials, i.e. designers, manufacturers, consignors and carriers. Therefore, compliance assurance programmes should include provisions for information dissemination. This should inform users about the way the competent authority expects them to comply with the Regulations and about new developments in the regulatory field. All parties involved should use trained staff.

311.6. In order to ensure the adequacy of special form radioactive material (see para. 239 of the Regulations) and certain package designs, the competent authority is required to assess these designs (see para. 802 of the Regulations). In this way the competent authority can ensure that the designs meet the regulatory requirements and that the requirements are applied in a consistent manner by different users. When required by the Regulations, shipments are also subject to review and approval in order to ensure that adequate safety arrangements are made for transport operations.

311.7. The competent authority should perform audits and inspections as part of its compliance assurance programme in order to confirm that the users are meeting all applicable requirements of the Regulations and are applying their quality assurance

programmes. Inspections are also necessary to identify instances of non-compliance which may necessitate either corrective action by the user or enforcement action by the competent authority. The primary purpose of an enforcement programme is not to carry out punitive action but to foster compliance with the Regulations.

311.8. Since the Regulations include requirements for emergency provisions for the transport of radioactive materials (see para. 308 of the Regulations), a compliance assurance programme should include activities pertaining to emergency planning and preparedness and to emergency response when needed. These activities should be incorporated into the appropriate national emergency plans. The appropriate competent authority should also ensure that consignors and carriers have adequate emergency plans.

311.9. Further guidance is given in Ref. [5].

SPECIAL ARRANGEMENT

312.1. The intent of para. 312 of the Regulations is consistent with similar provisions in the earlier editions of the Regulations. Indeed, the Regulations have, from the earliest edition in 1961, permitted the transport of consignments not satisfying all the specifically applicable requirements, but this can only be done under special arrangement. Special arrangement is based on the requirement that the overall level of safety resulting from additional operational control must be shown to be at least equivalent to that which would be provided had all applicable provisions been met (see para. 104.1). Since the normally applicable regulatory requirements are not being satisfied, each special arrangement must be specifically approved by all competent authorities involved (i.e. multilateral approval is required).

312.2. The concept of special arrangement is intended to give flexibility to consignors to propose alternative safety measures effectively equivalent to those prescribed in the Regulations. This makes possible both the development of new controls and techniques to satisfy the existing and changing needs of industry in a longer term sense and the use of special operational measures for particular consignments where there may be only a short term interest. Indeed, the role of special arrangement as a possible means of introducing and testing new safety techniques which can later be assimilated into specific regulatory provisions is also vital as regards the further development of the Regulations.

312.3. It is recognized that unplanned situations may arise during transport, such as a package suffering minor damage or in some way not meeting all the relevant

requirements of the Regulations, which will require action to be taken. When there is no immediate health, safety or physical security concern, a special arrangement may be appropriate. Special arrangements should not be required to deal with occurrences of non-compliance which may require immediate transport to bring the non-compliant situation under appropriate health and safety controls. It is considered that the emergency response procedures of Ref. [10] and the compliance assurance programmes of Ref. [5] provide better approaches in most cases for unplanned events of these types.

312.4. Approval under special arrangement can be sought in respect of shipments where variations from standard package design features result in the need to apply compensatory safety measures in the form of more stringent operational controls. Details of possible additional controls which can be used in practice for this purpose are included in para. 825.1. Information supplied to support equivalent safety arguments may comprise quantitative data, where available, and may range from considered judgement based on relevant experience to probabilistic risk analysis.

REFERENCES TO SECTION III

- [1] FOOD AND AGRICULTURE ORGANIZATION OF THE UNITED NATIONS, INTERNATIONAL ATOMIC ENERGY AGENCY, INTERNATIONAL LABOUR ORGANISATION, OECD NUCLEAR ENERGY AGENCY, PAN AMERICAN HEALTH ORGANIZATION, WORLD HEALTH ORGANIZATION, International Basic Safety Standards for Protection against Ionizing Radiation and for the Safety of Radiation Sources, Safety Series No. 115, IAEA, Vienna (1996).
- [2] INTERNATIONAL ATOMIC ENERGY AGENCY, Discussion of and Guidance on the Optimization of Radiation Protection in the Transport of Radioactive Material, IAEA-TECDOC-374, IAEA, Vienna (1986).
- [3] UNITED NATIONS ECONOMIC COMMISSION FOR EUROPE, INLAND TRANSPORT COMMITTEE, European Agreement Concerning the International Carriage of Dangerous Goods by Road (ADR), 1997 edition, marginals 10315, 71315 and Appendix B4, UNECE, Geneva (1997).
- [4] RIDDER, K., "The training of dangerous goods drivers in Europe", PATRAM 95 (Proc. Symp. Las Vegas, 1995), USDOE, Washington, DC (1995).
- [5] INTERNATIONAL ATOMIC ENERGY AGENCY, Compliance Assurance for the Safe Transport of Radioactive Material, Safety Series No. 112, IAEA, Vienna (1994).
- [6] WILSON, C.K., SHAW, K.B., GELDER, R., "Towards the implementation of ALARA in Transport", PATRAM 92 (Proc. Symp. Yokohama City, 1992), Science & Technology Agency, Tokyo (1992).
- [7] WILSON, C.K., The air transport of radioactive materials, Radiat. Prot. Dosim. **48** 1 (1993) 129-133.

- [8] WILSON, C.K., SHAW, K.B., GELDER, R., “Radiation doses arising from the sea transport of radioactive materials”, PATRAM 89 (Proc. Symp. Washington, DC, 1989), Oak Ridge National Laboratory, Oak Ridge, TN (1989).
- [9] FAIRBAIRN, A., The development of the IAEA Regulations for the Safe Transport of Radioactive Materials, At. Energ. Rev. **11** 4 (1973) 843.
- [10] INTERNATIONAL ATOMIC ENERGY AGENCY, Emergency Response Planning and Preparedness for Transport Accidents Involving Radioactive Material, Safety Series No. 87, IAEA, Vienna (1988).
- [11] INTERNATIONAL ATOMIC ENERGY AGENCY, Quality Assurance for the Safe Transport of Radioactive Material, Safety Series No. 113, IAEA, Vienna (1994).

Section IV

ACTIVITY LIMITS AND MATERIAL RESTRICTIONS

BASIC RADIONUCLIDE VALUES

401.1. The activity limitation on the contents of Type A packages (A_1 for special form material and A_2 for material not in special form) for any radionuclide or combination of radionuclides is derived on the basis of the radiological consequences which are deemed to be acceptable, within the principles of radiological protection, following failure of the package after an accident. The method of deriving A_1 and A_2 values is given in Appendix I.

401.2. The Regulations do not prescribe limits on the number of Type A packages transported on a conveyance. It is not unusual for Type A packages to be transported together, sometimes in large numbers. As a result, it is possible for the source term in the event of an accident involving these shipments to be greater than the release from a single damaged package. However, it is considered unnecessary to constrain the size of the potential source term by limiting the number of Type A packages on a conveyance. Most Type A packages carry a small fraction of an A_1 or A_2 quantity; indeed only a small percentage of consignments of Type A packages comprise more than the equivalent of one full Type A package. A study undertaken in the United Kingdom [1] found that the highest loading of a conveyance with many Type A packages was equivalent to less than five full Type A packages. Experience also indicates that Type A packages perform well in many accident conditions. Combining event data from the USA [2] and the United Kingdom [3] over a period of about 20 years provides information on 22 accidents involving consignments of multiple Type A packages. There was a release of radioactive contents in only two of these events. Both led to releases in the order of $10^{-4} A_2$. A further example can be found in the description of an accident that happened in the USA in 1983 [4] with a conveyance carrying 82 packages (Type A and excepted) with a total of approximately $4 A_2$ on board. Two packages were destroyed, releasing material with an activity of approximately $10^{-4} A_2$.

401.3. Table I of the Regulations includes activity concentration limits and activity limits for consignments which may be used for exempting materials and consignments from the requirements of the Regulations, including applicable administrative requirements. If a material contains radionuclides where either the activity concentration or the activity for the consignment is less than the limits in Table I, then the shipment of that material is exempt (i.e. the Regulations do not apply; see para. 236). The general principles for exemption [5] are that:

- (a) the radiation risks to individuals caused by the exempted practice or source be sufficiently low as to be of no regulatory concern;
- (b) the collective radiological impact of the exempted practice or source be sufficiently low as not to warrant regulatory control under the prevailing circumstances; and
- (c) the exempted practices and sources be inherently safe, with no appreciable likelihood of scenarios that could lead to a failure to meet the criteria in (a) and (b).

401.4. Exemption values in terms of activity concentrations and total activity were initially derived for inclusion in the Basic Safety Standards [5] on the following basis [6]:

- (a) an individual effective dose of 10 μSv in a year for normal conditions;
- (b) a collective dose of 1 man Sv in a year of practice for normal conditions.

The exemption values were derived by using a variety of exposure scenarios and pathways that did not explicitly address the transport of radioactive material. Additional calculations were performed for transport specific scenarios [7]. These transport specific exemption values were then compared with the values in the Basic Safety Standards. It was concluded that the relatively small differences between both sets did not justify the incorporation into the Regulations of a set of exemption values different from that in the Basic Safety Standards, given that the use of different exemption values in various practices may give rise to problems at interfaces and may cause legal and procedural complications.

401.5. For radionuclides not listed in the Basic Safety Standards, exemption values were calculated by using the same method [6].

401.6. The activity concentration exemption values are to be applied to the radioactive material within a packaging or in or on a conveyance.

401.7. Exemption values for 'total activity' have been established for the transport of small quantities of material for which, when transported together, the total activity is unlikely to result in any significant radiological exposure even when exemption values for 'activity concentration' are exceeded. The exemption values for 'total activity' are therefore established on a per consignment basis rather than on a per package basis.

401.8. It must be emphasized that, in the case of decay chains, the values in Table I, columns 4 and 5, of the Regulations relate to the activity or activity concentration of the parent nuclide.

DETERMINATION OF BASIC RADIONUCLIDE VALUES

403.1. In the event that A_1 or A_2 values need to be calculated, the methods outlined in Appendix I should be used. Two situations are considered here. First, for a radionuclide with a decay chain including one or more radionuclides in equilibrium in which the half-lives of all progeny (daughters) are less than 10 d and in which no progeny radionuclide has a half-life longer than the parent nuclide; and, second, any other situation. In the former case, only the chain parent should be considered because the contribution of the daughters was considered in developing the A_1/A_2 values (see Appendix I) whereas, in the latter case, all the nuclides should be considered separately and as a mixture of radionuclides, in accordance with para. 404 of the Regulations.

403.2. In the event that exemption values need to be calculated, the methods used to derive the values in the Basic Safety Standards, as outlined in Ref. [6], should be used.

404.1. See Appendix I.

404.2. Reactor plutonium recovered from low enriched uranium spent fuel (less than 5% U-235) constitutes a typical example of a mixture of radionuclides with known identity and quantity for each constituent. Calculations according to para. 404 of the Regulations result in activity limits independent of the abundance of the plutonium radionuclides and the burnup within the range 10 000–40 000 MW-d/t. The following values for reactor plutonium can be used within the above range of burnup, the Am-241 buildup taken into account, up to five years after recovery:

$$\begin{aligned}A_1 &= 20 \text{ TBq} \\A_2 &= 3 \times 10^{-3} \text{ TBq}\end{aligned}$$

It is emphasized that these values can be applied only in the case of plutonium separated from spent fuel from thermal reactors, where the original fuel comprised uranium enriched up to 5% in U-235, where the burnup was in the range not less than 10 000 MW-d/t to not more than 40 000 MW-d/t, and where the separation was carried out less than five years before completion of the transport operation. It will also be necessary to consider separately other contaminants in the plutonium.

405.1. For mixtures of radionuclides where the identity is known but the relative proportions are not known in detail, a simplified method to determine the basic radionuclide values is given. This is particularly useful in the case of mixed fission products, which will almost invariably contain a proportion of transuranic nuclides.

In this case the grouping would simply be between alpha emitters and other emitters, using the most restrictive of the respective basic radionuclide values for the individual nuclides within each of the two groups. Knowledge of the total alpha activity and remaining activity is necessary to determine the activity limits on the contents. By using this method for the particular fission product mixture present, it is possible to account for both the risk from transuranic elements and that from the fission products themselves. The relative risks will depend upon the origin of the mixture, i.e. the fissionable nuclide origin, the irradiation time, the decay time and possibly the effects of chemical processing.

405.2. For reprocessed uranium, A_2 values may be calculated by using the equation for mixtures in para. 404 and taking account of the physical and chemical characteristics likely to arise in both normal and accident conditions. It may also be possible to demonstrate that the A_2 value is unlimited by showing that 10 mg of the uranium will have less activity than that giving rise to a committed effective dose of 50 mSv for that mixture. In addition, for calculating A_2 values in the case of reprocessed uranium, the advice given in Ref. [8] may provide useful information.

406.1. Table II of the Regulations provides default data for use in the absence of known data. The values are the lowest possible values within the alpha or beta/gamma subgroups.

CONTENTS LIMITS FOR PACKAGES

Excepted packages

409.1. Articles manufactured from natural or depleted uranium are by definition LSA-I and hence would normally have to be transported in an Industrial package Type 1 (IP-1). However, provided the materials are contained in an inactive sheath made of metal or other substantial material they may be transported in excepted packages. The sheath is expected to prevent oxidation or abrasion, absorb all alpha radiation, reduce the beta radiation levels and reduce the potential risk of contamination.

410.1. See para. 579.1.

Industrial packages Type 1, Type 2 and Type 3

411.1. See paras 521.1 and 525.1.

Type B(U) and Type B(M) packages

415.1. Contents limits for Type B(U) and Type B(M) packages are specified on the approval certificates.

416.1. For Type B(U) and Type B(M) packages to be transported by air, the contents limits are further restricted to the lower of $3000 A_1$ or $100\,000 A_2$ for special form material and $3000 A_2$ for all other radioactive material.

416.2. The $3000 A_2$ limit for non-special form material was established taking into account risk analysis work by Hubert et al. [9] concerning Type B package performance in air transport accidents. It is also the threshold quantity for which shipment approval of Type B(M) packages is required.

416.3. With regard to the radioactive contents limit for special form radioactive material, it follows from the Q system that $3000 A_1$ was adopted as the radioactive content limit for such material in parallel to the $3000 A_2$ radioactive contents limit. However, for certain alpha emitters the ratio A_1 to A_2 can be as high as 10^4 , which would lead to effective potential package loadings of $3 \times 10^7 A_2$ not in dispersible form. This was seen as an undesirably high level of radioactive content, particularly if the special form was partially disrupted in a very severe accident. It was assumed that the similarity between the special form impact test and the Type B impact test implies that special form may be expected to provide a 10^2 reduction in release comparable to a Type B package, allowing the source to increase by a factor of 100 to $300\,000 A_2$. The value of $100\,000 A_2$ was taken as a conservative estimate.

416.4. Radioactive material in a non-dispersible form or sealed in a strong metallic capsule presents a minimal contamination hazard, although the direct radiation hazard still exists. Additional protection provided by the special form definition is sufficient to ship special form material by air in a Type B(U) package up to an activity of $3000 A_1$ but not more than $100\,000 A_2$ of the special form nuclide. French studies indicated that some special form material approved under current standards may retain its containment function under test conditions for air accidents [9].

Type C packages

417.1. The design of a Type C package must limit the potential releases to acceptable levels should the package be involved in a severe air accident. The contents limits for Type C packages, as specified on the approval certificates, take into account the testing requirements for a Type C package, which reflect the potentially very severe accident forces that could be encountered in a severe air transport accident. The design must

also ensure that the form of the material and the physical or chemical states are compatible with the containment system.

Packages containing fissile material

418.1. It is important that the fissile material contents in a package should comply with the approved description of the package contents because criticality safety can be sensitive to the quantity, type, form and configuration of fissile material, any fixed neutron poisons, and/or other non-fissile material included in the contents. Care should be taken to include in the description of the authorized contents any materials (e.g. inner receptacles, packing materials, void displacement pieces) or significant impurities that possibly or inherently may be present in the package. Thus, the safety assessment should carefully consider the full range of parameters that characterize all material intended as possible contents in the package. Compliance with the quantity of fissile material specified in the certificate of approval is important because any change could cause a higher neutron multiplication factor owing to more fissile material or, in the case of less fissile material, could potentially allow a higher reactivity caused by an altered optimal water moderation (for example, the certificate may need to require complete fuel assemblies to be shipped – with no pins removed). Including fissile material or other radionuclides not authorized for the package can have an unexpected effect on criticality safety (for example, replacing U-235 by U-233 can yield a higher multiplication factor). Similarly, the placement of the same quantity of fissile material in a heterogeneous or homogeneous distribution can significantly affect the multiplication factor. A heterogeneous lattice arrangement provides a higher reactivity for low enriched uranium systems than a homogeneous distribution of the same quantity of material.

Packages containing uranium hexafluoride

419.1. The limit for the mass of uranium hexafluoride in a loaded package is specified in order to prevent overpressurization during both filling and emptying. This limit should be based upon the maximum uranium hexafluoride working temperature of the cylinder, the certified minimum internal volume of the cylinder, a minimum uranium hexafluoride purity of 99.5%, and a minimum safety margin of 5% free volume when the uranium hexafluoride is in the liquid state at the maximum working temperature [10].

419.2. The requirement that the uranium hexafluoride be in solid form and that the internal pressure inside the uranium hexafluoride cylinder be below atmospheric pressure when presented for transport was established as a safe method of operation and to provide the maximum possible safety margin for transport. Generally,

cylinders are filled with uranium hexafluoride at pressures above atmospheric pressure under gaseous or liquid conditions. Until the uranium hexafluoride is cooled and solidified, a failure of the containment system in either the cylinder or the associated plant fill system could result in a dangerous release of uranium hexafluoride. However, since the triple point of uranium hexafluoride is 64°C at normal atmospheric pressure of 1.013×10^5 Pa, if the uranium hexafluoride is presented for transport in a thermally steady state, solid condition, it is unlikely that during normal conditions of transport it will exceed the triple point temperature.

419.3. Satisfying the requirement that the uranium hexafluoride be in solid form with an internal cylinder pressure less than atmospheric pressure for transport ensures that: (a) the handling of the cylinder prior to and following transport and transport under normal conditions will occur with the greatest safety margin relative to the package performance; (b) the structural capabilities of the package are maximized; and (c) the containment boundary of the package is functioning properly. Satisfying this requirement precludes cylinders being presented for transport which have not been properly cooled after the filling operation.

419.4. The above criteria for establishing fill limits and the specific fill limits for the uranium hexafluoride cylinders most commonly used throughout the world are specified in Ref. [10]. Fill limits for any other uranium hexafluoride cylinder should be established using these criteria and, for any cylinder requiring competent authority approval, the analysis establishing the fill limit and the value of the fill limit should be included in the safety documentation submitted to the competent authority. A safe fill limit should accommodate the internal volume of the uranium hexafluoride when in heated, liquid form, and, in addition, an allowance for ullage (i.e. the gas volume) above the liquid in the container should be provided.

419.5. Uranium hexafluoride exhibits a significant expansion when undergoing the phase change from solid to liquid. The uranium hexafluoride expands from a solid at 20°C to a liquid at 64°C by 47% (from 0.19 cm³/g to 0.28 cm³/g). In addition, the liquid uranium hexafluoride will expand an additional 10% based on the solid volume (from 0.28 cm³/g at the triple point to 0.3 cm³/g) when heated from 64 to 113°C. As a result, an additional substantial increase in volume of the uranium hexafluoride between the minimum fill temperature and the higher temperatures can occur. Therefore, extreme care should be taken by the designer and the operator at the facility where uranium hexafluoride cylinders are filled to ensure that the safe fill limit for the cylinder is not exceeded. This is especially important since, if care is not taken, the quantity of material which can be added to a cylinder could greatly exceed the safe fill limit at the temperature where uranium hexafluoride is normally transferred into cylinders (e.g. at temperatures of about 71°C). For example, a 3964 L cylinder, with

a fill limit of 12 261 kg, could accept up to 14 257 kg of uranium hexafluoride at 71°C. When heated above 71°C, the liquid uranium hexafluoride would completely fill the cylinder and could hydraulically deform and rupture the cylinder. Quantities of uranium hexafluoride above 14 257 kg would rupture the cylinder if heated above 113°C. Hydraulic rupture is a well understood phenomenon, and it should be prevented by adhering to established fill limits based on the cylinder certified minimum volume and a uranium hexafluoride density at 121°C for all cylinders or the maximum temperature relating to the design of the cylinder [11].

419.6. Prior to shipment of a uranium hexafluoride cylinder, the consignor should verify that its internal pressure is below atmospheric pressure by measurement with a pressure gauge or another suitable pressure indicating device. This is consistent with ISO 7195, which indicates that a subatmospheric cold pressure test should be used to demonstrate suitability of the cylinder for transport of uranium hexafluoride. According to ISO 7195, a cylinder of uranium hexafluoride should not be transported unless the internal pressure is demonstrated to be at a partial vacuum of 6.9×10^4 Pa. The operating procedure for the package should specify the maximum subatmospheric pressure allowed, measured in this fashion, which will be acceptable for shipment; and the results of this measurement should be included in appropriate documentation. This prior-to-shipment test should also be accomplished subject to agreed quality assurance procedures.

REFERENCES TO SECTION IV

- [1] AMERSHAM INTERNATIONAL plc, in communication with the National Radiological Protection Board, provided inventory data of packages aboard conveyances (1986).
- [2] FINLEY, N.C., McCLURE, J.D., REARDON, P.C., WANGLER, M., "An analysis of the consequences of accidents involving shipments of multiple Type A radioactive material packages", PATRAM 89 (Proc. Symp. Washington, DC, 1989), Oak Ridge National Laboratory, Oak Ridge, TN (1989).
- [3] GELDER, R., MAIRS, J.H., SHAW, K.B., "Radiological impact of transport accidents and incidents in the UK over a twenty year period", Packaging and Transportation of Radioactive Materials, PATRAM 86 (Proc. Symp. Davos, 1986), IAEA, Vienna (1986).
- [4] MOHR, P.B., MOUNT, M.E., SCHWARTZ, M.E., "A highway accident involving radiopharmaceuticals near Brookhaven, Mississippi on December 3, 1983", Rep. UCRL 53587 (NUREG/CR 4035), US Nuclear Regulatory Commission, Washington, DC (1985).
- [5] FOOD AND AGRICULTURE ORGANIZATION OF THE UNITED NATIONS, INTERNATIONAL ATOMIC ENERGY AGENCY, INTERNATIONAL LABOUR ORGANISATION, OECD NUCLEAR ENERGY AGENCY, PAN AMERICAN

- HEALTH ORGANIZATION, WORLD HEALTH ORGANIZATION, International Basic Safety Standards for Protection against Ionizing Radiation and for the Safety of Radiation Sources, Safety Series No. 115, IAEA, Vienna (1996).
- [6] EUROPEAN COMMISSION, Principles and Methods for Establishing Concentrations (Exemption Values) below which Reporting is not Required in the European Directive, Radiation Protection Report No. 65, EC, Brussels (1993).
- [7] FRANÇOIS, P., et al., “The application of exemption values to the transport of radioactive materials”, IRPA 9 (Proc. 9th IRPA Int. Congr. Vienna, 1996), Vol. 4, IRPA, Vienna (1996) 674.
- [8] INTERNATIONAL ATOMIC ENERGY AGENCY, Interim Guidance for the Safe Transport of Reprocessed Uranium, IAEA-TECDOC-750, IAEA, Vienna (1994).
- [9] HUBERT, P., et al., Specification of Test Criteria and Probabilistic Approach: The Case of Plutonium Air Transport Probabilistic Safety Assessment and Risk Management, PSA 87, Verlag TÜV Rheinland, Cologne (1987).
- [10] INTERNATIONAL ORGANIZATION FOR STANDARDIZATION, Packaging of Uranium Hexafluoride (UF₆) for Transport, ISO 7195:1993(E), ISO, Geneva (1993).
- [11] UNITED STATES ENRICHMENT CORPORATION, Reference USEC-651, USEC, Washington, DC (1998).

Section V

REQUIREMENTS AND CONTROLS FOR TRANSPORT

REQUIREMENTS BEFORE THE FIRST SHIPMENT

501.1. For ensuring safe transport of radioactive material, general requirements for quality assurance (para. 310) and compliance assurance (para. 311) have been established in the Regulations. Specific inspection requirements to assure compliance for those packaging features which have a major bearing on the integrity of the package and on radiation and nuclear criticality safety have also been established. These requirements cover inspections both prior to the first shipment and prior to each shipment. The requirements in para. 501 relating to shielding, containment, heat transfer and criticality safety (confinement system effectiveness and neutron poison characteristics) of specific packagings were determined to be those important design/fabrication features related to safety which need to be verified at the end of fabrication and prior to use.

501.2. In the design phase of the package, documents should be prepared to define how the requirements of para. 501 are fully complied with for each manufactured packaging. Each document required should be authorized (e.g. signed) by the persons directly responsible for each stage of manufacture. Specific values should be recorded, even when within tolerance. The completed documents should be retained on file in conformance with quality assurance requirements (see para. 310).

501.3. In the case of a containment system having a design pressure exceeding 35 kPa, as required in para. 501(a), it should be confirmed that the containment system in the as-fabricated state is sufficient. This may be accomplished, for instance, through a test. For packagings with fill/vent valves, these openings can be used to pressurize the containment system to its design pressure. If the containment system does not have such penetrations, the vessel and its closure may require separate testing using special fixtures. During these tests, seal integrity should be evaluated using the procedures established for normal use of the package.

501.4. In performing the tests and inspections on packagings following fabrication to assess the effectiveness of shielding, to satisfy para. 501(b), the shielding components may be checked by a radiation test of the completed assembly. The radiation source for this test need not be the material intended to be transported, but care should be taken such that shielding properties are properly evaluated relative to energy, energy

spectrum and type of radiation. Particular attention should also be paid to the homogeneity of packaging materials and the possibility of increased localized radiation levels at joints. For methods of testing the integrity of a package's radiation shielding see Refs [1, 2] and paras 656.13–656.18.

501.5. Containment integrity should be assessed using appropriate leakage rate tests for compliance with para. 501(b); see paras 656.1–656.12 and 656.21–656.24.

501.6. Inspection of a packaging for heat transfer characteristics, in compliance with para. 501(b), should include a dimensional check and special attention to ventilation apertures, surface emissivity, and absorptivity and continuity of conduction paths. Proof tests, which may normally be necessary only for a prototype package, may be conducted by using electrical heaters in place of a radioactive source.

501.7. Although the confinement system includes the package contents, only the packaging components of the confinement system need to be inspected and/or tested after fabrication and prior to the first shipment to comply with para. 501(b). Any inspection and/or testing of the fissile material should be performed prior to each shipment (see para. 502.2 or 501.8 as appropriate). Dimensional and material inspection of pertinent packaging components and welds should be completed to ensure the confinement system packaging components are fabricated and located as designed. Testing will most often involve assurance of the presence and distribution of the neutron poisons as discussed in para. 501.8.

501.8. In cases where criticality safety is dependent on the presence of neutron absorbers as referred to in para. 501(c), it is preferred that the neutron absorber be a solid and an integral part of the packaging. Solutions of absorbers, or absorbers that are water soluble, are not endorsed for this purpose because their continued presence cannot be assured. The confirmation procedure or tests should ensure that the presence and distribution of the neutron absorber within the packaging components are consistent with those assumed in the criticality safety assessment. Merely ensuring the quantity of the neutron absorbing material is not always sufficient because the distribution of the neutron absorbers within a packaging component, or within the packaging contents itself, can have a significant effect on the neutron multiplication factor for the system. Uncertainties in the confirmation technique should be considered in verifying consistency with the criticality safety assessment.

501.9. For further information see Refs [3, 4].

REQUIREMENTS BEFORE EACH SHIPMENT

502.1. In addition to the requirements imposed by ST-1 on certain packages prior to their first shipment (para. 501), certain other requirements in ST-1 (para. 502) are to be satisfied prior to each shipment of any package to enhance compliance and assure safety. These requirements include inspection to ensure that only proper lifting attachments are used during shipment, and verification that requirements in approval certificates are complied with and thermal and pressure stability have been demonstrated. In all cases these requirements are deemed necessary to reduce the possibility of having an unsafe package shipped in the public domain and are aimed at prevention of human error.

502.2. Inspection and test procedures should be developed to ensure that the requirements of paras 502(a) and 502(b) are satisfied. Compliance should be documented as part of the quality assurance programme (see para. 310).

502.3. The certificate of approval (see paras 502(c)–(h)) is the evidence that a package design of an individual package meets the regulatory requirements and that the package may be used for transport. The provisions of para. 502 are designed to ensure that the individual package continues to comply with these requirements. Each check should be documented and authorized (e.g. signed) by the person directly responsible for this operation. Specific values should be recorded, even when within tolerances, and compared with results of previous tests, so that any indication of deterioration may become apparent. The completed documents should be retained on file in conformance with quality assurance requirements (see para. 310).

502.4. The approval certificates for packages containing fissile material indicate the authorized contents of the package (see paras 418 and 833). Prior to each shipment, the fissile material contents should be verified to have the characteristics provided in the listing of authorized contents. When removable neutron poisons or other removable criticality control features are specifically allowed by the certificate, inspections and/or tests, as appropriate, should be made to ascertain the presence, correct location(s) and/or concentration(s) of those neutron poisons or control features. Solutions of absorbers or absorbers that are water soluble are not endorsed for this purpose because their continued presence cannot be ensured. The confirmation procedure or tests should ensure that the presence, correct location(s) and/or concentration(s) of the neutron absorber or control features within the package are consistent with those assumed in the criticality safety assessment. Merely ensuring the quantity of the control material is not always sufficient because the distribution within the package can have a significant effect on the reactivity of the system.

502.5. To be in compliance with para. 502(d), detailed procedures should be developed and followed to ensure that steady state conditions have been reached by measuring the temperature and pressure over a defined period. In the performance of any test it should be ensured that the method selected provides the required sensitivity and does not degrade the integrity of the package. Non-conformance with the approved design requirements should be fully documented and also reported to the competent authority which approved the design.

502.6. Every Type B(U), Type B(M) and Type C package should be tested, after closure and before transport, to ensure compliance with the required leaktightness standard (see para. 502(e)). Some national authorities may permit an assembly verification procedure followed by a less stringent leakage test as offering equivalent confidence in meeting the design conditions. An example of an assembly verification procedure would be:

First inspect and/or test comprehensively the complete containment system of an empty packaging. The radioactive contents may then be loaded into the packaging and only the closure components which were opened during loading need be inspected and/or tested as part of the assembly verification procedure.

In the case of packages where containment is provided by radioactive material in special form, compliance may be demonstrated by possession of a certificate prepared under a quality assurance programme which demonstrates the leaktightness of the source(s) concerned. The competent authority of the country concerned should be consulted if such a procedure is envisaged.

502.7. The leak test requirements for Type B(U), Type B(M) and Type C packages, including tests performed, frequency of testing and test sensitivity, are based on the maximum allowable leak rates and standardized leak rates calculated for the package for normal and accident conditions as described in ISO 12807 [5]. Highly sensitive pre-shipment leakage testing may not be necessary for some Type B packages, depending for example on the material contained and the related allowable leak rate. An example of such a material could be one that exceeds the specific activity limit for LSA-II material, but not qualifying as LSA-III. The physical characteristics of such a material might include a limited activity concentration and a physical form which reduces dispersibility of the material as discussed in paras 226.14–226.20. Packages carrying such a material may require pre-shipment leak tests but the tests could be simple direct tests, such as gas and soap bubble qualitative tests or gas pressure drop and rise quantitative tests, as described in ISO 12807 or ANSI N.14.5-1977 [4].

502.8. Concerning para. 502(g), the measurement specified by para. 674(b) should verify that the irradiated nuclear fuel falls within the envelope of conditions demonstrated in the criticality safety assessment to satisfy the criteria of paras 671–682. Typically, the primary conditions proposed for use in the safety assessment of irradiated nuclear fuel at a known enrichment are the burnup and decay characteristics and, as such, these are the parameters that should be verified by measurement. The measurement technique should depend on the likelihood of misloading the fuel and the amount of available subcritical margin due to irradiation. For example, as the number of fuel elements of varying irradiation stored in the reactor pond and the length of time between discharge and shipment increase, so the likelihood of misloading increases. Similarly, if an irradiation of 10 GW·d/MTU is used in the criticality assessment, but fuel of less than 40 GW·d/MTU is not permitted by the package design certificate to be loaded into the package, a measurement verification of irradiation using a technique with a large uncertainty may be adequate. However, if an irradiation of 35 GW·d/MTU is used in the criticality assessment, the measurement technique to verify irradiation should be much more reliable. The measurement criteria that should be met to allow the irradiated material to be loaded and/or shipped should be clearly specified in the certificate of approval. See Refs [6–9] for information on measurement approaches in use [6] or proposed for use [7–9].

502.9. The approval certificate should identify any requirements for closure of a package containing fissile material which are necessary as a result of the assumptions made in the criticality safety assessment relative to water in-leakage for a single package in isolation (see para. 677). Inspections and/or tests should be made to ascertain that any special features for prevention of water in-leakage have been met.

TRANSPORT OF OTHER GOODS

504.1. The purpose of this requirement is to prevent radioactive contamination of other goods. See also paras 513.1–513.4 and para. 514.1.

505.1. This provision makes it possible for the consignor to include in the exclusive use consignment other goods destined to the same consignee under the conditions specified. The consignor has primary responsibility for ensuring compliance.

506.1. Dangerous goods may react with one another if allowed to come into contact. This could occur, for instance, as a result of leakage of a corrosive substance or of an accident causing an explosion. To minimize the possibility of radioactive material packages losing their containment integrity owing to the interaction of the package with other dangerous goods, they should be kept segregated from other dangerous

cargo during transport or storage. The extent of segregation required is usually established by individual States or the cognizant transport organizations (International Maritime Organization (IMO), International Civil Aviation Organization (ICAO), etc.).

506.2. Information on specific storage, stowage and segregation requirements, as applicable, is contained in the transport regulatory documents of international transport organizations [10–15] and in provisions laid down in regulatory documents of individual States. As these regulations and provisions are frequently amended, the current editions should be consulted in order to ascertain the latest requirements.

OTHER DANGEROUS PROPERTIES OF CONTENTS

507.1. The Regulations provide an acceptable level of control of the radiation and criticality hazards associated with the transport of radioactive material. With one exception (UF_6) the Regulations do not cover hazards that may be due to the physical/chemical form in which radionuclides are transported. In some cases, such subsidiary hazards may exceed the radiological hazards. Compliance with the provisions of the Regulations therefore does not absolve its users from the need to consider all of the other potential dangerous properties of the contents.

507.2. This edition of the Regulations includes, for the first time, provisions regarding packaging requirements for uranium hexafluoride (UF_6), based on both the relevant hazards, i.e. the radiological/criticality and the chemical hazards. Uranium hexafluoride is the only commodity for which such subsidiary hazards have been taken into account in the formulation of provisions in these Regulations (see para. 629).

507.3. The United Nations Recommendations on the Transport of Dangerous Goods [16] classifies all radioactive material in Class 7, though the other dangerous properties of some materials (such as excepted radioactive material with multiple hazards) may be more significant. The United Nations Recommendations prescribe performance tests for packagings for all dangerous goods and classify them as follows:

- Class 1 – Explosives
- Class 2 – Gases (compressed, liquefied, dissolved under pressure or deeply refrigerated)
- Class 3 – Flammable liquids
- Class 4 – Flammable solids; substances liable to spontaneous combustion; substances which, on contact with water, emit flammable gases
- Class 5 – Oxidizing substances; organic peroxides

- Class 6 – Toxic and infectious substances
- Class 7 – Radioactive material
- Class 8 – Corrosive substances
- Class 9 – Miscellaneous dangerous substances and articles.

507.4. In addition to meeting the requirements of the Regulations for their radioactive properties, radioactive consignments must comply with the requirements specified by relevant international transport organizations and applicable provisions adopted by individual States for any other hazardous properties. This includes, for example, requirements on labelling and information to be provided in the transport documents, and may also include additional package design requirements and approvals by appropriate authorities.

507.5. Where the packaging requirements specified by relevant international standards organizations for a subsidiary hazard are more severe than those quoted in the IAEA Regulations for the radiological hazard, the requirements for the subsidiary hazard will set the standard [16].

507.6. For radioactive material transported under pressure, or where internal pressure may develop during transport under the temperature conditions specified in the Regulations, or when the package is pressurized during filling or discharge, the package may fall under the scope of pressure vessel codes of the Member States concerned.

507.7. Performance tests for packagings of goods with hazardous properties other than radioactivity are prescribed in the United Nations Recommendations [16].

507.8. Additional labels denoting subsidiary hazards should be displayed as specified by the national and international transport regulations.

507.9. Since the regulations promulgated by the international transport organizations as well as by individual Member States are frequently amended, their current editions should be consulted to ascertain what additional provisions apply with respect to subsidiary hazards.

REQUIREMENTS AND CONTROLS FOR CONTAMINATION AND FOR LEAKING PACKAGES

508.1. The Regulations prescribe limits for non-fixed contamination on the surfaces of packages and conveyances under routine conditions of transport (see para. 106).

The limits for the surfaces of packages derive from a radiological model developed by Fairbairn [17] for the 1961 edition of the Regulations. In summary, the pathways of exposure were external beta irradiation of the skin, ingestion and the inhalation of resuspended material. Consideration of radionuclides was limited to the most hazardous radionuclides in common use, namely, Pu-239 and Ra-226 in the case of alpha emitters and Sr-90 in the case of beta emitters. These derived limits correspond to values that were generally accepted for laboratory and plant working areas and were thus conservative in the context of transport packages for which exposure time and handling time for workers were expected to be very much less than for workers in laboratories or active plants. Since this derivation, although there have been changes in radiological protection parameters, the transport contamination limits have not been changed. During the development of the 1996 edition of the Regulations, a radionuclide specific approach was rejected on the grounds that it would be impracticable and unnecessary and the current limits were viewed as continuing to be sufficiently cautious. Irrespective of the method used to determine the limit, optimization plays a role in reducing contamination levels on transport packages to levels that are as low as reasonably achievable, with due regard to the dose accrued during decontamination. The existing values give rise to low doses during transport.

508.2. In the case of packages contaminated with an alpha emitter, the pathway of exposure that usually determines a derived limit for contamination is the inhalation of material that has been resuspended from the surfaces of packages. The value of a relevant resuspension factor (in Bq/cm^3 per Bq/cm^2) is uncertain but research in the field was reviewed in a report published in 1979 [18]. The wide range of reported values spans the value recommended for general use by the IAEA [19] of $5 \times 10^{-5}/\text{m}$ which takes account of the probability that only a fraction of the activity resuspended may be in respirable form. In most cases the level of non-fixed contamination is measured indirectly by wiping a known area with a filter paper or a wad of dry cotton wool or other material of a similar nature. It is common practice to assume that the activity on the wipe represents only 10% of the total non-fixed contamination present on the surface. The fraction on the wipe will include the activity most readily available for resuspension. The remaining activity on the surface represents contamination that is less easily resuspended. An appropriate value for the resuspension factor for application to the total amount of non-fixed contamination on transport packages is of the order of $10^{-5}/\text{m}$. For an annual exposure time of 1000 h to an atmosphere containing contamination resuspended from the surfaces of packages contaminated with Pu-239 at $0.4 \text{ Bq}/\text{cm}^2$ and using a resuspension factor of $10^{-5}/\text{m}$, the annual effective dose is about 2 mSv. In the case of contamination with Ra-226, the annual effective dose would be of the order of 0.1 mSv. For most beta/gamma emitters the pathway of exposure that would determine a derived limit is exposure of the basal cells of the skin. The 1990 ICRP Recommendations [20] retain $7 \text{ mg}/\text{cm}^2$ as

the nominal depth of the basal cells, but extend the range of depth to 2–10 mg/cm². A number of studies [21–23] provide dose-rate conversion factors at a nominal depth of 7 mg/cm², or for the range 5–10 mg/cm². Skin contaminated by Sr-90/Y-90 at 4 Bq/cm² for 8 hours per working day would give rise to an equivalent dose to the skin of about 20 mSv/a, to be compared to an annual limit of 500 mSv [24]. This assumes a transfer factor of unity between package surfaces and skin.

508.3. In practice, contamination which appears fixed may become non-fixed as a result of the effects of weather, handling, etc. In most instances where small packages are slightly contaminated on the outer surfaces, the contamination is almost entirely removable or non-fixed, and the methods of measurement should reflect this. In some situations, however, such as in the case of fuel flasks which may have been immersed in contaminated cooling pond water whilst being loaded with irradiated fuel, this is not necessarily so. Contaminants such as Cs-137 may strongly adhere onto, or penetrate into, steel surfaces. Contamination may become ingrained in pores, fine cracks and crevices, particularly in the vicinity of lid seals. Subsequent weathering, exposure to rain or even exposure to moist air conditions may cause some fixed contamination to be released or to become non-fixed. Care is necessary prior to dispatch to utilize appropriate decontamination methods to reduce the level of contamination such that the limits of non-fixed contamination would not be expected to be exceeded during the journey. It should be recognized that on some occasions the non-fixed contamination limits may be exceeded at the end of the journey. However, this situation generally presents no significant hazard because of the pessimistic and conservative assumptions used in calculating the derived limits for non-fixed contaminations. In such situations the consignee should inform the consignor so that the latter can determine the causes and minimize such occurrences in the future.

508.4. In all cases, contamination levels on the external surfaces of packages should be kept as low as is reasonably achievable. The most effective way to ensure this is to prevent the surfaces from becoming contaminated. Loading, unloading and handling methods should be kept under review to achieve this. In the particular case of fuel flasks mentioned above, the pond immersion time should be minimized and effective decontamination techniques should be devised. Seal areas should be cleared by high pressure sprays, where possible, and particular care should be taken to minimize the presence of contaminated water between the body and lid of the flask. The use of a 'skirt' to eliminate contact with contaminated water in cooling ponds can prevent contamination of surfaces of the flask. If this is not possible, the use of strippable paints, pre-wetting with clean water and initiating decontamination as soon as possible may significantly reduce contamination uptake. Particular attention should be paid to removing contamination from joints and seal areas. Surface soiling should also be avoided wherever possible. Wiping a dirty surface both removes dirt and abrades the

underlying substrate, especially if the latter is relatively soft, e.g. paint or plastic. Thus soiling can contribute to non-fixed contamination either by the loose dirt becoming contaminated itself or by wiping of the dirty surface generating loose contamination from the underlying substrate. Paints and plastics weather on exposure to sunlight. Amongst other effects, ultraviolet light oxidizes paint or plastic surfaces, thus increasing cation exchange capacity. This renders surfaces exposed to the environment increasingly contaminable by some soluble contaminants.

508.5. It should be kept in mind that, if all packages were contaminated close to the limits, the routine handling and storage of packages in transit stores, airport terminals, rail marshalling yards, etc., could lead to buildup of contamination in working areas. Checks should be made to ensure that such buildup does not occur in areas where packages are regularly handled. Similarly, it is advisable to occasionally check gloves or other items of clothing of personnel routinely handling packages.

508.6. The Regulations set no specific limits for the levels of fixed contamination on packages, since the external radiation resulting therefrom will combine with the penetrating radiation from the contents, and the net radiation levels for packages are controlled by other specific requirements. However, limits on fixed contamination are set for conveyances (see para. 513) to minimize the risk that it may become non-fixed as a result of abrasion, weathering, etc.

508.7. In a few cases, a measurement of contamination may be made by directly reading contamination monitors. Such a measurement will include both fixed and non-fixed contamination. This will only be practicable where the level of background radiation from the installation in which the measurement is made or the radiation level from the contents does not interfere. In most cases the level of non-fixed contamination will have to be measured indirectly by wiping a known area for a smear and measuring the resultant activity of the smear in an area not affected by radiation background from other sources.

508.8. The derived limits for non-fixed contamination apply to the average level over an area of 300 cm² or the total package if its total surface area is less than 300 cm². The level of non-fixed contamination may be determined by wiping an area of 300 cm² by hand with a filter paper, a wad of dry cotton wool or other material of similar nature. The number of smear samples taken on a larger package should be such as to be representative of the whole surface and should be chosen to include areas known or expected to be more contaminated than the remainder of the surface. For routine surveys on a very large package such as on an irradiated fuel flask, it is common practice to select a large number of fixed general positions to assist in identifying patterns and trends. Care should be taken that not exactly the same position is

wiped on each occasion since this would leave large areas never checked and would tend to 'clean' the areas checked.

508.9. The activity of the smear sample may be measured either with a portable contamination monitor or in a standard counting castle. Care is necessary in converting the count rate to surface activity as a number of factors such as counting efficiency, geometrical efficiency, counter calibration and the fraction of contamination removed from the surface to the smear sample will affect the final result.

508.10. To avoid underestimation, the beta energy of the calibration source used for a counter should not be greater than the beta energies of the contaminant being measured. The fraction of contamination removed by the wipe test can, in practice, vary over a wide range and is dependent on the nature of the surface, the nature of the contaminant, the pressure used in wiping, the contact area of the material used for the test, the technique of rubbing (e.g. missing parts of the 300 cm² area or doubly wiping them) and the accuracy with which the operator estimates the area of 300 cm². It is common practice to assume that the fraction removed is 10%. This is usually viewed as being conservative, i.e. it results in overestimating the level of contamination. Other fractions may be used, but only if determined experimentally.

508.11. Users should develop specific contamination measurement techniques relevant to their particular circumstances. Such techniques include the use of smears and appropriate survey instruments. The instruments and detectors selected should take into account the likely radionuclides to be measured. Particular care should be taken in selecting instruments of appropriate energy dependence when low energy beta or alpha emitters are present. It should be recognized that the size of the smear and the size of the sensitive area of the detector are important factors in determining overall efficiency.

508.12. Operators should be adequately trained to ensure that samples are obtained in a consistent manner. Comparison between operators may be valuable in this respect. Attention is drawn to the difficulties which will occur if different organizations use techniques which are not fully compatible — especially in circumstances where it is not practical to maintain the levels of non-fixed contamination at near zero values.

509.1. See paras 508.1–508.12.

510.1. The prime purpose of inspection by a qualified person is to assess whether leakage or loss of shielding integrity has occurred or could be expected to occur, and either give assurance that the package is safe and within the limits prescribed in the Regulations or, if this is not so, assess the extent of the damage or leakage and the

radiological implications. On rare occasions it may be necessary to extend surveys and investigations back along the route, the conveyances and the handling facilities to identify and clean up any contaminated areas. Investigations may need to include the assessment of external dose and possible radioactive intake by transport workers and members of the public.

510.2. Vehicles containing damaged packages which appear to be leaking, or appear to be severely dented or breached, should be detained and secured until they have been declared safe by a qualified person.

513.1. Conveyances may become contaminated during the carriage of radioactive material by the non-fixed contamination on the packages. If the conveyance has become contaminated above this level, it should be decontaminated to at least the appropriate limit. This provision does not apply to the internal surfaces of a conveyance provided that the conveyance remains dedicated to the transport of radioactive material or surface contaminated objects under exclusive use (see para. 514.1).

513.2. Limits are also set on fixed contamination to minimize the risk that it may become non-fixed as a result of abrasion, weathering, etc.

513.3. If the non-fixed contamination on a conveyance exceeds the limits laid down in para. 508 of the Regulations, the conveyance should be decontaminated and, following the decontamination, a measurement should be made of the fixed contamination. The radiation level resulting from the fixed contamination on the surfaces may be measured using a portable instrument of an appropriate range held near to the surface of the conveyance. Such measurements should only be made before the conveyance is loaded.

513.4. Where packages having relatively high levels of fixed contamination are handled regularly by the same transport workers, it may be necessary to consider not only the penetrating radiation but also the non-penetrating radiation from that contamination. The effective dose received by the workers from the penetrating radiation may be sufficiently low that no individual monitoring is necessary. If it is known that the fixed contamination levels may be high, then it may be prudent to derive a working limit that prevents undesirable exposure of the workers' hands.

513.5. For measurement of surface dose rates, see paras 233.1–233.6.

514.1. While it is normally good practice to decontaminate an overpack, freight container, tank, intermediate bulk container or conveyance as quickly as possible so that it can be used for transporting other substances, there are situations, e.g. transport

of uranium or thorium ores, where conveyances are essentially dedicated to the transport of radioactive materials, including unpackaged radioactive material, and are continually contaminated. In cases where the practice of using dedicated conveyances is common, an exception to the need for quickly decontaminating these conveyances, tanks, overpacks, intermediate bulk containers or freight containers, if applicable, is provided for as long as these conveyances, tanks, overpacks, intermediate bulk containers or freight containers remain in that dedicated use. Decontamination of the internal surfaces after every use could lead to unnecessary exposure of workers. On the other hand, the external surfaces which are continually being exposed to the environment, and which are generally much easier to decontaminate, should be decontaminated to below the applicable limits after each use. It should be noted that para. 414 of the 1985 edition of the Regulations was restricted to low specific activity materials and surface contaminated objects. This provision is now extended to apply to all radioactive material.

REQUIREMENTS AND CONTROLS FOR TRANSPORT OF EXCEPTED PACKAGES

515.1. Excepted packages are packages in which the allowed radioactive content is restricted to such low levels that the potential hazards are insignificant and therefore no testing is required with regard to containment or shielding integrity (see also paras 517.1–517.5).

516.1. The requirement that the radiation level at the surface of an excepted package not exceed 5 $\mu\text{Sv/h}$ was established in order to ensure that sensitive photographic material will not be damaged and that any radiation dose to members of the public will be insignificant.

516.2. It is generally considered that radiation exposures not exceeding 0.15 mSv do not result in unacceptable fogging of undeveloped photographic film. A package containing such film would have to remain in contact with an excepted package having the maximum radiation level on contact of 5 $\mu\text{Sv/h}$ for more than 20 h in order to receive the prescribed radiation dose limit of 0.1 mSv (see paras 307.1–307.3).

516.3. By the same argument, special segregation of excepted packages from persons is not necessary. Any radiation dose to members of the public will be insignificant even if such a package is carried in the passenger compartment of a vehicle.

516.4. For measuring the radiation level, an appropriate instrument should be used, i.e. it should be sensitive to and calibrated for the type of radiation to be measured. In

most cases only penetrating radiation (gamma rays and neutrons) needs to be taken into account. For establishing the radiation level on the surface of a package, it is normally adequate to take the reading shown on the instrument when the instrument is held against the surface of the package. The instruments used should, where possible, be small compared with the size of the package. In view of the usually small dimensions of excepted packages, instruments with a small detection chamber (Geiger–Müller tube, scintillation meter or ionization chamber) are most suited for the purpose. The instrument should be reliable, in good condition, properly maintained and calibrated, and possess characteristics acceptable in good radiation protection practice.

517.1. The limits for radioactive material contents of excepted packages are such that the radioactivity hazard associated with a total release of contents is consistent with the hazard from a Type A package releasing part of its contents (see Appendix I).

517.2. Limits other than the basic limits are allowed where the radioactive material is enclosed in or forms a component part of an instrument or other manufactured article where an added degree of protection is provided against escape of material in the event of an accident. The added degree of protection is assessed in most cases as a factor of 10, thus leading to limits for such items which are 10 times as high as the basic limits. The factor of 10 used in this and the other variations from the basic limits are pragmatically developed factors.

517.3. The added degree of protection is not available in the case of gases so that the item limits for instruments and manufactured articles containing gaseous sources remain the same as the limits for excepted packages containing gaseous material not enclosed in an instrument or article.

517.4. Packaging reduces both the probability of the contents being damaged and the likelihood of radioactive material in solid or liquid form escaping from the package. Accordingly, the excepted package limits for instruments and manufactured articles incorporating solid or liquid sources have been set at 100 times the item limits for individual instruments or articles.

517.5. With packages of instruments and articles containing gaseous sources, the packaging may still afford some protection against damage, but it will not significantly reduce the escape of any gases which may be released within it. The excepted package limits for instruments and articles incorporating gaseous sources have therefore been set at only 10 times the item limits for the individual instruments or articles.

518.1. The basic activity limit for non-special form solid material which may be transported in an excepted package is $10^{-3} A_2$. This limit for an excepted package was

derived on the basis of the assumption that 100% of the radioactive contents could be released in the event of an accident. The maximum activity of the release in such an event, i.e. $10^{-3} A_2$, is comparable with the fraction of the contents assumed to be released from a Type A package in the dosimetric models used for determining A_2 values (see Appendix I).

518.2. In the case of special form solid material, the probability of release of any dispersible radioactive material is very small. Thus, if radiotoxicity were the only hazard to be considered, much higher activity limits could be accepted for special form solid materials in excepted packages. However, the nature of special form does not provide any additional protection where external radiation is concerned. The limits for excepted packages containing special form material are therefore based on A_1 rather than A_2 . The basic limit selected for special form solid material is $10^{-3} A_1$. This limits the external dose equivalent rate from unshielded special form material to one thousandth of the rate used to determine the A_1 values.

518.3. For gaseous material, the arguments are similar to those for solid material and the basic excepted package limits for gaseous material are therefore also $10^{-3} A_2$ for non-special form and $10^{-3} A_1$ for special form material. It is to be noted that in the case of elemental gases the package limits are extremely pessimistic because the derivation of A_2 already embodies an assumption of 100% dispersal (see Appendix I).

518.4. Tritium gas has been listed separately because the actual A_2 value for tritium is much greater than 40 TBq, which is the generally applicable maximum for A_2 values. The value of $2 \times 10^2 A_2$ is conservative in comparison with other gases even when allowing for conversion of tritium to tritiated water.

518.5. In the case of liquids, an additional safety factor of 10 has been applied because it was considered that there is a greater probability of a spill occurring in an accident. The basic excepted package limit for liquid material is therefore set at $10^{-4} A_2$.

519.1. The purpose of the inactive sheath is to cover the outer surfaces of the uranium or thorium to protect them from abrasion, to absorb the alpha radiation emitted and to reduce the beta radiation level at the accessible surfaces of the article. The sheath also may be used to control the oxidation of the uranium or thorium and the consequent buildup of non-fixed contamination on the outer surfaces of such articles.

519.2. Examples of articles manufactured from natural uranium, depleted uranium or natural thorium are aircraft counterweights made of depleted uranium and coated

with an epoxy resin, and uranium encased in metal and used as a shield in packagings for X ray and gamma ray radiography and medical treatment devices.

519.3. In the case of a depleted uranium shield incorporated in a packaging, the uranium should be sheathed with steel and the continuity of the envelope should be assured by careful seam welding. As an example, the national regulations in the United States of America stipulate that the steel sheath be at least 3.2 mm thick and the outside of the packaging be labelled showing that it contains uranium, to prevent it from inadvertently being machined or disposed of as scrap.

Additional requirements and controls for transport of empty packagings

520.1. Empty packagings which once contained radioactive material present little hazard provided that they are thoroughly cleaned to reduce the non-fixed contamination levels to the levels specified in para. 508 of the Regulations, have external surface radiation levels below 5 $\mu\text{Sv/h}$ (see para. 516) and are in good condition so that they may be securely resealed (see para. 520(a)); under these conditions the empty packaging may be transported as an excepted package.

520.2. The following examples describe situations where para. 520 is not applicable:

- (a) An empty packaging which cannot be securely closed owing to damage or other mechanical defects may be shipped by alternate means which are consistent with the provisions of the Regulations, for instance under special arrangement conditions;
- (b) An empty packaging containing residual radioactive material or internal contamination in excess of the non-fixed contamination limits as specified in para. 520(c) should only be shipped as a package category which is appropriate to the amount and form of the residual radioactivity and contamination.

520.3. Determining the residual internal activity within the interior of an 'empty' radioactive material packaging (see para. 520(c)) can be a difficult task. In addition to direct smears (wipes), various methods or combinations of methods which may be used include:

- gross activity measurement;
- direct measurement of radionuclides; and
- material accountability, e.g. by 'difference' calculations, from a knowledge of the activity or mass of the contents and the activity or mass removed in emptying the package.

Whichever method or combination of methods is used, care should be taken to prevent excessive and unnecessary exposure of personnel during the measuring process. Special attention should be paid to possible high radiation levels when the containment system of an empty packaging is open.

520.4. 'Heels' of residual material tend to build up in UF_6 packagings upon emptying. These 'heels' are generally not pure UF_6 but consist of materials (impurities) which do not sublime as readily as UF_6 , for example, UO_2F_2 , uranium daughters, fission products and transuranic elements. Steps should be taken upon emptying to ensure that the package meets the requirements of para. 520 if it is being shipped as an empty packaging; and upon refilling to ensure that radiation levels local to the 'heel' are not excessively high, that the transport documents properly account for the 'heel' and that the combined UF_6 contents and 'heel' satisfy the appropriate material requirements. Appropriate assessment and cleaning upon either emptying or refilling may be necessary to satisfy the relevant regulatory requirements. For further information see Refs [25, 26] and para. 549.5.

REQUIREMENTS AND CONTROLS FOR TRANSPORT OF LSA MATERIAL AND SCOs IN INDUSTRIAL PACKAGES OR UNPACKAGED

521.1. The concentrations included in the definitions of LSA material and SCOs in the 1973 edition of the Regulations were such that, if packaging were lost, allowed materials could produce radiation levels in excess of those deemed acceptable for Type A packages under accident conditions. Since industrial packages used for transporting LSA material and SCOs are not required to withstand transport accidents, a provision was initiated in the 1985 edition of the Regulations to limit package contents to the amount which would limit the external radiation level at 3 m from the unshielded material or object to 10 mSv/h. Geometrical changes of LSA material or SCOs as a result of an accident are not expected to lead to a significant increase of this external radiation level. This limits accident consequences associated with LSA material and SCOs to essentially the same level as that associated with Type A packages, where the A_1 value is based on the unshielded contents of a Type A package creating radiation levels of 100 mSv/h at a distance of 1 m.

521.2. In the case of solid radioactive waste essentially uniformly distributed in a concrete matrix placed inside a thick wall concrete packaging, the shielding of the concrete wall should not be considered as satisfying the condition of para. 521. However, the radiation level at 3 m from the unshielded concrete matrix may be assessed by direct measurement outside the thick wall of the concrete packaging and

then corrected to take into account the shielding effect of the concrete wall. This method can also be used in the case of other types of packaging.

523.1. According to paras 241(a)(iii) and 523(c), SCO-I is allowed to have non-fixed contamination on inaccessible surfaces in excess of the values specified in para. 241(a)(i). Items such as pipes deriving from the decommissioning of a facility should be prepared for unpackaged transport in a way to ensure that there is no release of radioactive material into the conveyance. This can be done, for example, by using end caps or plugs at both ends of the pipes (see also para. 241.7).

524.1. The higher the potential hazards of LSA materials and SCOs, the greater should be the integrity of the package. In assessing the potential hazards, the physical form of the LSA material has been taken into account.

524.2. See para. 226.1.

525.1. Conveyance activity limits for LSA materials and SCOs have been specified, the potential hazards having been taken into account, including the greater hazards presented by liquids and gases, combustible solids and contamination levels in the event of an accident.

525.2. 'Combustible solids' in Table V of the Regulations means all LSA-II and LSA-III materials in solid form which are capable of sustaining combustion either on their own or in a fire.

DETERMINATION OF TRANSPORT INDEX

526.1. The transport index (TI) is an indicator of the radiation level in the vicinity of a package, overpack, tank, freight container, conveyance, unpackaged LSA-I or unpackaged SCO-I and is used in the provision of radiation protection measures during transport. The value obtained for the TI in accordance with the following guidelines is required (see para. 526(c)) to be rounded up to the first decimal place (e.g. 1.13 becomes 1.2) except that a value of 0.05 or less may be considered as zero:

- (a) The TI for a package is the maximum radiation level at 1 m from the external surface of the package, expressed in mSv/h and multiplied by 100.
- (b) The TI for a rigid overpack, freight container or conveyance is either the maximum radiation level at 1 m from the external surface of the overpack or conveyance, expressed in mSv/h and multiplied by 100, or the sum of the TIs of all the packages contained in the overpack or conveyance.

- (c) The TI for a freight container, tank, unpackaged LSA-I or unpackaged SCO-I is the maximum radiation level at 1 m from the external surface of the load, expressed in mSv/h and multiplied by 100 and then further multiplied by an additional factor which depends on the largest cross-sectional area of the load. This additional multiplication factor, as specified in Table VI of the Regulations, ranges from 1 up to 10. It is equal to 1 if the largest cross-sectional area of the load is 1 m² or less. It is 10 if the largest cross-sectional area is more than 20 m². However, as noted previously, the TI for a freight container may be established alternatively as the sum of the TIs of all the packages in the freight container.
- (d) The TI for a non-rigid overpack shall be determined only as the sum of the TIs of all the packages in the non-rigid overpack.
- (e) The TI for loads of uranium and thorium ores and their concentrates can be determined without measuring the radiation levels. Instead, the maximum radiation level at any point 1 m from the external surface of such loads may be taken as the level specified in para. 526(a). The multiplication factor of 100 and the additional multiplication factor for the largest cross-sectional area of the load are still required, when applicable as indicated above, for determining the TI of such loads.

526.2. In the case of large dimension loads where the contents cannot be reasonably treated as a point source, radiation levels external to the loads do not decrease with distance as the inverse square law would indicate. Since the inverse square law formed the basis for the calculation of segregation distances, a mechanism was added for large dimension loads to compensate for the fact that radiation levels at distances from the load greater than 1 m would be higher than the inverse square law would indicate. The requirement of para. 526(b), which in turn imposes the multiplication factors in Table VI of the Regulations, provides the mechanism to make the assigned TI correspond to radiation levels at greater distances, for those circumstances felt to warrant it. These circumstances are restricted to the carriage of radioactive material in tanks or freight containers and the carriage of unpackaged LSA-I and SCO-I. The factors approximate to those appropriate to treating the loads as broad plane sources or three dimensional cylinders [27] rather than point sources, although actual radiation profiles are more complex owing to the influences of uneven self-shielding, source distribution and scatter.

526.3. The TI is determined by scanning all surfaces of a package, including the top and bottom, at a distance of 1 m. The highest value measured is the value that determines the TI. Similarly, the TI for a tank, a freight container and unpackaged LSA-I and SCO-I materials is determined by measuring at 1 m from the surfaces, but a multiplication factor according to the size of the load should be applied in order to define the TI. The size of the load will normally be taken as the maximum cross-sectional area of the tank, freight container or conveyance, but where its actual maximum area is known this may be used provided that it will not change during transport.

526.4. Where there are protrusions on the exterior surface, the protrusion should be ignored in determining the 1 m distance, except in the case of a finned package, in which case the measurement may be made at 1 m distance from the external envelope of the package.

527.1. For rigid overpacks, freight containers and conveyances, adding the TIs reflects a conservative approach as the sum of the TIs of the packages contained is expected to be higher than the TI obtained by measurement of the maximum radiation level at 1 m from the external surface of the overpack, freight container or conveyance due to shielding effects and additional distance with such measurement. In the case of non-rigid overpacks, the TI may only be determined as the sum of the TIs of all packages contained. This is necessary because the dimensions of the overpack are not fixed and radiation level measurements at different times may give rise to different results.

DETERMINATION OF CRITICALITY SAFETY INDEX

528.1. This paragraph establishes the procedure for obtaining the criticality safety index (CSI) of a package. The value of N used to determine the CSI must be such that a package array based on this value would be subcritical under the conditions of both paras 681 and 682. It would be wrong to assume that one condition would be satisfied if the other alone has been subjected to detailed analyses. The results of any one of the specified tests could cause a change in the packaging or contents that could affect the system moderation and/or the neutron interaction between packages, thus causing a distinct change in the neutron multiplication factor. Therefore, the limiting value of N cannot be assumed to be that of normal conditions or accident conditions prior to an assessment of both conditions.

528.2. To determine N values for arrays under normal conditions of transport (see para. 681) and under accident conditions of transport (see para. 682), tentative values for N may be used. Any array of five times N packages each under the conditions specified in para. 681(b) should be tested to see if it is subcritical, and any array of two times N packages each under the conditions in para. 682(b) should be tested to see if it is subcritical. If acceptable, N can be used for determining the CSI of the package. If the assessment indicates the selected N value does not yield a subcritical array under all required conditions, then N should be reduced and the assessments of paras 681 and 682 should be repeated to ensure subcriticality. Another, more thorough approach, is to determine the two N values that separately satisfy the requirements of paras 681 and 682, and then use the smaller of these two values to determine the value of the CSI. This latter approach is termed 'more thorough' because it provides a limiting assessment for each of the array conditions — normal and accident.

528.3. The CSI for a package, overpack or freight container should be rounded up to the first decimal place. For example, if the value of N is 11, then $50/N$ is 4.5454 and that value should be rounded up to provide a CSI = 4.6. The CSI should not be rounded down. To avoid disadvantages by this rounding procedure with the consequences that only a smaller number of packages can be transported (in the given example the number would be 10), the exact value of the CSI may be taken.

529.1. All packages containing fissile material, other than those excepted by para. 672, are assigned their appropriate CSI and should display the CSI value in the label as shown in Fig. 5 of the Regulations. The consignor should be careful to confirm that the CSI for each consignment is identical to the sum of the CSI values provided on the package labels.

LIMITS ON TRANSPORT INDEX, CRITICALITY SAFETY INDEX AND RADIATION LEVELS FOR PACKAGES AND OVERPACKS

530.1. In order to comply with the general requirements for nuclear criticality control and radiation protection, limits are set for the maximum TI, the maximum CSI and the maximum external surface radiation level for packages and overpacks (see also paras 531 and 532). In the case of transport under exclusive use, these limits may be exceeded because of the additional operational controls (see also paras 221.1–221.6).

531.1. See para. 530.1.

532.1. See para. 530.1.

532.2. Even though a package is permitted to have an external radiation level up to 10 mSv/h, the requirements for a maximum dose limit of 2 mSv/h on the surface of the conveyance or of 0.1 mSv/h at any point 2 m from the surface of the conveyance (see para. 566) may be more limiting in certain instances. See also para. 233.2 regarding the buildup of daughter nuclides in transport.

CATEGORIES

533.1. All packages, overpacks, freight containers and tanks other than those consisting entirely of excepted packages must be assigned a category. This is a necessary prerequisite to labelling and placarding.

533.2. Packages, overpacks, freight containers and tanks other than those consisting entirely of excepted packages must be assigned to one of the categories I-WHITE, II-YELLOW or III-YELLOW to assist in handling and stowage. The applicable category is determined by the TI and the radiation level at any point on the external surface of the package or overpack. In certain cases the package TI or surface radiation level may be in excess of what would normally be allowed for packages or overpacks in the highest category, i.e. III-YELLOW. In such cases the Regulations require that the consignment be transported under exclusive use conditions.

533.3. The radiation level limits inherent in the definition of the categories have been derived on the basis of assumed package/cargo handling procedures, exposure times for transport workers and exposure times for photographic film. Historically these were derived as follows [28]:

- (a) 0.005 mSv/h at surface — This surface limit was derived, not from consideration of radiation effects on persons, but from the more limiting effect on undeveloped photographic film. Evaluation of the effect of radiation on sensitive X ray film in 1947 showed that threshold fogging would occur at an exposure of 0.15 mSv, and a limit was set in the 1961 edition of the Regulations of 0.1 mSv linked to a nominal maximum exposure time of 24 h. In later editions of the Regulations (1964, 1967, 1973 and 1973 (as amended)), the 24 h period was rounded to 20 h and the limiting dose rate of 0.005 mSv/h was taken as a rounded-down value to provide protection to undeveloped film for such periods of transport. This dose rate was applied as a surface limit for category I-WHITE packages, which would ensure there being little likelihood of radiation damage to film or unacceptable doses to transport personnel, without need for segregation requirements.
- (b) 0.1 mSv/h at 1 m — For the purposes of limiting the radiation dose to film and to persons, the dose of 0.1 mSv discussed in (a) above was combined with the exposure rate at 1 m from the package and an exposure time of 1 h to give the 10 times TI limitation of the 1964, 1967 and 1973 editions of the Regulations (10 ‘radiation units’ in the 1961 edition). This was based upon an assumed transit time of 24 h and the conventional separation distance of 4.5 m (15 feet) between parcels containing radium in use by the US Railway Express Company in 1947. The above limitation would yield a dose of approximately 0.1 mSv at 4.5 m (15 feet) in 24 h.
- (c) 2.0 mSv/h at surface — A separate limit of 2.0 mSv/h at the surface was applied in addition to the limit explained in (b) above on the basis that a transport worker carrying such packages for 30 min a day, held close to the body, would not exceed the then permissible dose of 1 mSv per 8 h working day.

While such doses would no longer be acceptable, the adequacy of the current radiation level limits, in terms of radiological safety, has been confirmed by a number of surveys where radiation exposure of transport workers has been determined [29–32] and by an assessment performed by the IAEA in 1985 [33]. However, it is recognized that the permitted radiation levels around packages and conveyances do not alone ensure acceptably low doses, and the Regulations also require the establishment of radiation protection programmes (para. 301) and the periodic assessment of radiation doses to persons due to the transport of radioactive material (para. 304).

MARKING, LABELLING AND PLACARDING

Marking

534.1. To retain the possibility of identifying the consignee or consignor of a package for which normal control is lost (e.g. lost in transit or misplaced), an identification marking is required on the package. This marking may consist of the name or address of either the consignor or consignee, or may be a number identifying a way-bill or transport document which contains this information.

534.2. See also paras 536.2–536.6 for general advice on compliance with the requirement for the marking to be legible and durable.

535.1. The United Nations numbers, each of which is associated with a unique proper shipping name, have the function of identifying dangerous goods, either as specifically named substances or in generic groups of consignments. The UN numbers for radioactive material were agreed through joint international co-operation between the United Nations Committee of Experts on the Transport of Dangerous Goods and the IAEA. The system of identification by means of numbers is preferable to other forms of identification using symbols or language due to their relative simplicity in terms of international recognition. This identification can be used for many purposes. UN numbers which are harmonized with other dangerous goods permit rapid and appropriate identification of radioactive goods within the broader transport environment of dangerous goods in general. Another example is the use of the UN numbers as a unique identification for emergency response operations. Each UN number can be associated with a unique emergency response advice table which permits first responders to refer to general advice in the unavoidable absence of a specialist. During the first stages of an emergency, this prepared information can be more easily accessible to a wide group of non-specialist emergency responders (see also paras 547.1 and 549.1–549.5).

535.2. UN numbers for radioactive material are now used to relate requirements in the Schedules to the Regulations. This has proven to be an advantage in terms of identifying the requirements applicable to specific package or material types. UN numbers can also be used for compliance situations, performance checks and controls, data collection and other statistical purposes, should the competent authority find merit in this application.

535.3. See also paras 536.2–536.6 for general advice on compliance with the requirement for the marking to be legible and durable.

536.1. Packages exceeding 50 kg gross mass are likely to be handled by mechanical rather than manual means and require marking of the gross mass to indicate the possible need for mechanical handling and observance of floor loading and vehicle loading limits. In practice, however, even packages having a gross mass of up to 50 kg should not regularly be handled manually. Before packages are handled manually on a regular basis, a procedure should be available to ensure that the radiological consequences are as low as reasonably achievable (see para. 301). Mechanical means should be used wherever practicable. To be useful in this respect, the marking is required to be legible and durable.

536.2. Markings on packages should be boldly printed, of sufficient size and sensibly located to be legible, bearing in mind the likely handling means to be employed. A character height of 12.5 mm should be considered a suitable minimum for light-weight packages (i.e. up to a few hundred kilograms) where close contact by mechanical means, e.g. forklift trucks, is likely to be used. Heavier packages will require more ‘remote’ handling methods, and the character size should be increased accordingly to allow operators to read the markings at a distance. A size of 65 mm is considered to be sufficient for the largest packages of tens of tonnes to the hundred tonne range. To ensure legibility, a contrasting background should be applied before marking if the external finish of the package does not already provide a sufficient contrast. Black characters on a white background are suitable. Where packages have irregular outer surfaces (e.g. fins or corrugations) or surfaces unsuitable for direct application of the markings, it may be necessary to provide a flat board or plate on which to place the markings to enhance legibility.

536.3. Markings should be durable in the sense of being at least resistant to the rigours of normal transport, including the effects of open weather exposure and abrasion, without substantial reduction in effectiveness. Attention is drawn to the need to consult national and modal transport regulations which may contain stricter requirements. For example, the International Maritime Dangerous Goods (IMDG) Code [10] requires all permanent markings (and also labels) to remain identifiable on packages surviving immersion in the sea for at least three months. When a board or

plate is used to bear a marking, it should be fitted securely to the package in a manner consistent with the integrity standard of the package itself.

536.4. The means of marking will depend on the nature of the external surface of the packaging itself, ranging (in order of durability) from a printed label (for the name of the consignee or consignor, UN number and proper shipping name or the gross mass), stencilling or soft stamping with indelible inks or paints (suitable for fibreboard or wooden packagings), through branding (for wooden packagings), painting with enamel or resin based paints (suitable for many surfaces, particularly metals), to hard stamping, embossing or ‘cast-in’ markings of metallic outer packagings.

536.5. Appropriate national and modal transport regulations should always be consulted to supplement the general advice in paras 536.2–536.4, as variations in detailed requirements may be considerable.

536.6. The scheduled inspection and maintenance programme required for packagings should include provisions to inspect all permanent markings and to repair any damage or defects. Experience from such inspections will indicate whether durability has been achieved in practice.

537.1. The 1996 edition of the Regulations introduces the requirement to identify Industrial packages with a mark. The design of the mark is consistent with other similar marks in that it includes the word ‘Type’ together with the appropriate Industrial package description (e.g. Type IP-2). The design of the mark also avoids potential confusion where, in other transport regulations, the abbreviation IP may be used for a different purpose. For example, the ICAO Technical Instructions use IP to mean Inner Packaging, e.g. ‘IP.3’ to denote one out of ten particular kinds of inner packaging.

537.2. Although no competent authority approval is required for Industrial packages whose contents are not fissile material, the designer and/or consignor should be in a position to demonstrate compliance to any cognizant competent authority. This marking assists in the inspection and enforcement activities of the competent authorities. The marking would also provide, to the knowledgeable observer, valuable information in the event of an accident.

537.3. See also paras 536.2–536.6 for general advice on compliance with the requirement for the marking to be legible and durable.

538.1. All Type B(U), Type B(M), Type C and fissile material package designs require competent authority approval. Markings on such packages aim at providing a link between the individual package and the corresponding national competent

authority design approval (via the identification mark), as well as information on the kind of competent authority design approval. Furthermore, the marking of the package provides, to the knowledgeable observer, valuable information in the event of an accident. In the case of package designs for uranium hexafluoride, the requirement for packages to bear a competent authority identification mark as provided in para. 828(c) depends upon the entry into force of requirements to receive competent authority approval, the due dates for which are given in para. 805.

538.2. The marking with a serial number is required because operational quality assurance and maintenance activities are oriented towards each packaging and the corresponding need to perform and verify these activities on an individual packaging basis. The serial number is also necessary for the competent authority's compliance assurance activities and for application of paras 815–817.

538.3. General advice on legibility, durability of markings and inspection/maintenance of markings is given in paras 536.2–536.4. However, where possible the competent authority identification mark, serial number and Type B(U), Type B(M) or Type C mark should be resistant to being rendered illegible, obliterated or removed even under accident conditions. It may be convenient to apply such markings adjacent to the trefoil symbol on the external surface of the package (see para. 539 and Fig. 1 of the Regulations). For example, an embossed metal plate may be used to combine these markings.

538.4. An approved package design may be such that different internal components can be used with a single outermost component, or the internal components of the packaging may be interchangeable between more than one outermost component. In these cases, each outermost component of the packaging with a unique serial number will identify the packaging as an assembly of components which satisfies the requirements of para. 538(b), provided that the assembly of components is in accordance with the design approved by the competent authorities. In such cases, the quality assurance programme established by the consignor should ensure the correct identification and use of these components.

539.1. The marking of a Type B(U), Type B(M) or Type C package with a trefoil symbol resistant to the effects of fire and water is intended to ensure that such a type of package can be positively identified after a severe accident as carrying radioactive material.

540.1. LSA-I materials and SCO-I may be transported unpackaged under the specifications given in para. 523. One of the conditions specified sets out to ensure that there will be no loss of contents during normal conditions of transport. Depending on

the characteristics of the material, wrapping or similar measures may be suitable to satisfy this requirement. Wrapping may also be advantageous from a practical point of view, for example to be able to affix a label to carry information of interest to the consignee or consignor. In situations where it is desirable to clearly identify the consignment as carrying radioactive material, the Regulations explicitly allow such an identifier to be placed on the wrapping or receptacle. It is important to note that the Regulations do not require such marking; the option is, however, made available for application where it is considered useful.

Labelling

541.1. Packages, overpacks, tanks and freight containers can be characterized as handling or cargo units. Transport workers need to be made aware of the contents when such units carry radioactive materials and need to know that potential radiological and criticality hazards exist. The labels provide that information by the trefoil symbol, the colour and the category (I-WHITE, II-YELLOW or III-YELLOW), and the fissile label. Through the labels it is possible to identify (a) the radiological or criticality hazards associated with the radioactive content of the cargo unit and (b) the storage and stowage provisions which may be applicable to such units.

541.2. The radioactive material labels used form part of a set of labels used internationally to identify the various classes of dangerous goods. This set of labels has been established with the aim of making dangerous goods easily recognizable from a distance by means of symbols. The specific symbol chosen to identify cargo units carrying radioactive material is the trefoil.

541.3. The content of a cargo unit may, in addition to its radioactive properties, also be dangerous in other respects, e.g. corrosive or flammable. In these cases the regulations pertaining to this additional hazard must be adhered to. This means that, in addition to the radioactive material label, other relevant labels need to be displayed on the cargo unit.

542.1. For tanks or freight containers, because of the chance that the container could be obscured by other freight containers and tanks, the labels need to be displayed on all four sides in order to ensure that a label is visible without having to be searched for, and to minimize the chance of its being obscured by other units or cargo.

Labelling for radioactive contents

543.1. In addition to identifying the radioactive properties of the contents, the labels also carry more specific information regarding the contents, i.e. the name of the

nuclide, or the most restrictive nuclides in the case of a mixture of radionuclides, and the activity. In the case of fissile contents, the mass of fissile material may be substituted for the activity. This information is important in the event of an incident or accident where content information may be needed to evaluate the hazard. The more specific information regarding the contents is not required for LSA-I material, because of the low radiation hazard associated with such material.

543.2. Yellow labels also show the TI of the cargo unit (i.e. package, overpack, tank and freight container). The TI information is essential in terms of storage and stowage in that it is used to control the accumulation and assure proper separation of cargo units. The Regulations prescribe limits on the total sum of TIs in such groups of cargo units (see Table IX of the Regulations, for transport not under exclusive use).

543.3. In the identification of the most restrictive radionuclides for the purpose of identifying a mixture of radionuclides on a label, consideration should be given not only to the lowest A_1 or A_2 values, but also to the relative quantities of radionuclides involved. For example, a way to identify the most restrictive radionuclide is by determining for the various radionuclides the value of

$$\frac{f_i}{A_i}$$

where

f_i is the activity of radionuclide i , and
 $A_i = A_1$ or A_2 for radionuclide i , as applicable.

The highest value represents the most restrictive radionuclide.

Labelling for criticality safety

544.1. The criticality safety index (CSI) is a number used to identify the control needed for criticality safety purposes. The control is provided by limiting the sum of the CSIs to 50 for shipments not under exclusive use and to 100 for shipments under exclusive use.

544.2. The labels carrying the CSI should appear on packages containing fissile material, as required by para. 541. The CSI label is additional to the category labels (Categories I-WHITE, II-YELLOW and III-YELLOW), because its purpose is to provide information on the CSI, whereas the category label provides information on

the transport index (TI) and the contents. The CSI label, in its own right, also identifies the package as containing fissile material.

544.3. Like the TI, the CSI provides essential information relevant to storage and stowage arrangements in that it is used to control the accumulation and assure proper separation of cargo units with fissile material contents. The Regulations prescribe limits on the total sum of CSIs in such groups of cargo units (see Table X of the Regulations for both transport under and not under exclusive use).

545.1. See paras 544.1–544.3.

Placarding

546.1. Placards, which are used on large freight containers and tanks (and also on road and rail vehicles; see para. 570) are designed in a way similar to the package labels (although they do not bear the detailed information of TI, contents and activity) in order to clearly identify the hazards of the dangerous goods. Displaying the placards on all four sides of the freight containers and tanks ensures ready recognition from all directions. The size of the placard is intended to make it easy to read, even at a distance. To prevent the need for an excessive number of placards and labels, an enlarged label only may be used on large freight containers and tanks, where the enlarged label also serves the function of a placard.

547.1. The display of the UN number can provide information on the type of radioactive material transported, including whether or not it is fissile, and information on the package type. This information is important in the case of incidents or accidents resulting in leakage of the radioactive material in that it assists those responsible for emergency response to determine proper response actions (see para. 535.1).

CONSIGNOR'S RESPONSIBILITIES

Particulars of consignment

549.1. The list of information provided by the consignor in complying with para. 549 is intended to inform the carrier and the consignee as well as other parties concerned of the exact nature of a consignment so that all appropriate actions may be taken. In providing this information, the consignor is also, incidentally, reminded of the regulatory requirements applicable to the consignment throughout its preparation for transport and on despatch (see also para. 535.1).

549.2. A list of the proper shipping names and the corresponding UN numbers is included in Table VIII of the Regulations.

549.3. The attention of the consignor is drawn to the particular requirement of para. 549(k) regarding consignments of packages in an overpack or freight container. Each package or collection of packages is required to have appropriate documentation. This is important in regard to the 'Consignor's declaration'. Nobody other than the consignor can make this declaration and so he or she is required to assure that appropriate documents are prepared for all parts of a mixed consignment so that they can continue their journey after being removed from an overpack or freight container.

549.4. Care should be exercised in selecting the proper shipping name from Table VIII of the Regulations. Portions of an entry that are not highlighted by capital letters are not considered part of the proper shipping name. When the proper shipping name contains the conjunction 'or', only one of the possible alternatives should be used. The following examples illustrate the selection of proper shipping names of the entry for UN Nos 2909, 2915 and 3332:

UN No. 2909 RADIOACTIVE MATERIAL, EXCEPTED PACKAGE —
ARTICLES MANUFACTURED FROM NATURAL URANIUM or
DEPLETED URANIUM or NATURAL THORIUM

The proper shipping name is the applicable description from the following:

UN No. 2909 RADIOACTIVE MATERIAL, EXCEPTED PACKAGE —
ARTICLES MANUFACTURED FROM NATURAL URANIUM

UN No. 2909 RADIOACTIVE MATERIAL, EXCEPTED PACKAGE —
ARTICLES MANUFACTURED FROM DEPLETED URANIUM

UN No. 2909 RADIOACTIVE MATERIAL, EXCEPTED PACKAGE —
ARTICLES MANUFACTURED FROM NATURAL THORIUM

UN No. 2915 RADIOACTIVE MATERIAL, TYPE A PACKAGE, non-special form,
non-fissile or fissile-excepted

UN No. 3332 RADIOACTIVE MATERIAL, TYPE A PACKAGE, SPECIAL FORM,
non-fissile or fissile-excepted

The proper shipping name is the applicable description from the following:

UN No. 2915 RADIOACTIVE MATERIAL, TYPE A PACKAGE

UN No. 3332 RADIOACTIVE MATERIAL, TYPE A PACKAGE, SPECIAL FORM

As can be seen from the example UN No. 3332, the added characteristic (here Special Form) is explicitly spelled out.

549.5. Another example related to the interpretation and use of the UN number concept relates to empty packagings which have contained radioactive material, i.e. UN No. 2908. If there are residues or 'heels' in the packaging, e.g. in UF₆ packages, the packaging should not be called 'empty packaging' but should be shipped as a package (i.e. not as a packaging). The quantity remaining would determine the package category (see also para. 520.4).

549.6. The maximum activity of the contents during transport is required to be specified in the transport documents (para. 549(f)). In some cases the activity may increase as a result of the buildup of daughter nuclides during transport. In such cases a proper correction should be applied in order to determine the maximum activity.

549.7. Advice on the identification of the most restrictive nuclides is given in para. 543.3. Appropriate general descriptions may include, when relevant, irradiated (or spent) nuclear fuel or specified types of radioactive waste.

549.8. It is necessary for LSA-II and LSA-III materials and for SCO-I and SCO-II to indicate the total activity as a multiple of A₂. For SCO-I and SCO-II the activity should be calculated from the surface contamination and the area. In the case that the nuclide cannot be identified, the lowest A₂ value among the possible alpha nuclides and the beta-gamma nuclides should be used for the calculation of the total activity.

Removal or covering of labels

554.1. The purpose of labels is to provide information on the current package contents. Any previously displayed label could give the wrong information.

Possession of certificates and instructions

561.1. As well as having a copy of the package approval certificate in his possession, the consignor is required to ensure that he has the necessary instructions for properly closing and preparing the package for transport. In some countries it may be necessary for the consignor to register as a user of that certificate with the appropriate competent authority.

TRANSPORT AND STORAGE IN TRANSIT

Segregation during transport and storage in transit

562.1. Specific attention has been drawn to the need for segregation in transport and storage in transit to ensure that radiation exposures to persons and undeveloped photographic film remain in accordance with the principles of paras 306 and 307. Section V deals with controls during transport, and in this context it is necessary to take specific steps to ensure that the principles are translated into requirements with which carriers can easily comply. The Regulations do not specifically do this since the conditions of carriage are very dependent on the mode of transport; the international transport organizations are in a better position to prescribe specific requirements and to reach the appropriate audience.

562.2. In order to implement the requirements for radiation protection contained in paras 301–307, simple procedures have been developed which will suitably limit radiation exposures to both persons and undeveloped film.

562.3. An effective way of limiting exposures to persons during transport is to require appropriate segregation distances between the radioactive material and the areas where people may be present. The Regulations provide the basis for the determination of segregation requirements but the actual determination and specification of these requirements is done at the modal level. Segregation distance requirements are prescribed by national regulatory bodies and international transport organizations such as the International Civil Aviation Organization (ICAO) [12] and the International Maritime Organization (IMO) [10]. They have been derived on the basis of radiological models and confirmed by experience: actual doses arising from the use of these distances in the air and sea mode have been very much lower than the limiting values of dose originally used in the models which derived them. In addition, in the requirements of ICAO [12] and IATA [14] care should be taken with State, airline and operator variations, which may be more restrictive than the provisions contained in the IAEA Regulations.

562.4. There are many considerations and conditions specific to the transport mode which should be factored into the models used to calculate segregation distances. These include consideration of how the relationship between accumulated transport indices in a location and radiation levels in occupied areas is affected by shielding and distance, and how exposure times for workers and members of the public depend upon the frequency and duration of their travel in conjunction with radioactive material. These may be established by programmes of work using questionnaires, surveys and measurements. In some circumstances exposure for a short

time close to packages, for example during inspection or maintenance work on sea voyages, can be more important than longer exposure times at lower dose rates in more regularly occupied areas. An example of the use of a model for determining minimum segregation and spacing distances for passenger and cargo aircraft is given in Appendix III.

562.5. Inevitably such calculations will be based on assumptions which may differ from real parameters in particular circumstances. Models should be robust and conservative. However, those that use all ‘worst case’ parameters may result in recommendations leading to unnecessary practical difficulties or financial penalties. That the application of the resulting segregation distances leads to acceptably low doses is more important than the basis on which the distances were calculated. However, transport patterns are subject to change and doses should be kept under review.

562.6. The virtues of simplicity should not be ignored. Clear and simple requirements are more easily, and more likely to be followed, than complex, more rigorous ones. The simplified segregation table in the IMDG Code [10] giving practical segregation distances for different vessel types and the translation of the segregation distances of ICAO’s Technical Instructions [12] by operators into TI limits per hold are good examples of this.

562.7. When calculating segregation distances for storage transit areas, the TI of the packages and the maximum time of occupancy should be considered. If there is any doubt regarding the effectiveness of the distance, a check may be made using appropriate instruments for the measurement of radiation levels.

562.8. If different classes of dangerous goods are being transported together, there is a possibility that the contents of leaking packages may affect adjacent cargo, e.g. a leak of corrosive material could reduce the effectiveness of the containment system for a package of radioactive material. Thus, in some cases it has been found necessary to restrict the classes of dangerous goods that may be transported near other classes. In some cases it may simply be stated which classes of dangerous goods must be segregated from others. In order to provide a complete and easy procedure for understanding the requirements, it has been found that presentation of this information in a concise tabular form is useful. As an example of a segregation table, the one included in Part 7 of the IMDG Code [10] is given here as Table II.

562.9. Since mail bags often contain undeveloped film and will not be identified as such, it is prudent to protect mail bags in the same way as identified undeveloped film.

Stowage during transport and storage in transit

564.1. The retention of packages within or on conveyances is required for several reasons. By virtue of the movement of the conveyance during transport, small packages may be thrown or may tumble within or on their conveyances if not retained, resulting in their being damaged. Packages may also be dropped from the conveyance, resulting in their loss or damage. Heavy packages may shift position within or on a conveyance if not properly secured, which could make the conveyance unstable and could thereby cause an accident. Packages should also be restrained to avoid their movement in order to ensure that the radiation dose rate on the outside of the conveyance, to the driver or to the crew, is not increased.

564.2. Within the context of the Regulations, 'stowage' means the locating, within or on a conveyance, of a package containing radioactive material relative to other cargo (both radioactive and non-radioactive), and 'retention' means the use of dunnage, braces, blocks or tie-downs, as appropriate, to restrain the package, preventing movement within or on a conveyance during routine transport. When a freight container is used either to facilitate the transport of packaged radioactive material or to act as an overpack, provisions should be made for the packages to be restrained within the freight container. Methods of retention, e.g. lashings, throw-over nets or compartmentation, should be used to prevent damage to the packages when the freight container is being handled or transported.

564.3. For additional guidance on the methods of retention, see Appendix V.

565.1. Some Type B(U), Type B(M) and Type C packages of radioactive material may give off heat. This is a result of radiation energy being absorbed in the components of the package as heat which is transferred to the surface of the package and thence to the ambient air. In such cases, heat dissipation capability is designed into the package and represents a safe and normal condition. For example, Co-60 produces approximately 15 W per 40 TBq. Since most of this is absorbed in the shielding of the package, the total heat load can be of the order of thousands of watts. The problem can be compounded if there are several similar packages in the shipment. As well as paying attention to the materials next to the packages, care should be taken to ensure that the air circulation in any compartment containing the packages is not overly restricted so as not to cause a significant increase in the ambient temperature immediately in the area of the packages. Carriers must be careful not to reduce the heat dissipation capability of the package(s) by covering the package(s) or overstowing or close-packing with other cargo which may act as thermal insulation. When packages of radioactive materials give off significant heat, the consignor is required to provide the carrier with instructions on the proper stowage of the package (see para. 555).

TABLE II. SAMPLE SEGREGATION BETWEEN CLASSES OF DANGEROUS GOODS
(Taken from the IMDG-Code [10])

CLASS	1.1 1.2 1.5	1.3 1.6	1.4	2.1	2.2	2.3	3	4.1	4.2	4.3	5.1	5.2	6.1	6.2	7	8	9	
Explosives	1.1, 1.2, 1.5	*	*	*	4	2	2	4	4	4	4	4	4	2	4	2	4	X
Explosives	1.3, 1.6	*	*	*	4	2	2	4	3	3	4	4	4	2	4	2	2	X
Explosives	1.4	*	*	*	2	1	1	2	2	2	2	2	2	X	4	2	2	X
Flammable gases	2.1	4	4	2	X	X	X	2	1	2	X	2	2	X	4	2	1	X
Non-toxic, non-flammable gases	2.2	2	2	1	X	X	X	1	X	1	X	X	1	X	2	1	X	X
Toxic gases	2.3	2	2	1	X	X	X	2	X	2	X	X	2	X	2	1	X	X
Flammable liquids	3	4	4	2	2	1	2	X	X	2	1	2	2	X	3	2	X	X
Flammable solids (including self-reactive and related substances and desensitized explosives)	4.1	4	3	2	1	X	X	X	X	1	X	1	2	X	3	2	1	X
Substances liable to spontaneous combustion	4.2	4	3	2	2	1	2	2	1	X	1	2	2	1	3	2	1	X

TABLE II. (cont.)

CLASS	1.1	1.3	1.4	2.1	2.2	2.3	3	4.1	4.2	4.3	5.1	5.2	6.1	6.2	7	8	9	
	1.2	1.6																
	1.5																	
Substances which, in contact with water, emit flammable gases	4.3	4	4	2	X	X	X	1	X	1	X	2	2	X	2	2	1	X
Oxidizing substances (agents)	5.1	4	4	2	2	X	X	2	1	2	2	X	2	1	3	1	2	X
Organic peroxides	5.2	4	4	2	2	1	2	2	2	2	2	X	1	3	2	2	2	X
Toxic substances	6.1	2	2	X	X	X	X	X	X	1	X	1	1	X	1	X	X	X
Infectious substances	6.2	4	4	4	4	2	2	3	3	3	2	3	3	1	X	3	3	X
Radioactive material	7	2	2	2	2	1	1	2	2	2	2	1	2	X	3	X	2	X
Corrosive substances	8	4	2	2	1	X	X	X	1	1	1	2	2	X	3	2	X	X
Miscellaneous dangerous substances and articles	9	X	X	X	X	X	X	X	X	X	X	X	X	X	X	X	X	X

Numbers and symbols relate to the following terms as defined in Chapter 7 of the IMDG Code:

1 – “Away from”

2 – “Separated from”

3 – “Separated by a complete compartment or hold from”

4 – “Separated longitudinally by an intervening complete compartment or hold from”

X – The segregation, if any, is shown in the Dangerous Goods List of the IMDG Code.

* – See Subsection 7.2.7.2 of the IMDG Code.

565.2. Studies have shown that if the rate of generation of heat within a package is small (corresponding to a surface heat flux of less than 15 W/m^2), the heat can be dissipated by conduction alone and the temperature will not exceed 50°C even if the package is completely surrounded by bulk loose cargo. The air gaps between packages allow sufficient dissipation to occur by air convection.

566.1. There are two primary reasons for limiting the accumulation of packages in groups, or in conveyances and freight containers. When packages are placed in close proximity, control must be exercised:

- (a) To prevent the creation of higher than acceptable radiation levels as a result of the additive effects of radiation from the individual packages. For consignments not carried under exclusive use, this is done by placing a limit on the total number of TIs. The theoretical maximum dose rate at 2 m from the surface of a vehicle carrying 50 TIs was historically calculated as 0.125 mSv/h , and considered to be equivalent to 0.1 mSv/h since the maximum was unlikely to be reached. Experience has confirmed the acceptability of these values.
- (b) To prevent nuclear criticality by limiting neutron interaction between packages containing fissile material. Restriction of the sum of the CSIs to 50 in any one group of packages (100 under exclusive use) and the 6 m spacing between groups of packages provide this assurance.

566.2. It should be noted that for the transport of a freight container there may be more than one entry in Table IX or Table X of the Regulations, respectively, that may be applicable. As an example, for a large freight container to be carried on a seagoing vessel there is no limit on the number of TIs or CSIs as regards the total vessel, whereas there is a limitation of TIs and CSIs in any one hold, compartment or defined deck area. It is also important to note that several requirements presented in the footnotes apply to certain shipments. These footnotes are requirements and not just information.

567.1. Any consignment with a CSI greater than 50 is also required to be transported under exclusive use (see para. 530.1). The loading arrangement assumed in the criticality assessment of paras 681 and 682 consists of an arrangement of identical packages. A study by Mennerdahl [34] provides a discussion of theoretical packaging arrangements that mix the package designs within the array and indicate the possibility for an increase in the neutron multiplication factor in comparison with an arrangement of identical packages. Although such arrangements are unlikely in practice, care should be taken in establishing the loading arrangement for shipments where the CSI exceeds 50. Attention should also be paid to assuring that packages of mixed design are properly arranged to maintain a safe configuration [35]. Where the CSI for a shipment exceeds 50, there is also a requirement to obtain a shipment approval (see para. 820).

Segregation of packages containing fissile material during transport and storage in transit

568.1. The requirement to maintain a spacing of 6 m is necessary for nuclear criticality control. Where two storage areas are divided by a wall, floor or similar boundary, storage of the packages on opposite sides of the separating physical boundary has still to meet the requirement for 6 m segregation.

569.1. See para. 568.1.

Additional requirements relating to transport by rail and by road

570.1. See paras 546.1 and 547.1.

570.2. Vehicles qualifying for the reduced size of placard would normally be of less than a permissible gross mass of 3500 kg.

571.1. See para. 547.1.

572.1. See paras 221.1–221.6 on exclusive use.

572.2. In most cases the radiation level at any point on the external surface of a package is limited to 2 mSv/h. For road and rail transport, when transported under exclusive use, packages and overpacks are allowed to exceed 2 mSv/h if access to the enclosed areas in the vehicle is restricted. Restriction of access to these areas may be achieved by using an enclosed vehicle that can be locked, or by bolting and locking a cage over the package. In some cases the open top of a vehicle with side walls may be covered with a tarpaulin, but this type of enclosure would generally not be considered adequate for preventing access.

572.3. During transit there should be no unloading or entering into the enclosed area of a vehicle. If the vehicle is being held in the carrier's compound for any period it should be parked in an area where access is controlled and where people are not likely to remain in close proximity for an extended period. If maintenance work is required to be done on the vehicle for an extended period, then arrangements should be made with the consignor or the consignee to ensure adequate radiation protection, e.g., by providing extra shielding and radiation monitoring.

572.4. It is essential to secure a package or overpack to prevent movement during transport which could cause the radiation level to exceed relevant limits or to increase the dose to the vehicle driver. For road transport a package or overpack

should be secured for forces resulting from acceleration, braking and turning as expected during normal conditions of transport. For rail transport, packages should also be secured to prevent movement during ‘humping’ of the rail car (see paras 564.1–564.3).

572.5. In establishing the dose rate for a conveyance, account may be taken of additional shielding within the conveyance. However, the integrity of the shielding should be maintained during routine transport; otherwise compliance with the conveyance radiation limit may not be maintained.

572.6. While it is a condition of para. 572(a)(iii) of the Regulations for exclusive use shipments that there must be no loading or unloading during the shipment, this does not preclude a carrier who is consolidating consignments from more than one source to assume the role and responsibility of the consignor for a combined consignment and being so designated for the purpose of the subsequent exclusive use shipment.

573.1. The restrictions as to who may be permitted to be present in vehicles carrying radioactive packages with significant radiation levels are to prevent unnecessary or uncontrolled exposures of persons.

573.2. The term ‘assistants’ should be interpreted as meaning any worker, being subject to the requirements of para. 305, whose business in the vehicle concerns either the vehicle itself or the radioactive consignment. It could not, for example, include any members of the public or passengers in the sense of those whose sole purpose in the vehicle is to travel. It could, however, include an inspector or health physics monitor in the course of his or her duties.

573.3. Vehicles should be loaded in such a way that the radiation level in occupied positions is minimized. This may be achieved by placing packages with higher radiation levels furthest away from the occupied area and placing heavy packages with low radiation levels nearer to the occupied position. During loading and unloading, direct handling times should be minimized and the use of handling devices such as nets or pallets should be considered in order to increase the distance of packages from the body. Personnel should be prevented from lingering in areas where significant radiation levels exist.

573.4. There was a provision concerning the radiation level at any normally occupied position in the case of road vehicles in the 1985 edition of the Regulations. This provision was deleted in the 1996 edition of the Regulations. It has effectively been superseded by the introduction of the concept of radiation protection programmes (see paras 301 and 305).

Additional requirements relating to transport by vessels

574.1. Each mode of transport has its own unique features. In the case of transport by sea the possibility of journey times of weeks or months and the need for continued routine inspection throughout the journey might lead to significant exposures during the carriage of the radioactive material. Simply having the exclusive use of a hold, compartment or defined deck area, particularly the latter, was not felt to provide sufficient radiological control for high radiation level packages. Two further restrictions were therefore introduced for packages having a surface radiation level greater than 2 mSv/h: either they must be in (or on) a vehicle or they must be transported under special arrangement. Access and radiation levels are therefore controlled by the provisions of para. 572 for vehicles or by controls relevant to particular circumstances prescribed by the competent authority under the terms of the special arrangement.

574.2. Transport by sea of any package having a surface radiation level exceeding 2 mSv/h is required to be done under special arrangement conditions, except when transported in or on a vehicle under exclusive use and when subject to the conditions of para. 572. However, if the latter situation occurs, it may be desirable for purposes of radiation protection that a specific area be allocated for that vehicle by the master of the ship or the competent authority concerned. This would be appropriate in particular for the transport of such vehicles aboard roll-on/roll-off ships such as ferries. Further guidance will be found in the IMDG Code [10].

575.1. The simple controls on the accumulation of packages as a means of limiting radiation exposure (para. 566) may not be appropriate for ships dedicated to the transport of radioactive material. Since the vessel itself may be transporting consignments from more than one consignor, it could not be considered as being under exclusive use, and the requirements of Tables IX and X of the Regulations might therefore be unnecessarily restrictive.

575.2. Special use vessels employed for the transport by sea of radioactive material have been adapted and/or dedicated specifically for that purpose. The required radiation protection programme should be based upon preplanned stowage arrangements specific to the vessel in question and to the number and the nature of the packages to be carried. The radiation protection programme should take into account the nature and intensity of the radiation likely to be emitted by packages; occupancy factors based on the planned maximum duration of voyages should also be taken into account. This information should be used to define stowage locations in relation to regularly occupied working spaces and living accommodation, in order to ensure adequate radiological protection of persons. The competent authority, normally the competent authority of the flag State of the vessel, may specify the

maximum number of packages permitted, their identity and contents, the precise stowage arrangements to be observed and the maximum radiation levels permitted at key locations. The radiation protection programme would normally require that appropriate monitoring be carried out during and after completion of stowage as necessary to ensure that specified doses or dose rates are not exceeded. Details of the results of such surveys, including any checks for contamination of packages and of cargo spaces, should be provided to the competent authority on request.

575.3. For packages containing fissile material, the programme should also take appropriate account of the need for nuclear criticality control.

575.4. Although not directly part of a radiation protection programme, limitations on stowage associated with the heat output from each package should be considered. The means for heat removal, both natural and mechanical, should be assessed for this purpose, and heat outputs for individual packages should be specified if necessary.

575.5. Records of measurements taken during each voyage should be supplied to the competent authority on request. This is one method of ensuring that the radiation protection programme and any other controls have functioned adequately.

575.6. 'Persons qualified in the carriage of radioactive material' should be taken to mean persons who possess appropriate special knowledge of the handling of radioactive material.

575.7. Consignors and carriers of irradiated nuclear fuel, plutonium or high level radioactive wastes wishing to transport these materials by sea are advised of the Code for the Safe Carriage of Irradiated Nuclear Fuel, Plutonium and High-Level Radioactive Wastes in Flasks on Board Ships (INF Code) to be found in the supplement to the IMDG Code [10]. This code assigns ships carrying these materials to one of three classes depending on the total activity of radioactive material which may be carried, and lays down requirements for each class concerning damage stability, fire protection, temperature control of cargo spaces, structural considerations, cargo securing arrangements, electrical supplies, radiological protection equipment and management, training and shipboard emergency plans.

Additional requirements relating to transport by air

576.1. This requirement relates to the presence of passengers on an aircraft rather than its capability to carry passengers. Referring to para. 203, an aircraft equipped to carry passengers, but which is carrying no passengers on that flight, may meet the

definition of a cargo aircraft and may be used for the transport of Type B(M) packages and of consignments under exclusive use.

577.1. The special conditions of air transport would result in an increased level of hazard in the case of the types of packages described in para. 577. There may be a considerable reduction in ambient air pressure at the cruising altitudes of aircraft. This is partially compensated for by a pressurization system, but that system is never considered to be 100% reliable.

577.2. If venting were permitted, this hazard would increase considerably as the outside pressure is reduced and it would be difficult to design for this to occur safely. Ancillary cooling and other operational controls would be difficult to ensure within an aircraft under normal and accident conditions.

577.3. Any liquid pyrophoric material poses a special hazard to an aircraft in flight, and severe limitations apply to such materials. Where a radioactive substance which has the subsidiary hazard of pyrophoricity is also a liquid, there is a greater probability of a spill occurring, and it is therefore absolutely forbidden to transport such a substance by air.

578.1. Because of the higher radiation levels than would normally be allowed, greater care is necessary in loading and handling. The requirement for such consignments to be transported by special arrangement ensures the involvement of the competent authority and allows special handling precautions to be specified, either during loading, in flight or at any intermediate transfer points.

578.2. The special arrangement authorization should include consideration of handling, loading and in-flight arrangements in order to control the radiation doses to flight crew, ground support personnel and incidentally exposed persons. This may necessitate special instructions for crew members, notification to appropriate persons such as terminal staff at the destination and intermediate points, and special consideration of transfer to other transport modes.

Additional requirements relating to transport by post

579.1. When shipping by post, special attention should be paid to national postal regulations to ensure that shipments are acceptable to national postal authorities.

579.2. For movement by post, the allowed levels of activity are only one tenth of the levels allowed for excepted packages by other modes of transport, for the following reasons:

- (a) The possibility exists of contaminating a large number of letters, etc., which would subsequently be widely distributed, thus increasing the number of persons exposed to the contamination.
- (b) This further reduction would result in a concurrent reduction in the maximum radiation level of a source which has lost its shielding, and this is considered to be suitably conservative in the postal environment in comparison with other modes of transport.
- (c) A single mailbag might contain a large number of such packages.

580.1. When authorization is given to an organization for the use of postal services, one suitably knowledgeable and responsible individual should be appointed to ensure that the correct procedures and limitations are observed.

CUSTOMS OPERATIONS

581.1. The fact that a consignment contains radioactive material does not, per se, constitute a reason to exclude such consignments from normal customs operations. However, because of the radiological hazards involved in examining the contents of a package containing radioactive material, the examination of the contents of packages should be carried out under suitable radiation protection conditions. A person with adequate knowledge of handling radioactive material and capable of making sound radiation protection judgements should be present to ensure that the examination is carried out without any undue radiation exposure of customs staff or any third party.

581.2. Transport safety depends, to a large extent, on safety features built into the package. Thus no customs operation should diminish the safety inherent in the package, when the package is to be subsequently forwarded to its destination. Again, a qualified person should be present to help ensure the adequacy of the package for its continued transport. A 'qualified person' in this context means a person versed in the regulatory requirements for transport as well as in the preparation of the package containing the radioactive material for onward transport.

581.3. For the examination of packages containing radioactive material by customs officials,

- (a) Clearance formalities should be carried out as quickly as possible, to eliminate delays in customs clearance which may decrease the usefulness of valuable radioactive material; and

- (b) Any necessary internal inspection should be carried out at places where adequate facilities are available and radiation protection precautions can be implemented by qualified persons.

581.4. When it is noted that a package has been damaged, the customs official should immediately provide the necessary information to a qualified person and follow the instructions of that qualified person. No person should be allowed either to remain near the package (a segregation distance of 3 m would generally be sufficient) or to touch it unless absolutely necessary. If handling is necessary, some form of protection should be used to avoid direct contact with the package. After handling it is advisable to wash hands.

581.5. When necessary, packages should be placed for temporary storage in an isolated secure place. During such storage, the segregation distance between the packages and all persons should be as great as practicable. Warning signs should be posted around the package and storage area (see also para. 568.1).

UNDELIVERABLE CONSIGNMENTS

582.1. For segregation, see para. 568.1.

REFERENCES TO SECTION V

- [1] UNITED KINGDOM ATOMIC ENERGY AUTHORITY, Shielding Integrity Testing of Radioactive Material Transport Packaging, Gamma Shielding, Rep. AECF 1056, Part 1, UKAEA, Harwell (1977).
- [2] UNITED KINGDOM ATOMIC ENERGY AUTHORITY, Testing the Integrity of Packaging Radiation Shielding by Scanning with Radiation Source and Detector, Rep. AESS 6067, UKAEA, Risley (1977).
- [3] BRITISH STANDARDS INSTITUTE, Guide to the Design, Testing and Use of Packaging for the Safe Transport of Radioactive Materials, BS 3895:1976, GR 9, BSI, London (1976).
- [4] AMERICAN NATIONAL STANDARDS INSTITUTE, American National Standard for Leakage Tests on Packages for Shipment of Radioactive Material, ANSI N.14.5-1977, ANSI, New York (1977).
- [5] INTERNATIONAL ORGANIZATION FOR STANDARDIZATION, Safe Transport of Radioactive Material – Leakage Testing of Packages, ISO 12807:1996(E), first edition 1996-09-15, ISO, Geneva (1996).
- [6] ZACHAR, M., PRETESACQUE, P., Burnup credit in spent fuel transport to COGEMA La Hague reprocessing plant, *Int. J. Radioact. Mater. Transp.* **5** 2–4 (1994) 273–278.

- [7] EWING, R.I., “Burnup verification measurements at US nuclear utilities using the Fork system”, Nuclear Criticality Safety (ICNC’95, Proc. 5th Int. Conf. Albuquerque), Vol. 2, Univ. of New Mexico, Albuquerque, NM (1995) 11.64–70.
- [8] EWING, R.I., “Application of a burnup verification meter to actinide-only burnup credit for spent PWR fuel”, Packaging and Transportation of Radioactive Materials, PATRAM 95 (Proc. 11th Int. Conf. Las Vegas, 1995), USDOE, Washington, DC (1995).
- [9] MIHALCZO, J.T., et. al., “Feasibility of subcriticality and NDA measurements for spent fuel by frequency analysis techniques with ^{252}Cf ”, Nuclear Plant Instrumentation, Control and Human–Machine Interface Technologies (Proc. Int. Top. Mtg College Station, PA), Vol. 2, American Nuclear Society, LaGrange Park, IL (1996) 883–891.
- [10] INTERNATIONAL MARITIME ORGANIZATION, International Maritime Dangerous Goods (IMDG) Code, 2000 edition including amendment 30-00, IMO, London (2001).
- [11] UNITED NATIONS ECONOMIC COMMISSION FOR EUROPE, INLAND TRANSPORT COMMITTEE, European Agreement Concerning the International Carriage of Dangerous Goods by Road (ADR), 1997 edition, marginals 10315, 71315 and Appendix B4, UNECE, Geneva (1997).
- [12] INTERNATIONAL CIVIL AVIATION ORGANIZATION, Technical Instructions for the Safe Transport of Dangerous Goods by Air, 1998–1999 edition, ICAO, Montreal (1996).
- [13] UNITED NATIONS ECONOMIC COMMISSION FOR EUROPE, INLAND TRANSPORT COMMITTEE, Regulations concerning the International Carriage of Dangerous Goods by Rail (RID), UNECE, Geneva (1995).
- [14] INTERNATIONAL AIR TRANSPORT ASSOCIATION, Dangerous Goods Regulations, 37th edition, IATA, Montreal (1996).
- [15] UNIVERSAL POSTAL UNION, Universal Postal Convention of Rio de Janeiro, UPU, Berne (1979).
- [16] UNITED NATIONS, Recommendations on the Transport of Dangerous Goods, Ninth Revised Edition, ST/SG/AC.10/1/Rev.9, UN, New York and Geneva (1995).
- [17] FAIRBAIRN, A., “The derivation of maximum permissible levels of radioactive surface contamination of transport containers and vehicles”, Regulations for the Safe Transport of Radioactive Materials — Notes on Certain Aspects of the Regulations, Safety Series No. 7, IAEA, Vienna (1961).
- [18] WRIXON, A.D., LINSLEY, G.S., BINNS, K.C., WHITE, D.F., Derived Limits for Surface Contamination, NRPB-DL2, HMSO, London (1979).
- [19] INTERNATIONAL ATOMIC ENERGY AGENCY, Monitoring of Radioactive Contamination on Surfaces, Technical Reports Series No. 120, IAEA, Vienna (1970).
- [20] INTERNATIONAL COMMISSION ON RADIOLOGICAL PROTECTION, 1990 Recommendations of the ICRP, ICRP Publication 60, Pergamon Press, Oxford (1991).
- [21] FAW, R.E., Absorbed doses to skin from radionuclide sources on the body surface, Health Phys. **63** (1992) 443–448.
- [22] TRAUB, R.J., REECE, W.D., SCHERPELZ, R.I., SIGALLA, L.A., Dose Calculations for Contamination of the Skin Using the Computer Code VARSKIN, Rep. PNL-5610, Battelle Pacific Northwest Laboratories, Richland, WA (1987).
- [23] KOCHER, D.C., ECKERMAN, K.F., Electron dose-rate conversion factors for external exposure of the skin from uniformly deposited activity on the body surface, Health Phys. **53** (1987) 135–141.

- [24] FOOD AND AGRICULTURE ORGANIZATION OF THE UNITED NATIONS, INTERNATIONAL ATOMIC ENERGY AGENCY, INTERNATIONAL LABOUR ORGANISATION, OECD NUCLEAR ENERGY AGENCY, PAN AMERICAN HEALTH ORGANIZATION, WORLD HEALTH ORGANIZATION, International Basic Safety Standards for Protection against Ionizing Radiation and for the Safety of Radiation Sources, Safety Series No. 115, IAEA, Vienna (1996).
- [25] INTERNATIONAL ORGANIZATION FOR STANDARDIZATION, Packaging of Uranium Hexafluoride (UF₆) for Transport, ISO 7195:1993(E), ISO, Geneva (1993).
- [26] UNITED STATES ENRICHMENT CORPORATION, Reference USEC-651, USEC, Washington, DC (1998).
- [27] LAUTERBACH, U., "Radiation level for low specific activity materials in compact stacks", Packaging and Transportation of Radioactive Materials, PATRAM 80 (Proc. Symp. Berlin, 1980), Bundesanstalt für Materialprüfung, Berlin (1980).
- [28] FAIRBAIRN, A., The development of the IAEA Regulations for the Safe Transport of Radioactive Materials, At. Energ. Rev. **11** 4 (1973) 843.
- [29] GELDER, R., Radiation Exposure from the Normal Transport of Radioactive Materials within the United Kingdom, NRPB-M255, National Radiological Protection Board, Chilton, UK (1991).
- [30] HAMARD, J., et. al., "Estimation of the individual and collective doses received by workers and the public during the transport of radioactive materials in France between 1981 and 1990", in Proc. Symp. Yokohama City, 1992, Science & Technology Agency, Tokyo (1992).
- [31] KEMPE, T.F., GRODIN, L., "Radiological impact on the public of transportation for the Canadian Nuclear Fuel Waste Management Program", Packaging and Transportation of Radioactive Materials, PATRAM 89 (Proc. Symp. Washington, DC, 1989), Oak Ridge National Laboratory, Oak Ridge, TN (1989).
- [32] GELDER, R., Radiological Impact of the Normal Transport of Radioactive Materials by Air, NRPB M219, National Radiological Protection Board, Chilton, UK (1990).
- [33] INTERNATIONAL ATOMIC ENERGY AGENCY, An Assessment of the Radiological Impact of the Transport of Radioactive Materials, IAEA-TECDOC-398, IAEA, Vienna (1986).
- [34] MENNERDAHL, D., "Mixing of package designs: Nuclear criticality safety", Packaging and Transportation of Radioactive Materials, PATRAM 86 (Proc. Symp. Davos, 1986), IAEA, Vienna (1986).
- [35] BOUDIN, X., et. al., "Rule relating to the mixing of planar arrays of fissile units", Physics and Methods in Criticality Safety (Proc. Top. Mtg Nashville, TN), American Nuclear Society, LaGrange Park, IL (1993) 102–111.

Section VI

REQUIREMENTS FOR RADIOACTIVE MATERIALS AND FOR PACKAGINGS AND PACKAGES

REQUIREMENTS FOR RADIOACTIVE MATERIALS

Requirements for LSA-III material

601.1. See para. 226.9.

601.2. The leaching rate limit of $0.1 A_2$ per week was arrived at by considering the case of a block of material in its packaging (e.g., a steel drum), which had been exposed to the weather and had taken in sufficient rain for the block to be surrounded with a film of water for one week. If this package is then involved in a handling accident, some of the liquid may escape and, on the basis of the standard model for determining A_2 values, 10^{-4} to 10^{-3} of this is assumed to be taken into the body of a bystander (see Appendix I). Since the package must withstand the free drop and stacking tests as prescribed in paras 722 and 723, some credit can be given for its ability to retain some of its contents: it may not be as good as a Type A package but it may well be good enough to limit escape to 10^{-2} to 10^{-3} of the dispersible contents. Since the total body intake must be limited to $10^{-6} A_2$ to maintain consistency with the safety built into Type A packages, the dispersible radioactive contents of the drum (i.e. the liquid) must therefore not exceed $0.1 A_2$.

Requirements for special form radioactive material

602.1. Special form radioactive material must be of a reasonable size to enable it to be easily salvaged or found after an incident or loss; hence the restriction on minimum size. The figure of 5 mm is arbitrary but practical and reasonable, bearing in mind the type of material normally classified as special form radioactive material.

603.1. The Regulations seek to ensure that a package containing special form radioactive material would not release or disperse its radioactive contents during a severe accident, by leakage from the sealed capsule or by dispersion/leaching of the radioactive material itself, even though the packaging may be destroyed (see Appendix I). This minimizes the predicted hazards from inhalation or ingestion of, or from contamination by, the radioactive material. For this reason special form radioactive material must be able to survive severe mechanical and thermal tests analogous

to the tests applied to Type B(U) packages without undue loss or dispersal of radioactive material at any time during its working life.

603.2. The applicant should demonstrate that the solubility of the material evaluated in the leaching test is equal to or greater than that of the actual radioactive material to be transported. Results should also be extrapolated if material with reduced radioactive contents is used in the test, in which case the validity of the extrapolation should be demonstrated. The applicant should not assume that, simply because a material is inert, it will pass the leach test without being encapsulated. For example, bare encapsulated Ir-192 pellets have failed the leach test [1]. Leaching values should be scaled up to values reflecting the total activity and form which will be transported. For material enclosed in a sealed capsule, suitable volumetric leakage assessment techniques, such as vacuum bubble or helium leakage test methods, may be used. In this case all test parameters which have an effect on sensitivity need to be thoroughly specified and accounted for in evaluating the implied loss of radioactive material from the special form radioactive material.

603.3. The Regulations allow alternative leakage assessment tests for sealed capsules. When, by agreement with the competent authority concerned, the performance tests of a capsule design are not performed with radioactive contents, the leakage assessment may be made by a volumetric leakage method. A rate of 10^{-5} Pa·m³/s for non-leachable solid contents and a rate of 10^{-7} Pa·m³/s for leachable solids, liquids and gases would in most cases be considered to be equivalent to the release of 2 kBq prescribed in para. 603 [2]. Four volumetric leak test methods are recommended as being suitable for detecting leaks in sealed capsules; these are listed in Table III together with their sensitivity.

TABLE III. COMPARISON OF THE FOUR VOLUMETRIC LEAK TEST METHODS RECOMMENDED BY ASTON et al. [3]

Leak test method	Sensitivity (Pa·m ³ /s)	Minimum void in capsule (mm ³)
Vacuum bubble		
(i) glycol or isopropyl alcohol	10^{-6}	10
(ii) water	10^{-5}	40
Pressurized bubble with isopropyl alcohol	10^{-8}	10
Liquid nitrogen bubble	10^{-8}	2
Helium pressurization	10^{-8}	10

- Leachable: Greater than 0.01% of the total activity in 100 mL in still H₂O at 50°C for 4 h, conforming to 5.1.1. ISO 9978 [2].
- Non-leachable: Less than 0.01% of the total activity in 100 mL in still H₂O at 50°C for 4 h, conforming to 5.1.1. ISO 9978.

603.4. When using non-radioactive material as a surrogate, the measurement of leaked material must be related to the limit of activity specified in para. 603(c) of the Regulations.

604.1. Where a sealed capsule constitutes part of the special form radioactive material, it should be ensured that the capsule offers no possibility of being opened by normal handling or unloading measures. Otherwise the possibility could arise that the radioactive material is handled or transported without the protecting capsule.

604.2. Sealed sources which can be opened only by destructive techniques are generally assumed to be those of welded construction. They can be opened only by such methods as machining, sawing, drilling or flame cutting. Capsules with threaded end caps or plugs, for example, which may be opened without destroying the capsule, would not be acceptable.

Requirements for low dispersible radioactive material

605.1. Limiting the external radiation level at 3 m from the unshielded low dispersible radioactive material to 10 mSv/h ensures that the potential external dose is consistent with the potential consequences of severe accidents involving Industrial packages (see para. 521).

605.2. Particles up to about 10 μm aerodynamic equivalent diameter (AED) in size are respirable and can reach deeper regions of the lung, where clearance times may be long. Particles between 10 μm and 100 μm AED are of little concern for the inhalation pathway, but they can contribute to other exposure pathways after deposition. Particles greater than 100 μm AED deposit very quickly. While this could lead to a localized contamination in the immediate vicinity of the accident, it would not represent a significant mechanism for internal exposure.

605.3. For low dispersible material the airborne release of radioactive material in gaseous or particulate form is limited to 100 A₂ when subjecting the contents of a Type B(U) package to the mechanical and thermal tests. This 100 A₂ limit refers to all particle sizes up to 100 μm AED. Airborne releases can lead to radiation exposure of persons in the downwind direction from the location of an aircraft accident via several exposure pathways. Of primary concern is a short term intake of radioactive

material through inhalation. Other pathways are much less important because their contribution is only relevant for long residence times, and remedial actions can be taken to limit exposure. For the inhalation pathway, particles below about 10 μm AED predominate because they are respirable. Nevertheless, a cautiously chosen upper limit of 100 μm was introduced in connection with the 100 A_2 limit. The rationale is that in this way it is assured that neither the inhalation pathway nor other exposure pathways following deposition could lead to unacceptable radiation doses.

605.4. When low dispersible material is subjected to the high velocity impact test, particulate matter can be generated, but of all airborne particulates up to 100 μm only a small (less than 10%) fraction will be expected to be in the respirable size range below 10 μm if the 100 A_2 limit is met. In other words, an equivalent quantity of low dispersible material less than 10 A_2 could be released airborne in a respirable size range. It has been shown that for a reference distance of around 100 m and for a large fraction of atmospheric dispersion conditions this would lead to an effective dose below 50 mSv.

605.5. In the case of the thermal test 100 A_2 of low dispersible material could be released airborne in gaseous form or as particulate with predominantly small (<10 μm AED) particle sizes because thermal processes such as combustion generally result in small particulates. Attention should be paid to the potential chemical changes of the materials during the enhanced fire test that could lead to aerosol generation, e.g. chemical reactions induced by combustion products. In the case of a fire following an aircraft accident, buoyant effects of the hot gases would lead to ground level air concentrations and to potential effective inhalation doses, which would also remain below 50 mSv for a large fraction of atmospheric dispersion conditions.

605.6. The limit on leaching of radioactive material is applied to low dispersible radioactive material to eliminate the possibility of dissolution and migration of radioactive material causing significant contamination of land and water courses, even if the low dispersible radioactive material should be completely released from the packaging in a severe accident. The 100 A_2 limit for leaching is the same as that for the release of airborne material consequent to a fire or high velocity impact.

605.7. For the specimen undergoing the impact test, consideration should be given regarding the physical interactions among source structures and individual material components comprising the low dispersible material. These interactions may result in a substantial change of the form of the low dispersible material. For example, a single fuel pellet may not produce the same quantity of dispersible material after a high velocity impact as the same pellet incorporated with other pellets into a fuel rod.

It is important that the tested specimen be representative of the low dispersible material that will be transported.

605.8. For the leaching test the specimen should incorporate a representative sample of the low dispersible material which has been subjected to the enhanced fire test and the high velocity impact test. A separate specimen may be used for each test, in which case two samples would be subjected to the leach test. For example, in the case of the impact test, the material can be broken up or otherwise separated into various solid forms including deposited powder-like material. These forms constitute the low dispersible material that should be subjected to the leaching test.

605.9. It is especially important that the measurements of airborne releases and leached material be reproducible.

GENERAL REQUIREMENTS FOR ALL PACKAGINGS AND PACKAGES

606.1. The design of a package with respect to the manner in which it is secured (retained) within or on the conveyance considers only routine conditions of transport (see para. 612).

606.2. For additional guidance on the methods of retaining a package within or on a conveyance, see paras 564.1–564.2 and Appendix V.

607.1. In the selection of materials for lifting attachments, consideration should be given to materials which will not yield under the range of loads expected in normal handling. If overloading occurs, the safety of the package should not be affected. In addition, the effects of wear should be considered.

607.2. For the design of attachment points of packages lifted many times during their lifetime, the fatigue behaviour should be taken into account in order to avoid failure cracks. Where fatigue failure may be assumed, the design should take into account the detectability of those cracks by non-destructive means, and appropriate tests should be included in the maintenance programme of the package.

607.3. Acceleration load factors (commonly called ‘snatch factors’ by rigging and handling personnel) for lifting by cranes should be related to the anticipated lifting characteristics of the cranes expected to be involved in these activities. These factors should be clearly identified. Designers should also apply acceptable design safety factors [4–6] in addition to the acceleration load factors to structural yield parameters, ensuring that there is no plastic deformation during crane lifts in any part of the package.

607.4. Special attention should be given to lifting attachments of packages handled in nuclear facilities. In addition to damage to the package itself, the dropping of heavy, robust packages onto sensitive areas could result in releases of radioactive material from other sources within the facility, or in a criticality or other event which could affect the safety of the facility. For these attachment points even higher safety margins may be required than for normal engineering practice [4–6].

608.1. This requirement is intended to prevent inadvertent use of package features that are not suitably designed for handling operations.

609.1. This requirement is imposed since protruding features on the exterior of a packaging are vulnerable to impacts during handling and other operations incidental to transport. Such impacts may cause high stresses in the structure of the packaging, resulting in tearing or breaking of containment.

609.2. In determining what is practicable as regards the design and finish of packaging, the primary consideration should be not to detract from the effectiveness of any features which are necessary for compliance with other requirements of the Regulations. For example, features provided for safe handling, operation and stowage should be designed so that, while they fulfil their essential functions under the appropriate provisions of the Regulations, any protrusions and potential difficulties of decontamination are minimized.

609.3. Cost is also a legitimate determinant of what is practicable. Measures to comply with para. 609 need not involve undue or unreasonable expense. For example, the choice of materials and methods of construction for any given packaging should be guided by commonly accepted good engineering practice for that type of packaging, always having due regard to para. 609, and need not invoke extravagantly expensive measures.

609.4. An exterior surface with a smooth finish having low porosity aids decontamination and is inherently less susceptible to absorption of contaminants and subsequent leaching out ('hide-out') than a rougher one.

610.1. This requirement is imposed because collection and retention of water (from rain or other sources) on the exterior of a package may undermine the integrity of the package as a result of rusting or prolonged soaking. Further, such retained liquid may leach out any surface contaminant present and spread it to the environment. Finally, water dripping from the package surfaces, such as rain water, may be misinterpreted as leakage from the package.

610.2. For the purposes of compliance with para. 610, considerations analogous to those in paras 609.2–609.4 should be applied.

611.1. This requirement is intended to prevent actions such as placing handling tools, auxiliary equipment or spare parts on or near the package in any manner such that the intended functions of packaging components could be impaired either during normal transport or in the event of an accident.

612.1. Components of a packaging, including those associated with the containment system, lifting attachments and retention systems, may be subject to ‘working loose’ as a result of acceleration, vibration or vibration resonance. Attention should be paid in the package design to ensure that any nuts, bolts and other retention devices remain secure during routine conditions of transport.

613.1. Consideration of the chemical compatibility of radioactive contents with packaging materials and between different materials of the components of the packagings should take into account such effects as corrosion, embrittlement, accelerated ageing and dissolution of elastomers and elastics, contamination with dissolved material, initiation of polymerization, pyrolysis producing gases and alterations of a chemical nature.

613.2. Compatibility considerations should include those materials which may be left from manufacturing, cleaning or maintaining the packaging, such as cleaning agents, grease, oil, etc., and also should include residuals of former contents of the package.

613.3. Consideration of physical compatibility should take into account thermal expansion of materials and radioactive contents over the temperature range of concern so as to cover the changes in dimensions, hardness, physical states of materials and radioactive contents.

613.4. One aspect of physical compatibility is observed in the case of liquid contents, where sufficient ullage must be provided in order to avoid hydraulic failure as a consequence of the different expansion rates of the contents and its containment systems within the admissible temperature range. Void volume values to provide sufficient ullage may be derived from regulations for the transport of other dangerous goods with comparable properties.

614.1. Locks are probably one of the best methods of preventing unauthorized operation of valves; they can be used directly to lock the valve closed or can be used

on a lid or cover which prevents access to the valve. Whilst seals can be used to indicate that the valve has not been used, they cannot be relied upon to prevent unauthorized operation.

615.1. The materials of the package should be able to withstand changes of ambient pressure and temperature likely to occur in routine conditions of transport, without impairing the essential safety features of the package.

615.2. An ambient pressure range of 60–101 kPa and an ambient temperature range of –40 to 38°C are generally acceptable for surface modes of transport. For surface movements of excepted package(s), Industrial packages Types IP-1, IP-2 and IP-3, and Type B(M) packages solely within a specified country or solely between specified countries, ambient temperature and pressure conditions other than these may be assumed providing they can be justified and that adequate controls are in place to limit the use of the package(s) to the countries concerned.

ADDITIONAL REQUIREMENTS FOR PACKAGES TRANSPORTED BY AIR

617.1. Surface temperature restrictions are necessary to protect adjacent cargo from potential damage and to protect persons handling packages during loading and unloading. This requirement is particularly restrictive for transport by air as a result of the difficulty of providing adequate free space around packages. For this reason para. 617 always applies to the air mode, whereas for other modes less restrictive surface temperature limits may be applied, under the conditions of exclusive use (see para. 662 and paras 662.1–662.4 of the Regulations). If, during transport, the ambient temperature exceeds 38°C under extreme conditions (see para. 618), the limit on accessible surface temperature no longer applies.

617.2. Account may be taken of barriers or screens intended to give protection to persons without the need for the barriers or screens being subject to any test.

618.1. The ambient temperature range of –40 to 55°C covers the extremes expected to be encountered during air transport and is the range required by the International Civil Aviation Organization [7] for packaging any dangerous goods, other than ‘ICAO excepted goods’, destined for air transport.

618.2. In designing the containment, the effect of ambient temperature extremes on resultant surface temperatures, contents, thermal stresses and pressure variations should be considered to ensure containment of the radioactive material.

619.1. This is a similar provision to that required by the International Civil Aviation Organization [7] for packages containing certain liquid hazardous material intended for transport by air. In this edition of the Regulations the provision has been expanded to include all forms of radioactive material.

619.2. Pressure reductions due to altitude will be encountered during flight (see para. 577.1). The pressure differential which occurs at an increased altitude should be taken into account in the packaging design. The 5 kPa is the minimum ambient pressure to be accommodated by the designer (this results from a consideration of aircraft depressurization at a maximum civil aviation flight altitude, together with a safety margin).

REQUIREMENTS FOR EXCEPTED PACKAGES

620.1. See para. 515.1.

REQUIREMENTS FOR INDUSTRIAL PACKAGES

Requirements for Industrial package Type 1 (Type IP-1)

621.1. According to the radiological grading of LSA material and SCOs, the three Industrial package types have different safety functions. Whereas Type IP-1 packages simply contain their radioactive contents under routine transport conditions, Type IP-2 and IP-3 packages protect against loss or dispersal of their contents and loss of shielding under normal conditions of transport, which by definition (see para. 106) include minor mishaps, as far as the test requirements represent these conditions. Type IP-3 packages, in addition, provide the same package integrity as a Type A package intended to carry solids.

621.2. Neither the Industrial package design requirements of the Regulations nor United Nations packing group III design requirements regard packages as pressure vessels. In this respect, only those pressure vessels which have a volume of less than 450 L in the case of liquid contents and of less than 1000 L in the case of gaseous contents can be considered packages. Pressure vessels with greater volumes are defined as tanks, for which paras 625 and 626 provide a comparable level of safety. In the event that pressure vessels are used as Industrial packages, the design principles of relevant pressure vessel codes should be taken into account for the selection of materials, design/calculation rules and quality assurance requirements for the manufacturing and use of the package (e.g. pressure testing by independent inspectors). The comparably

high wall thickness of pressure vessels is usually foreseen to provide safety with respect to internal service and/or test pressure. A design pressure higher than that needed to cover service conditions corresponding to the vapour pressure at the upper temperature limit may provide a margin of safety against mishaps or even accidents by necessitating a greater thickness of wall. In this case, it may not be necessary to prove safety by drop and stacking performance tests, but rather the pressure test could suffice. However, the safety of associated service equipment (valves, etc.) against mechanical loads needs to be ensured, for example by the use of additional protective structures.

621.3. Pressure vessels with volumes less than 450 L for liquid contents and 1000 L for gaseous contents, and designed for a pressure of 265 kPa (see para. 625(b)), may provide an adequate level of safety and consequently may not need to be subjected to the Type IP tests. It is understood that all precautions specified by the relevant pressure vessel codes for the use of pressure vessels are taken into consideration and applied as appropriate.

621.4. An example for this application is the pressure vessels used for the transport of uranium hexafluoride (UF_6). These cylinders are designed for a pressure much higher than occurs under normal transport and service conditions. They are therefore inherently protected against mechanical loads.

621.5. The ullage requirement (see para. 647) is not specified as a requirement for the Industrial packages. However, in the case of liquid contents, or solid contents such as UF_6 which may become liquid in the event of heating, sufficient ullage should be provided, as referred to in para. 647, in order to prevent rupture of the containment. Such rupture may occur in the case of insufficient ullage, especially as a result of expansion of contents with temperature changes.

Requirements for Industrial package Type 2 (Type IP-2)

622.1. Consideration of the release of contents from Type IP-2 packages imposes a containment function on the package for normal conditions of transport. Some simplification in demonstrating no loss or dispersal of contents is possible owing to the rather immobile character of some LSA material and SCO contents and the limited specific activity and surface contamination. See also paras 646.2–646.5.

622.2. See paras 621.1 and 226.1.

622.3. For a Type IP-2 packaging intended to carry a liquid, see paras 621.2–621.5. For a Type IP-2 packaging intended to carry a gas, see paras 621.2–621.4. For a Type IP-2 packaging intended to carry LSA-III material, see para. 226.9.

622.4. For packages exhibiting little external deformation and negligible internal movement of the radioactive contents or shielding, a careful visual examination may provide sufficient assurance that the surface radiation level is essentially unchanged.

622.5. If it is considered that a surface radiation level has probably increased, monitoring tests should be performed to ensure that the increase in the radiation level does not exceed 20%.

622.6. The method of evaluating the loss of shielding varies from one manufacturer to another. This could lead to discrepancies in evaluating a package's ability to satisfy the requirements of para. 622(b). One way of overcoming this problem may be to define the maximum surface area of the package over which the surface radiation level is assessed. Thus, for example, individual measurements may be taken over areas not greater than 10% of the total surface area of the package. The package surface may be marked to define the subdivisions to be considered and tests conducted by means of a test source suitable for the package (i.e. Co-60 or Na-24 for general package use or specific nuclides for a certain package design). It may be necessary to consider the effect of increased localized radiation levels when evaluating shielding loss.

622.7. The loss of shielding should be evaluated on the basis of the measurements taken both before and after the tests specified in para. 622, and the resulting data should be compared to determine whether the package satisfies the requirement or not.

Requirements for Industrial package Type 3 (Type IP-3)

623.1. Consideration of the release of contents from Type IP-3 packages imposes the same containment function on Type IP-3 packages as for Type A packages for solids, with account taken of the higher values of specific activity which may be transported in Type IP-3 packages and the absence of operational controls in non-exclusive use transport. In addition, sufficient ullage should be foreseen in the case of liquid LSA material in order to avoid hydraulic failure of the containment system. These requirements are consistent with the graded approach of the Regulations. See also paras 646.2–646.5.

623.2. See paras 621.1 and 226.1.

623.3. For a Type IP-3 package intended to carry a liquid, see paras 621.2–621.5. For a Type IP-3 package intended to carry a gas, see paras 621.2–621.4. For a Type IP-3 package intended to carry LSA-III material, see para. 226.9.

Alternative requirements for Industrial package Types 2 (Type IP-2) and 3 (Type IP-3)

624.1. The alternative use of United Nations packagings is allowed because the United Nations Recommendations [8] require comparable general design requirements and performance tests which have been judged to provide the same level of safety. Whereas leaktightness is also one of the performance test criteria in the United Nations Recommendations, this is not the case with respect to the shielding requirements in the Regulations, which need special attention when United Nations packagings are used.

624.2. As United Nations packing groups I and II require the same or even more stringent performance test standards compared with those for Type IP-2 packages, Type IP-2 test requirements are automatically complied with by all of the United Nations packing groups I and II except as stated in para. 624.3. This means that packagings marked with X or Y according to the United Nations system are potentially suitable for the transport of LSA materials and SCOs requiring a Type IP-2 package when no specific shielding is required. For these packages, there should be consistency between the contents being shipped and the contents tested in the UN tests, including consideration of maximum relative density, gross mass, maximum total pressure, vapour pressure and the form of the contents.

624.3. United Nations packagings of packing groups I and II, i.e. packagings which meet the specifications given in Chapter 9 of the United Nations Recommendations on the Transport of Dangerous Goods [8], may be used as Type IP-2 packages provided there is no loss or dispersal of the contents during or after the UN tests. It should be noted however that a slight discharge from the closure upon impact is permitted under the UN standard if no further leakage occurs. This discharge would not meet the requirement for no loss or dispersal of the contents. In addition, the intended contents should be consistent with those allowable in the particular packaging, and specific shielding should not be required. The applicable restrictions can be determined from the United Nations marking which must appear on United Nations specification packagings.

625.1. Tank containers designed for the transport of dangerous goods according to international and national regulations have proved to be safe in handling and transport, in some cases even under severe accident conditions.

625.2. The general design criteria for tank containers with respect to safe handling, stacking and transport can be complied with if the structural equipment (frame) is designed in accordance with ISO 1496-3 [9]. This standard prescribes a structural

framework in which the tank is attached in such a manner that all static forces of handling, stowage and transport produce no undue stresses on the shell of the tank.

625.3. The dynamic forces under routine conditions of transport are considered in Appendix V.

625.4. Tank containers designed according to ISO 1496-3 are considered to be at least equivalent to those that are designed to the standards prescribed in the chapter on Recommendations on Multimodal Tank Transport of the United Nations Recommendations on the Transport of Dangerous Goods [8].

625.5. The shielding retention requirement (para. 625(c)) is complied with if after the tests the shielding material remains in place, shows no significant cracks and permits no more than a 20% increase in the radiation level as evaluated by calculation and/or measurements under the above mentioned conditions. In the case of tank containers with an ISO framework, the radiation level calculations/measurements may take the surfaces of the framework as the relevant surfaces.

626.1. To explain the equivalence between tank standards and those prescribed in para. 625 (UN recommendations, Chapter 12 for tank containers), reference should be made to the European Agreement Concerning the International Carriage of Dangerous Goods by Road (ADR) 1995 [10], where Appendix B.1A prescribes the requirements for road tank vehicles that are basically providing the same safety level as the requirements for tank containers in Appendix B.1B. A similar comparison can be found in the European Agreement on Railway Transport (RID) [11] for rail tank wagons and tank containers in Appendices X and XI of the Agreement.

627.1. Freight containers designed and tested to ISO 1496-1 [12] and approved in accordance with the CSC Convention [13] have been proved, by the use of millions of units, to provide safe handling and transport under routine conditions of transport. It should be noted however that ISO 1496-1 addresses issues relating to container design and testing whereas the CSC Convention is primarily concerned with ensuring that containers are safe for transport, are adequately maintained and are suitable for international shipment by all modes of surface transport. The testing prescribed in CSC is not equivalent to that prescribed in ISO 1496-1.

627.2. Freight containers designed and tested to ISO 1496-1 are restricted to the carriage of solids because they are not regarded as being suitable for free liquids or liquids in non-qualified packagings. Consideration should be given to the construction details of the container to ensure that the containment requirements can be met. Only closed freight containers can be used to demonstrate compliance with the

Type IP-2 and Type IP-3 containment requirement of no loss or dispersal of radioactive contents, and monitoring during and after testing is necessary to demonstrate this. Closed freight containers also include freight containers with openings on top, if these openings are safely closed during transport.

627.3. Freight containers must be shown to retain and contain their contents during accelerations occurring in routine transport because the ISO Standard Tests for freight containers do not include dynamic tests.

627.4. Care must be taken to ensure that attachments used within the container to secure objects can withstand loads typical of routine conditions of transport (see Appendix V).

627.5. For guidance on preventing the loss or dispersal of contents and the loss of shielding integrity, see paras 622.1–622.7.

628.1. Intermediate bulk containers approved according to provisions on the basis of Chapter 16 of the United Nations Recommendations on the Transport of Dangerous Goods [8] are considered to be equivalent to packages designed and tested in accordance with the Type IP-2 and Type IP-3 requirements, except with regard to any shielding requirements. The alternative use of intermediate bulk containers is restricted to metal designs only because they provide the closest match with Type IP-2 and Type IP-3 package requirements. The need for other design types could not be identified, and they do not seem to be appropriate for the transport of radioactive material.

628.2. Compliance with the Type IP-2 and Type IP-3 design and performance test requirements may, with the exception of any shielding requirement, be demonstrated for intermediate bulk containers when they conform to provisions based upon the UN Recommendations on the Transport of Dangerous Goods [8], Chapter 16, with the additional requirement for intermediate bulk containers with more than 0.45 m³ capacity to perform the drop test in the most damaging position (and not only onto the base). These recommendations include comparable design and performance test requirements as well as the design approval by the competent authority.

REQUIREMENTS FOR PACKAGES CONTAINING URANIUM HEXAFLUORIDE

629.1. Uranium hexafluoride is a radioactive material having significant chemical hazard where, however, the UN Recommendations require that the radioactive nature

of the substance take precedence and the chemical hazard be treated subsidiary to the radioactive risk [8]. Depending on the degree of enrichment and amount of fissile uranium, uranium hexafluoride may be transported, from the radiological standpoint, in excepted, Industrial packages, Type A or Type B. Thus, the radiological and fissile properties of uranium hexafluoride are covered by other aspects of the Regulations. However, many of the requirements for uranium hexafluoride imposed by way of ISO 7195 [14] and by the requirements now embodied in the Regulations do not relate to the radiological and fissile hazards posed by uranium hexafluoride, but to the physical properties and also to the chemical toxic hazard of the material when released to the atmosphere and reacted with water or water vapour. In addition, since these packagings are pressurized during loading and unloading operations, they have to comply with pressure vessel regulations, although they are not pressurized under normal transport conditions. The requirements specified in paras 629–632 of the Regulations are focused on these concerns and not on radiological and fissile hazards. Other applicable requirements of ST-1 relating to the radiological and fissile nature of the uranium hexafluoride being packaged and transported, found elsewhere in the Regulations, are vital to providing proper safety during handling and transport and should therefore be taken into account in both the packaging and transport of uranium hexafluoride.

630.1. The 0.1 kg exemption level provides assurance against the explosion of small, bare cylinders of UF_6 [15]. The 0.1 kg level is well below the toxic risk limit of 10 kg, based on Refs [16, 17].

630.2. The acceptance criteria in paras 630(a), (b) and (c) vary depending upon the type of environment to which the package is exposed. For the pressure test specific to uranium hexafluoride packages (para. 718), the requirement for acceptance without leakage and without unacceptable stress may be satisfied by hydrostatic testing of the cylinder, where leaks may be detected by observing for evidence of water leakage from the cylinder. The valve and other service equipment are not included in this pressure test (ISO 7195).

630.3. For the drop test (para. 722), acceptance may be evidenced by performing a gas leakage test consistent with the procedure, pressure and sensitivity specified for valve leak testing in ISO 7195.

630.4. The criteria for acceptance during or following exposure of a package containing uranium hexafluoride to the thermal test (para. 728) is based upon considerations of the desire to prevent tearing of the cylinder shell. Concerning the allowable release, a necessary acceptance criterion would be the demonstration of “without rupture” of the cylinder, where again consideration is not given to leakage by service equipment such as through and around valves. Consistent with the

philosophy used as guidance for “no rupture of the containment system” used in para. 657, tearing or major failure of the uranium hexafluoride cylinder walls would be unacceptable, but minor leakage through or around a valve or other engineered penetration into the cylinder wall may be acceptable subject to competent authority approval.

630.5. It may be difficult if not impossible to demonstrate compliance with the leakage, loss or dispersal, rupture and stress requirements of para. 630 through testing with uranium hexafluoride in the packagings because of major environmental, health and safety concerns. Thus, demonstration of compliance may need to depend upon surrogates for the uranium hexafluoride in tests combined with reference to previous satisfactory demonstrations, laboratory tests, calculations and reasoned arguments as elaborated upon in para. 701.

630.6. For the demonstration of compliance of packages containing uranium hexafluoride with the requirements of para. 630(c), the designer should take into account the influence of the parameters that may alter the transient thermophysical conditions of uranium hexafluoride and the packaging which may be encountered in the thermal test. The designer should consider, at a minimum, the following:

- (a) The most severe orientation of the package: Changing the orientation of the package might produce a different distribution of the three physical phases of uranium hexafluoride (solid, liquid and gas) inside the package, and could lead to different consequences on internal pressure [18, 19].
- (b) The full range of allowed filling ratios: The pressure inside the cylinder could be dependent, in a complex fashion, upon the extent to which it is filled. For example, for very small filling ratios, the solid uranium hexafluoride could melt and evaporate faster, thereby accelerating the pressure increase inside the package [20].
- (c) The actual properties of the structural materials at high temperatures: For example, a large reduction in tensile strength of steel occurs at temperatures above 500°C [21].
- (d) The presence of metallurgical defects in the structure material could cause the rupture of the package. This would be a function of the defect size. The maximum design defect size should be derived from design analyses, the manufacturing process and inspection acceptance criteria.
- (e) Thinning of the wall of the cylinder or other packaging components resulting from corrosion could result in reduced performance. The designer should establish a minimum acceptable wall thickness, and methods for determining wall thicknesses for both unfilled and filled, in-service cylinders should be developed and applied [22, 23].

631.1. This provision is included since it is unlikely that a pressure relief device can be provided which is sufficiently reliable to assure a desired level of release and subsequent closure once the pressure reduces to acceptable levels.

632.1. Packages designed to carry 0.1 kg or more of uranium hexafluoride which are not designed to withstand the 2.76 MPa pressure test, but are designed to withstand a pressure test of at least 1.38 MPa, may be authorized for use subject to approval by the competent authority. This is to allow older package designs which can be demonstrated to the satisfaction of the competent authority to be safe to be used subject to multilateral approval. The package designer should prepare the safety case for justifying this certification.

632.2. Very large packages containing uranium hexafluoride, which are designed to contain 9000 kg or more of uranium hexafluoride and which are not transported in thermal protecting overpacks, have been considered possibly to have sufficient thermal mass to survive exposure to the thermal test of para. 728 without rupture of the containment system. Subject to approval of the competent authority, these packages may be certified for shipment on a multilateral basis, and the package designer should prepare the safety case for justifying this certification.

632.3. See also 630.5.

REQUIREMENTS FOR TYPE A PACKAGES

634.1. The minimum dimension of 10 cm has been adopted for a number of reasons. A very small package could be mislaid or slipped into a pocket. In order to conform to international transport practice, package labels have to be 10 cm square. To adequately display these labels, the dimensions of the packages are required to be at least 10 cm.

635.1. Requiring a package seal is intended both to discourage tampering and to ensure that the recipient of the package knows whether or not the contents and/or the internal packaging have been tampered with or removed during transport. While the seal remains intact the recipient is assured that the contents are those stated on the label; if the seal is damaged, the recipient will be warned that extra caution will be required during handling and particularly on opening the package.

635.2. The type and mass of the package will, in the main, dictate the type of security seal to be used, but designers should ensure that the method chosen is such that it will not be impaired during normal handling of the package in transport.

635.3. There are many methods of sealing but the following are typical of those used on packages for radioactive material:

- (a) When the packaging is a fibreboard carton, gummed or self-adhesive tape which cannot be reused to seal the package may be used (the outer packaging and/or the tape will be effectively destroyed on being opened).
- (b) Crimped metal seals may be used on the closures of drums, lead and steel pots and small boxes. The seals are crimped onto the ends of a suitable lace or locking wire and are embossed with an identifying pattern. The method used to secure the closure itself should be independent of the security seal.
- (c) Padlocks may be used on timber boxes and also for steel or lead/steel packages. A feature such as a drilled pillar is incorporated into the box or packaging design so that when the padlock is fitted through the drilled hole it is not possible to gain entry into the package.

636.1. With the exception of tanks or packages used as freight containers, the securing of packages which have a considerable mass relative to the mass of the conveyance will in general be accomplished using standard equipment suitable for restraining such large masses. Since the retention system 'shall not impair' the functions of the package under normal and accident loading conditions, it may be necessary to design the attachment of the retention system to the package so that it would fail first (commonly called the 'weak link'). This can be accomplished, for example, by designing the attachment point so that it will accommodate only a certain maximum size of shackle pin, or be held by pins that would shear, or bolts that would break, at a designated stress.

636.2. Lifting points may be used as retention system attachments, but if so used they should be designed specifically for both tasks. The separate lifting points and retention system attachments should be clearly marked to indicate their specific purposes, unless they can be so designed that alternative use is impossible, e.g. a hook type of retention system attachment cannot normally be used for retention purposes.

636.3. Consideration can also be given to potential directional failure of the retention systems so that the transport workers are protected in the event of head-on impacts, while the package is protected against excessive side loads from side-on impacts [24]. For details on recommended design considerations of packages and their retention systems, see Appendix V.

637.1. Type A package components should be designed for a temperature range from -40 to 70°C corresponding to possible ambient temperatures within a vehicle or other enclosure, or package temperatures when the package is exposed to direct

sunlight. This range covers the conditions likely to be encountered in routine transport and storage in transit. If a wider environmental temperature range is likely to be encountered during transport or handling or there is significant internal heat generation, then this should be allowed for in the design. Some of the items that may need consideration are:

- expansion/contraction of components relative to structural or sealing functions;
- decomposition or changes of state of component materials at extreme conditions;
- tensile/ductile properties and package strength; and
- shielding design.

638.1. Many national and international standards exist (e.g. Refs [2, 9, 12, 15, 25–28]) covering an extremely wide range of design influences and manufacturing techniques, such as pressure vessel codes, welding standards or leaktightness standards, which can be used in the design, manufacturing and testing of packages. Designers and manufacturers should, wherever possible, work to these established standards in order to promote and demonstrate adequate control in the overall design and manufacture of packages. The use of such standards also means that the design and manufacturing processes are more readily understood by all relevant people, sometimes in different locations and Member States, involved in the various phases of transport; most importantly, package integrity is much less likely to be compromised.

638.2. Where new or novel design, manufacturing or testing techniques are proposed for use and there is no appropriate existing standard, the designer may need to discuss the proposals with the competent authority to obtain acceptance. Consideration should be given by the designer, the competent authority or other responsible bodies to developing an acceptable standard covering any new design concept, manufacturing or testing technique, or material to be used.

639.1. Examples of positive fastening devices which may be suitable are:

- welded seams
- screw threads
- snap-fit lids
- crimping
- rolling
- peening
- heat shrunk materials, and
- adhesive tapes or glues.

Other methods may be appropriate depending on the package design.

640.1. In the case of packages where containment of the radioactive contents is achieved by means of special form radioactive material, attention is drawn to the requirements of para. 502(f) with respect to each shipment.

642.1. Certain materials may react chemically or radiolytically with some of the substances intended to be carried in Type A packages. Tests may be required to determine the suitability of materials to ensure that the containment system is neither susceptible to deterioration caused by the reactions themselves, nor damaged by the pressure increase consequent upon those reactions.

643.1. This requirement is intended to prevent an excessive pressure differential arising in a package that has been filled at sea level (or below) and is then carried by surface transport to a higher altitude. The minimum requirement for packages subject to air pressure variations resulting from altitude changes is that resulting from surface movements to altitudes as high as 4000 m. If the package could be sealed at or below sea level and transported over land to this altitude, the package must be able to withstand an overpressure resulting from this change in altitude as well as being able to withstand any overpressure that may be generated by its contents.

643.2. For guidance on the requirement for the retention of radioactive contents, see paras 646.2–646.5.

644.1. To prevent contamination caused by leakage of contents through valves, a provision for some secondary device or enclosure for these valves is required by the Regulations. Depending upon the specific design, such a device or enclosure may help to prevent the unauthorized operation of the valve, or in the event of leakage to prevent the contents from escaping.

644.2. Examples of enclosures which may be suitable are:

- blank caps on threaded valves using gaskets;
- blank flanges on flanged valves using gaskets; and
- specially designed valve covers or enclosures, using gaskets, designed to retain any leakage.

Other methods may be appropriate depending on the package design.

645.1. The requirement of para. 645 is primarily intended to ensure that the radiation shield is constantly maintained around the radioactive substance to minimize any

increase in radiation levels on the surface of the package. When the radiation shield is a separate unit, the positive fastening device ensures that the containment system is not released except by intent.

645.2. Examples of design features which may be suitable are:

- hinge operated interlock devices on covers;
- bolted, welded or padlocked frames surrounding the radiation shield; and
- threaded shielding plugs.

Other methods may be appropriate depending on the package design.

646.1. The design of, and contents limits imposed upon, Type A packages intrinsically limit any possible radiological hazard. This paragraph provides the restrictions on release and degradation of shielding during normal conditions of transport so as to ensure safety.

646.2. A maximum allowable leakage rate for the normal transport of Type A packages has never been defined quantitatively in the Regulations but it has always been required in a practical sense.

646.3. Practically, it is difficult to advise on a single test method that could satisfactorily incorporate the vast array of packagings and their contents that exist. A qualitative approach, dependent upon the packaging under consideration and its radioactive contents, may be employed. In applying the preferred test method the maximum differential pressure used should be that resulting from the contents and the expected ambient conditions.

646.4. For solid, granular and liquid contents, one way of satisfying the requirements for 'no loss or dispersal' would be to monitor the package (containing a non-active, control material) on completion of a vacuum test or other appropriate tests to determine visually whether any of the contents have escaped. For liquids, an absorbent material may be used as a test indicator. Thereafter, a careful visual inspection of the package may confirm that its integrity is maintained and no leakage has occurred. Another method which may be suitable in some cases would be to weigh the package before and after a vacuum test to determine whether any leakage has occurred.

646.5. For gaseous contents, visual monitoring is unlikely to be satisfactory and a suction detection or pressurization method with a readily identifiable gas (or volatile liquid providing a gaseous presence) may be used. Again, a careful visual inspection

of the packaging may confirm that its integrity has been maintained and no escape paths exist. Another detection method would be a simple bubble test.

646.6. For advice concerning loss of shielding integrity, see paras 622.4–622.7.

647.1. Ullage is the gas filled space available within the package to accommodate the expansion of the liquid contents of the package due to changes in environmental and transport conditions. Adequate ullage ensures that the containment system is not subjected to excessive pressure due to the expansion of liquid-only systems, which are generally regarded as incompressible.

647.2. When establishing ullage specifications it may be necessary to consider both extremes of package material temperature, -40°C and $+70^{\circ}\text{C}$ (see para. 637). At the lower temperature, pressure increases may occur as a result of expansion at transitional temperatures where the material changes its state from liquid to solid. At the higher temperature, pressure increases may occur as a result of expansion or vaporization of the liquid contents. Consideration may also be needed to ensure that no excessive ullage is provided as this may allow unacceptable dynamic surges within the package during transport. In addition, surging or lapping may occur during filling operations involving large liquid quantities, and designers may need to consider this aspect for certain package designs.

648.1. The purpose of these two additional requirements is to demonstrate either an increased capability of a Type A packaging for liquids to withstand impacts and hence to indicate that the fraction of the contents that would be released in an accident would be comparable with that released from a Type A package designed to carry dispersible solids, or to provide a supplementary safety barrier, thereby reducing the probability of the liquid escaping from the package even if it escapes from the primary inner containment components.

648.2. A user of a Type B(U) or a Type B(M) package may wish to use that package for shipping less than an A_2 quantity of liquid and to designate this package in the shipping papers as a Type A package shipment. This lifts some administrative burdens from the consignor and carrier and, since the package has a greater integrity than a standard Type A package, safety is not degraded. In this case, there is no requirement to meet the provision of adding absorbent material or a secondary outer containment component.

649.1. The reasons for additional tests for Type A packaging for compressed or uncompressed gases are similar to those for Type A packagings for liquids (see para. 648.1). However, since in the case of gases failure of the containment would always

give 100% release, the additional test is required to reduce the probability of failure of the containment for a given severity of accident and thus achieve a level of risk comparable with that of a Type A package designed to carry dispersible solids.

649.2. The exception of packages containing tritium or noble gases from the requirement in para. 649 is based upon the dosimetric models for these materials (the Q system, see discussion in Appendix I).

649.3. For guidance on the requirement of no loss or dispersal of gaseous radioactive contents, see para. 646.5.

REQUIREMENTS FOR TYPE B(U) PACKAGES

650.1. The concept of a Type B(U) package is that it is capable of withstanding most of the severe accident conditions in transport without loss of containment or increase in external radiation level to an extent which would endanger the general public or those involved in rescue or cleanup operations. It should be safely recoverable (see paras 510 and 511), but it would not necessarily be capable of being reused.

651.1. Although the requirement in para. 637, which is for Type A packages, is intended to cover most conditions which can result in packaging failure, additional consideration of packaging component temperatures is required for Type B(U) packages on a design specific basis. This is generally because Type B(U) packages may be designed for contents which produce significant amounts of heat, and component temperatures for such a design may exceed the 70°C requirement for Type A packages. The intent of specifying an ambient temperature of 38°C for package design considerations is to ensure that the designer properly addresses packaging component temperatures and the effect of these temperatures on geometry, shielding, efficiency, corrosion and surface temperature. Furthermore, the requirement that a package be capable of being left unattended for a period of one week under an ambient temperature of 38°C with solar heating is intended to ensure that the package will be at, or close to, equilibrium conditions and that under these conditions it will be capable of withstanding the normal transport conditions, demonstrated by tests according to paras 719–724, without loss of containment or reduction in radiation shielding.

651.2. The evaluation to ambient temperature conditions must account for heat generated by the contents, which may be such that the maximum temperature of some package components may be considerably in excess of the maximum of 70°C required for a Type A package design.

651.3. See also paras 637.1, 652.1, 652.2, 654.1–654.9, 664.1–664.3 and Appendix VI.

651.4. Practical tests may be used to determine the internal and external temperatures of the package under normal conditions by simulating the heat source due to radioactive decay of the contents with electrical heaters. In this way, the heat source can be controlled and measured. Such tests should be performed in a uniform and steady thermal environment (i.e. fairly constant ambient temperature, still air and minimum heat input from external sources such as sunlight). The package with its heat source should be held under test for sufficient time to allow the temperatures of interest to reach steady state. The test ambient temperature and internal heat source should be measured and used to adjust linearly all measured package temperatures to those corresponding to a 38°C ambient temperature.

651.5. For tests performed in uncontrolled environments (e.g. outside), ambient variations (e.g. diurnal) may make it impossible to achieve constant steady state temperatures. In such cases, the periodic quasi-steady-state temperatures should be measured (both ambient and package), allowing correlations to be made between ambient and package average temperatures. These results, together with data on the internal heat source, can be used to predict package temperatures corresponding to a steady 38°C ambient temperature.

652.1. The surface temperatures of packages containing heat generating radioactive materials will rise above the ambient temperature. Surface temperature restrictions are necessary to protect adjacent cargo from potential damage and to protect persons handling packages during loading and unloading.

652.2. With a surface temperature limit of 50°C at the maximum ambient temperature of 38°C, other cargo will not become overheated nor will anyone handling or touching the surface suffer a burn. A higher surface temperature is permitted under exclusive use (except for transport by air); see para. 662 of the Regulations and paras 662.1–662.4.

653.1. See para. 664.1.

654.1. During transport, a package may be subjected to solar heating. The effect of solar heating is to increase the package temperature. To avoid the difficulties in trying to account for the many variables precisely, values for insolation have been agreed upon internationally (they are presented in Table XI of the Regulations). The insolation values are specified as uniform heat fluxes applied for 12 h and followed by 12 h of zero insolation. Packages are assumed to be in the open; therefore, neither shading

nor reflection from adjacent structures is considered. Table XI shows a maximum value of insolation for an upward facing horizontal surface and zero for a downward facing horizontal surface which receives no insolation. A vertical surface is assumed to be heated only half a day and only half as effectively; therefore, the table value for insolation of a vertical surface is given as one quarter the maximum value for an upward facing flat surface. Locations on curved surfaces vary in orientation between horizontal and vertical and are judiciously assigned half the maximum value for upward facing horizontal surfaces. The use of the agreed upon values ensures uniformity in any safety assessment, providing a common ground for the purpose of calculation.

654.2. The insolation data provided in Table XI of the Regulations are uniform heat fluxes. They are to be applied at the levels stated for 12 h (daylight) followed by 12 h of no insolation (night). The cyclic step functions representing insolation should be applied until the temperatures of interest reach conditions of steady periodic behaviour.

654.3. A simple but conservative approach for evaluating the effects of insolation is to apply uniform heat flux continuously at the values stated in Table XI. Use of this approach avoids the need to perform transient thermal analysis; only a simple steady state analysis is performed.

654.4. For a more precise model, a time dependent sinusoidal heat flux may be used to represent insolation during daylight hours for flat surfaces or for curved surfaces. The integrated (total) heat input to a surface between sunrise and sunset is required to be equal to the appropriate value of total heat for the table values over 12 h (i.e. multiply the table value by 12 h to get total heat input in W/m^2). The period between sunset and sunrise gives zero heat flux for this model. The cyclic insolation model should be applied until the temperatures of interest reach conditions of steady periodic behaviour.

654.5. Downward facing flat surfaces cannot receive any insolation, and the Table XI value of 'none' applies. For any upward facing horizontal surface, the Table XI value is applicable. Non-horizontal surfaces may include vertical or nearly vertical surfaces (i.e. up to 15° off the vertical); for these surfaces, the Table XI value for vertical surfaces applies. For upward tilted flat surfaces that are more than 15° off the vertical, the horizontal projection of the area may be used in conjunction with the insolation value for a flat upward facing horizontal surface. For downward tilted flat surfaces that are more than 15° off the vertical, the vertical projection of the area may be used in conjunction with the insolation value for a flat vertical surface.

654.6. The insolation value for curved surfaces given in Table XI should be applied to all curved surfaces of any orientation.

654.7. Components of the package that reduce insolation to any surface (i.e. provide solar shade to the surface of the package) may be taken into account in the thermal evaluation. Any such components assumed to reduce insolation should not be included in the thermal evaluation if their effectiveness would be reduced as a result of the package being subjected to the tests for normal conditions of transport.

654.8. Because radiation heat transfer depends on the emissivity and absorptivity at a surface, variations in these properties may be taken into account. These surface properties are wavelength dependent. Solar radiation corresponds to high temperature and short wavelength radiation, while surface radiation from packages corresponds to relatively low temperature and longer wavelength radiation. In many cases, the absorptivity will be lower than the emissivity, so using the higher value for both will give a larger margin of safety when the objective is heat dissipation. In other cases, advantage might be taken of naturally occurring differences in these properties, or the surface could be treated to take advantage of such differences to reduce the effect of insolation. When differences in surface properties are used as a means of thermal protection to reduce insolation effects, the performance of the thermal protection system should be demonstrated, and the system should be shown to remain intact under normal conditions of transport.

654.9. Evaluation of the package temperature for transport of radioactive material may be done by analysis or test. Tests, if used, should be performed on full scale models. If the radiation source is not sunlight, differences between solar wavelength and the source wavelength should be taken into account. The test should continue until thermal equilibrium is achieved (either constant steady state or steady periodic state, depending on the source). Corrections should be made for ambient temperatures and internal heat, where necessary.

655.1. In general, coatings for thermal protection fall into two groups: those which undergo a chemical change in the presence of heat (e.g. ablative and intumescent) and those which provide a fixed insulation barrier (including ceramic materials).

655.2. Both groups are susceptible to mechanical damage. Materials of the ablative and intumescent type are soft and can be damaged by sliding against rough surfaces (such as concrete or gravel) or by the movement of hard objects against them. In contrast, ceramic materials are very hard, but are usually brittle and unable to absorb shock without cracking or fracturing.

655.3. Commonly occurring incidents which could cause damage to the thermal protection materials include: relative movement between package and contact surfaces of vehicle during transport; skidding across a road in which surface gravel is embedded; sliding over a damaged rail track or against the edge of a metal member; lifting or lowering against bolt heads of adjacent structures or equipment; impact of other packages (not necessarily containing radioactive material) during stowage or transport; and many other situations which would not result from the tests required in paras 722–727. Packages that are tested by a simple drop test do not receive damage to the surface representative of the rolling and sliding action usually associated with a vehicle accident, and packages subsequently thermally tested may have a coating which under practical accident conditions might be damaged.

655.4. The damage to a thermal protection coating may reduce the effectiveness of the coating, at least over part of the surface. The package designer should assess the effects of this kind of damage.

655.5. The effects of age and environmental conditions on the protective material also need to be taken into account. The properties of some materials change with time, and with temperature, humidity or other conditions.

655.6. A coating may be protected by adding skids or buffers which would prevent sliding or rubbing against the material. A durable outer skin of metal or an overpack may give good protection but might alter the thermal performance of the package. The external surface of the package may also be designed so that thermal protection can be applied within recesses.

655.7. With the agreement of the competent authority, thermal tests with arbitrary damage to the thermal protection of a package may be made, to show the effectiveness of damaged thermal protection, where it can be shown that such damage will yield conservative test results.

656.1. The concept of specifying containment standards for large radioactive source packages in terms of activity loss in relation to specified test conditions was first introduced in the 1967 edition of the Regulations.

656.2. The release rate limit of not more than $A_2 \times 10^{-6}$ per hour for Type B(U) packages following tests to demonstrate their ability to withstand the normal conditions of transport was originally derived from considerations of the most adverse expected condition. This was taken to correspond to a worker exposed to radioactive material leaking from a package during its transport by road in an enclosed vehicle. The design principle embodied in the Regulations is that radioactive release from a

Type B(U) package should be avoided. However, since absolute containment cannot be guaranteed, the purpose of specifying maximum allowable 'activity leak' rates is to permit the specification of appropriate and practical test procedures which are related to acceptable radiological protection criteria. The model used in the derivation of the release rate of $A_2 \times 10^{-6}$ per hour is discussed in Appendix I.

656.3. The 1973 revised edition (as amended) of the Regulations stipulated that the radiation level at 1 m from the surface of a Type B(U) package should not exceed 100 times the value that existed before the accident condition tests, had the package contained a specified radionuclide. This requirement constituted an unrealistic design constraint in the case of packages designed to carry other radionuclides. Therefore, since the 1985 edition of the Regulations, a specific maximum radiation level of 10 mSv/h has been stipulated, irrespective of radionuclide.

656.4. The release limits of not more than $10 A_2$ for Kr-85 and not more than A_2 for all other radionuclides in a period of one week for Type B(U) packages when subjected to the tests to simulate normal and accident conditions of transport represent a simplification of the provisions of the 1973 edition of the Regulations. This change was introduced in recognition of the fact that the Type B(U) limit appeared unduly restrictive in comparison with safety standards commonly applied at power reactor sites [29, 30], especially for severe accident conditions which are expected to occur only very infrequently. The radiological implications of a release of A_2 from a Type B(U) package under accident conditions have been discussed in detail elsewhere [31]. Assuming that accidents of the severity simulated in the Type B(U) tests specified in the Regulations would result in conditions such that all persons in the immediate vicinity of the damaged package would be rapidly evacuated, or be working under health physics supervision and control, the incidental exposure of persons otherwise present near the scene of the accident is unlikely to exceed the annual dose or intake limits for workers set forth in the BSS. The special provision in the case of Kr-85, which is the only rare gas radionuclide of practical importance in shipments of irradiated nuclear fuel, results from a specific consideration of the dosimetric consequences of exposure to a radioactive plume, for which the models used in the derivation of A_2 values for non-gaseous radionuclides are inappropriate [32].

656.5. The Regulations require Type B(U) packages to be designed to restrict loss of radioactive contents to an acceptably low level. This is specified as a permitted release of radioactive material expressed as a fraction of A_2 per unit time for normal and accident conditions of transport. These criteria have the advantage of expressing the desired containment performance in terms of the parameter of primary interest: the potential hazard of the particular radionuclide in the package. The disadvantage of this method is that direct measurement is generally impractical and it is required to

be applied to each individual radionuclide in question in the physical and chemical form which is expected after the mechanical, thermal and water immersion tests. It is more practical to use well established leakage testing methods such as gas leakage tests; see ANSI N14.5 [27] and ISO 12807 [28]. In general, leakage tests measure material flow passing a containment boundary. The flow may contain a tracer material such as a gas, liquid, powder or the actual or surrogate contents. A means should therefore be determined to correlate the measured flow with the radioactive material leakage expected under the reference conditions. This radioactive material leakage can then be compared with the maximum radioactive material leakage rate that is permitted by the Regulations. If the tracer material is a gas, the leakage rate expressed as a mass flow rate can be determined. If the tracer material is a liquid, either the leakage rate, expressed as a volumetric flow rate, or the total leakage expressed as a volume can be determined. If the tracer material is a powder, the total leakage, expressed as a mass, can be determined. Finally, if the tracer material is radioactive, the leakage expressed as an activity can be determined. Volumetric flow rates for liquids and mass flow rates for gases can be calculated by the use of established equations. If powder leakage is calculated by assuming that the powder behaves as a liquid or an aerosol, the result will be very conservative.

656.6. The basic method of calculation therefore involves the knowledge of two parameters: the radioactive concentration of the contents of the package, and its volumetric leakage rate. The product of these two parameters should be less than the maximum permitted leakage rate expressed as a fraction of A_2 per unit time.

656.7. For packages containing radioactive materials in liquid or gaseous form, the concentration of the radioactivity is to be determined in order to convert Bq/h (activity leakage rate) to m^3/s (volumetric leakage rate) under equivalent transport conditions. When the contents include mixtures of radionuclides (R1, R2, R3, etc.), the ‘unity rule’ specified in para. 404 is used as follows:

$$\frac{\text{Potential release of R1}}{\text{Allowable release of R1}} + \frac{\text{Potential release of R2}}{\text{Allowable release of R2}} + \frac{\text{Potential release of Rn}}{\text{Allowable release of Rn}} \leq 1$$

656.8. From this, and assuming uniform leakage rates over the time intervals being considered, the activity of the gas or liquid in the package and the volumetric leakage rate are required to fulfil the following conditions:

For the conditions in para. 656(a),

$$\sum_i \frac{C_{(Ri)}}{A_{2(Ri)}} \leq \frac{10^{-6}}{3600 \text{ L}} = \frac{2.78 \times 10^{-10}}{\text{L}}$$

For the conditions in para. 656(b)(ii),

$$\sum_i \frac{C_{(Ri)}}{A_{2(Ri)}} \leq \frac{1}{7 \times 24 \times 3600 \text{ L}} = \frac{1.65 \times 10^{-6}}{\text{L}}$$

where

$C_{(Ri)}$ is the concentration of each radionuclide in TBq/m³ of liquid or gas at standard conditions of temperature and pressure (STP),

$A_{2(Ri)}$ is the limit specified in Table I of the Recommendations in TBq for that nuclide, and

L is the permitted leakage rate in m³/s of liquid or gas at STP.

The quantity C can also be derived as follows:

$$C = GS$$

where

G is the concentration of the radionuclide in kg/m³ of liquid or gas at STP, and

S is the specific activity of the nuclide in TBq/kg of the pure nuclide (see Appendix II), or

$$C = FgS$$

where

F is the fraction of the radionuclide present in an element (percentage/100), and

g is the concentration of the element in kg/m³ of liquid or gas at STP.

656.9. Note that the allowable activity release after tests for normal conditions of transport is given in terms of TBq/h and after tests for accident conditions in terms of TBq/week. It is unlikely that any leakage after an accident will be at a uniform rate. The value of interest is the total leakage per week and not the rate at any time during the week (i.e. the package may leak at a high rate for a short period of time following exposure to the accident environment and then release essentially nothing for the remainder of the week as long as the total release does not exceed A_2 per week).

656.10. The calculated permitted leakage of radioactive liquid or gas may then be converted to an equivalent test gas leakage under reference conditions, taking account of pressure, temperature and viscosity by means of the equations for laminar and/or molecular flow conditions, examples of which are given in American National Standard ANSI N14.5-1977 [27] or ISO (DIS) 12807 [28]. In particular cases where a high differential pressure may result in a high permitted gas velocity, turbulent flow may be the more limiting quantity and should be taken into account.

656.11. The test gas leakage determined by the above method may range from about $1 \text{ Pa}\cdot\text{m}^3/\text{s}$ to less than $10^{-10} \text{ Pa}\cdot\text{m}^3/\text{s}$, depending upon the A_2 values of the radionuclides and their concentration in the package. Generally in practice, a test need not be more sensitive than $10^{-8} \text{ Pa}\cdot\text{m}^3/\text{s}$ for a pressure difference of $1 \times 10^5 \text{ Pa}$ to qualify a package as being leaktight. Where the estimated allowable test leakage rate exceeds $10^{-2} \text{ Pa}\cdot\text{m}^3/\text{s}$, a limiting value of $10^{-2} \text{ Pa}\cdot\text{m}^3/\text{s}$ is recommended because it is readily achievable in practical cases.

656.12. When a package is designed to carry solid particulate material, test data on the transmission of solids through discrete leak paths or seals can be used to establish test gas conditions. This will generally give a higher allowed volumetric leakage rate than assuming that the particulate material behaves as a liquid or an aerosol. In practice even the smallest particle size powder would not be expected to leak through a seal which has been tested with helium to better than $10^{-6} \text{ Pa}\cdot\text{m}^3/\text{s}$ with a pressure difference of $1 \times 10^5 \text{ Pa}$.

656.13. In a package design, maximum radiation levels are established both at the surfaces (paras 531 and 532) and at 1 m from the surfaces of the package (as implied by paras 530 and 526). After the tests for accident conditions have been performed, however, an increase in the radiation level is allowed provided that the limit of 10 mSv/h at 1 m from the surface is not exceeded when the package is loaded with its maximum allowed activity.

656.14. When shielding is required for a Type B(U) package design, the shielding may consist of a variety of materials, some of which may be lost during the tests for accident conditions. This is acceptable provided that the radioactive contents remain in the package and sufficient shielding is retained to ensure that the radiation level at 1 m from the 'new' (after test) external surface of the package does not exceed 10 mSv/h .

656.15. The demonstration of compliance with this acceptance criterion of not more than 10 mSv/h at 1 m from the external surface of a Type B(U) package after the applicable tests may be made by different means: calculations, tests on models, parts or components of the package, tests on prototypes, etc., or by a combination of them. In verifying compliance, attention should be paid to the potential for increased localized radiation levels emanating through cracks or gaps which could appear as a defect of design or manufacturing or could occur during the tests as a consequence of the mechanical or thermal stresses, particularly in drains, vents and lids.

656.16. When the verification of compliance is based on full scale testing, the evaluation of the loss of shielding may be made by putting a suitable radioactive source into the specimen and monitoring entirely the outside surface with an appropriate

detector, for instance films, Geiger–Müller probes or scintillation probes. For thick shields a scintillation probe, e.g. thallium activated NaI of small diameter (about 50 mm), is usually employed because it allows the use of low activity sources, typically Co-60, and because its high sensitivity and small effective diameter permits an easy and effective detection of increased localized radiation levels. If measurements are made near the surface of the packaging, care must be taken to properly measure (see para. 233.5) the radiation level and to average the results (see para. 233.6). Calculations will then be needed to adjust the measured radiation level to 1 m from the external surface of the package. Finally, unless the radioactive contents for which the package is designed are used in the test, further calculations will be required to adjust the measured values to those which would have existed had the design contents been used.

656.17. The use of lead as a shielding material needs special care. Lead has a low melting temperature and high coefficient of expansion and, therefore, it should be protected from the effects of the thermal test. If it is contained in relatively thin steel cladding which could be breached in the impact test and if the lead melts in the fire, it would escape from the package. Also, owing to its high coefficient of expansion the lead could burst the cladding in the thermal test and be lost. In both these cases the radiation level could be excessive after the thermal test. To overcome the expansion problem, voids might be left to allow the lead to expand into them, but it should be recognized that, when the lead cools, a void will exist whose position may be difficult to predict. A further problem is that uniform melting of the lead may not necessarily occur, owing to non-uniformities in packaging structure and in the fire environment. In this event, localized expansion could result in the cladding being breached and the subsequent loss of lead, thus reducing the shielding capability of the package.

656.18. Additional guidance on testing the integrity of radiation shielding may be found in the literature [33–38].

656.19. Packages designed for the transport of irradiated fuel pose a particular problem in that the activity is concentrated in fission products in fuel pins which have been sealed prior to irradiation. Pins which were intact on loading into the package would generally be expected to retain this activity under normal conditions of transport.

656.20. Under accident conditions of transport, irradiated fuel pins may fail, with subsequent radioactive release into the package containment system. Data on the fuel fission product inventory, possible failure rate of pin cladding and the mechanism of activity transfer from the failed pin into the containment system are therefore required to enable the package leaktightness to be assessed.

656.21. The above methods of assessing the leaktightness requirements of packages are generally applied in two ways:

- (a) When the package is designed for a specific function, the radioactive contents are clearly defined and the standard of leaktightness can be established at the design stage.
- (b) When an existing package with a known standard of leaktightness is required to be used for a purpose other than that for which it was designed, the maximum allowable radioactive material contents have to be determined.

656.22. In the case of a mixture of radionuclides leaking from a Type B(U) package, an effective A_2 may be calculated by the method of para. 404, using the fractional activities of the constituent radionuclides $f(i)$ that are appropriate to the form of mixture which can actually leak through the seals. This is not necessarily the fraction within the package itself since part of the contents may be in solid discrete pieces too large to pass through seal gaps. In general, for leakage of liquids and gases the fractional quantities relate to the gaseous or dissolved radionuclides. Care is necessary, however, to take account of finely divided suspended solid material.

656.23. If the package has elastomeric seals, permeation of gases or vapours may cause relatively high leakage rates. Permeation is the passage of a liquid or gas through a solid barrier (which has no direct leak paths) by an absorption–diffusion process. Where the radioactive material is gaseous (e.g. fission gas), the rate of permeation leakage is determined by the partial pressure of the gas and not by the pressure in the containment system. The tendency of elastomeric materials to absorb gases can also be taken into account.

656.24. It should be noted that, in the case of some large packages, very small leakage of radioactive material over a long time period could result in contamination of the exterior surface. In these cases it may be necessary to reduce the leakage under normal conditions of transport (para. 656(a)) to ensure that the surface contamination limit (paras 214, 508 and 509) is not exceeded.

657.1. Various risk assessments have been carried out over the years for the sea transport of radioactive materials, including those documented in the literature [39, 40]. These studies consider the possibility of a ship carrying packages of radioactive material sinking at various locations; the accident scenarios include a collision followed by sinking, or a collision followed by a fire and then followed by sinking.

657.2. In general it was found that most situations would lead to negligible harm to the environment and minimal radiation exposure to persons if the packages were not

recovered following the accident. It was found, however, that, should a large irradiated fuel package (or packages) be lost on the continental shelf, some long term exposure to persons through the ocean food chain could occur. The radiological impact from loss of irradiated fuel packages at greater depths or of other radioactive material packages at any depth was found to be orders of magnitude lower than these values. Later studies have considered the radiological impact from the loss of other radioactive materials which are increasingly being transported in large quantity by sea, such as plutonium and high level radioactive waste. On the basis of these studies, the scope of the enhanced water immersion test requirement has been extended in the 1996 edition of the Regulations to cover any radioactive material transported in large quantity, not only irradiated nuclear fuel.

657.3. In the interest of keeping the radiological impacts as low as reasonably achievable should such an accident occur, the requirement for a 200 m water submersion test for irradiated fuel packages containing more than 37 PBq of activity was originally added to the 1985 edition of the Regulations. In this edition the threshold defining 'large quantity' has been amended to a multiple of A_2 , which is considered a more appropriate criterion to cover all radioactive materials, being based on a consideration of external and internal radiation exposure to persons as a result of an accident. The 200 m depth corresponds approximately to the continental shelf and to the depths where the above mentioned studies indicated radiological impacts could be important. Recovery of a package from this depth would be possible and often would be desirable. Although the influence of the expected radioactive release into the environment would be acceptable, as shown by the risk assessments, the requirement in para. 657 was imposed because salvage would be facilitated after the accident if the containment system were not ruptured, and therefore only retention of solid contents in the package was considered necessary. The specific release rate requirements imposed for other test conditions (see para. 656) are therefore not applied here.

657.4. In many cases of Type B(U) package design, the need to meet other sections of the Regulations will result in a containment system which is completely unimpaired by immersion in 200 m of water.

657.5. In cases in which the containment efficiency is impaired, it is recognized that leakage into the package and subsequent leakage from the package is possible.

657.6. The aim under conditions of an impaired containment should be to ensure that only dissolved radioactive material is released. Retention of solid radioactive material in the package reduces the problems in salvaging the package.

657.7. Degradation of the total containment system could occur with prolonged immersion, and the recommendations made in the above paragraphs should be considered as being applicable, conservatively, for immersion periods of about one year, during which recovery should readily be completed.

658.1. The increase in design complexity and any additional uncertainty and possible unreliability associated with filters and mechanical cooling systems are not consistent with the philosophy underlying the Type B(U) designation (unilateral competent authority approval). The simpler design approach where neither filters nor cooling systems are used has a much wider acceptability.

660.1. Subsequent to the closure of a package the internal pressure may rise. There are several mechanisms which could contribute to such a rise, including exposure of the package to a high ambient temperature, exposure to solar heating (i.e. insolation), heat from the radioactive decay of the contents, chemical reaction of the contents, radiolysis in the case of water filled designs, or combinations thereof. The maximum value which the summation of all such potential pressure contributors can be expected to produce under normal operating conditions is referred to as the maximum normal operating pressure (MNOP) — see paras 228.1–228.3.

660.2. Such a pressure could adversely affect the performance of the package and consequently needs to be taken into account in the assessment of performance under normal operating conditions.

660.3. Similarly, in the assessment of the ability to withstand accident conditions (paras 726–729) the presence of a pre-existing pressure could present more onerous conditions against which satisfactory package performance must be demonstrated — consequently, the MNOP needs to be assumed in defining the pre-test condition (see paras 228.1 and 228.2). If justifiable, pressures different from the MNOP may be used provided the results are corrected to reflect the MNOP.

660.4. Type B(U) packages are generally not pressure vessels and do not fit tidily within the various codes and regulations which cover such vessels. For the tests required to verify the ability of a Type B(U) package to withstand both normal and accident conditions of transport, assessment under the condition of MNOP is required. Under normal transport conditions, the prime design considerations are to provide adequate shielding and to restrict radioactive leakage under quite modest internal pressures. The accident situation represents a single extreme incident following which reuse is not considered as a design objective. Such an extreme incident is characterized by single short duration, high stress cycles during the mechanical tests at normal operating temperature, followed by a single, long duration stress cycle

induced by the temperatures and pressures created during the thermal test. Neither of these stress cycles fit the typical pattern of loading of pressure vessels, the design of which is concerned with time dependent degradation processes such as creep, fatigue, crack growth and corrosion. For this reason, specific reference to the allowable stress levels has not been included in the Regulations. Instead, strains in the containment system are restricted to values which will not affect its ability to meet the applicable requirements. Whilst other requirements might eventually assume importance, it is for the containment of radioactive material that the containment system exists. Before a fracture would occur it is likely that containment systems, particularly in reusable packagings with mechanically sealed joints, will leak. The extent to which the strains in the various components distort the containment system and impair its sealing integrity should therefore be determined. Reduction of seal compression brought about, for example, by bolt extensions and local damage due to impact and by rotations of seal faces during thermal transients need to be assessed. One assessment technique is to predict the distortions on impact directly from drop tests on representative scale models and to combine these with the distortions calculated to arise during the thermal test using a recognized and validated computer code. The effects upon sealing integrity of the total distortion may then be determined by experiments on representative sealed joints with appropriately reduced seal compressions.

660.5. The MNOP should be determined in accordance with the definition given in para. 228.

660.6. It is recommended that the strains in a containment system under normal conditions of transport at maximum normal operating pressure should be within the elastic range. The strains under accident conditions of transport should not exceed the strains which would allow leakage rates greater than those stated in para. 656(b), nor increase the external surface radiation level beyond the requirements of para. 656.

660.7. When analysis is used to evaluate package performance, the MNOP should be used as a boundary condition for the calculation of the effect of the tests for demonstrating ability to withstand normal conditions of transport and as an initial condition for the calculation of the effect of the tests for demonstrating ability to withstand accident conditions of transport.

661.1. The requirement that the MNOP not exceed 700 kPa gauge is the specified limit for Type B(U) packages to be acceptable for unilateral approval.

662.1. The surface temperature limit of 85°C for Type B(U) packages under exclusive use, where potential damage to adjacent cargo can be well controlled, is required

to prevent injury to persons from casual contact with packages. When exclusive use does not apply, or for all air transport, the surface temperature is limited to 50°C to avoid potential heat damage to adjacent cargo. The barriers or screens referred to in para. 662 are not regarded as part of the package design from the standpoint of radiological safety; therefore, they are excluded from any tests associated with package design.

662.2. Insolation may be ignored with regard to the temperature of accessible surfaces and account is taken only of the internal heat load. The justification for this simplification is that any package, with or without internal heat, would experience a similar surface temperature increase when subjected to insolation.

662.3. Readily accessible surface is not a precise description, but is interpreted here to mean those surfaces which could be casually contacted by a person who may not be associated with the transport operation. For example, the use of a ladder might make surfaces accessible, but this would not be cause for considering the surfaces as readily accessible. In the same sense, surfaces between closely spaced fins would not be regarded as readily accessible. If fins are widely spaced, say the width of a person's hand or more, then the surface between the fins could be regarded as readily accessible.

662.4. Barriers or screens may be used to give protection against higher surface temperatures and still retain the Type B(U) approval category. An example would be a closely finned package fitted with lifting trunnions where the use of the trunnions would require the fins to be cut away locally to the trunnions and thus expose the main body of the package as an accessible surface. Protection may be achieved by the use of a barrier, such as an expanded metal screen or an enclosure which effectively prevents access or contact with the package by persons during routine transport. Such barriers would then be considered as accessible surfaces and would thus be subject to the applicable temperature limit. The use of barriers or screens should not impair the ability of the package to meet heat transfer requirements nor reduce its safety. Such a screen or other device is not required to survive the regulatory tests for the package design to be approved. This provision permits approval of packages using such thermal barriers without the barriers having to be subjected to the tests which the package is required to withstand.

663.1. Special attention should be given to the interaction between the low dispersible radioactive material and the packaging during normal and accident conditions of transport. This interaction should not damage the encapsulation, cladding or other matrix nor cause comminution of the material itself to a degree that would change the characteristics as demonstrated by the requirements of para. 605.

664.1. The lower temperature is important because of pressure increases from materials which expand upon freezing (e.g. water), because of possible brittle fracture of many metals (including some steels) at reduced temperature and because of possible loss of resilience of seal materials. Of these effects, only fracture of materials could lead to irreversible damage. Some elastomers which provide good high temperature performance (e.g. fluorocarbons, such as Viton compounds) lose their resilience at temperatures of -20°C or less. This can lead to narrow gaps of some micrometres in width arising from differential thermal expansion between the metal components and the elastomer. This effect is fully reversible. In addition, freezing of any humid contents and internal pressure drop at the low temperatures could prevent leakage from the containment. Therefore in certain cases the use of such elastomeric seals could be accepted; see Refs [41, 42] for further information. The lower temperature limit of -40°C and the upper temperature limit of 38°C are reasonable bounding values for ambient temperatures which could be experienced during transport of radioactive material in most geographical regions at most times of the year. However, it must be recognized that in certain areas of the world (extreme northern and southern regions during their winter periods and dry desert regions during their summer periods) temperature extremes below -40°C and above 38°C are possible. Averaged over area and time, however, temperatures falling outside the range -40 to 38°C are expected to occur during only a small fraction of the time.

664.2. See Appendix VI for Guidelines for Safe Design of Shipping Packages against Brittle Fracture.

664.3. In assessing a package design for low temperature performance, the heating effect of the radioactive contents (which could prevent the temperatures of package components from falling to the minimum limiting ambient design temperature of -40°C) should be ignored. This will allow package response (including structural and sealing material behaviour) at the low temperature to be evaluated for handling, transport and in-transit storage conditions. Conversely, in evaluating a package design for high temperature performance, the effect of the maximum possible heating by the radioactive contents, as well as insolation and the maximum limiting ambient design temperature of 38°C , should be considered simultaneously.

REQUIREMENTS FOR TYPE B(M) PACKAGES

665.1. The intent is that the safety standards of Type B(M) packages, so designed and operated, provide a level of safety equivalent to that provided by Type B(U) packages.

665.2. Departures from the requirements given in paras 637, 653, 654 and 657–664 are acceptable, in some situations, with the agreement of the pertinent competent authority(ies). An example of this could be a reduction in the ambient temperature range and insolation values taken for design purposes if the Type B(U) requirements are not considered applicable (paras 637, 653, 654 and 664), or making allowance for the heating effect of the radioactive contents.

666.1. For the contents of some packages, as a result of the mechanisms described in para. 660.1, the pressure tends to build up and, if not relieved, might eventually cause failure of the package, or reduce the useful lifetime of the package through fatigue. To avoid this, para. 666 allows the package design to include a provision for intermittent venting. Such vented packages are required by the Regulations to be shipped as Type B(M) packages.

666.2. In order to provide safety equivalent to that which would be provided by a Type B(U) package, the design may include requirements that only gaseous materials should be allowed to be vented, that filters or alternative containment might be used, or that venting may only be performed under the direction of a qualified health physicist.

666.3. Intermittent venting is permitted in order to allow a package to be relieved of a buildup of pressure which might, under normal conditions of transport (see paras 719–724) or when the package is subjected to the thermal test (see para. 728), cause it to fail to meet the Regulations. Radioactive release under normal conditions and under accident conditions, where no operational controls are used, is limited, however, by the provisions of para. 656.

666.4. Because there is no specified regulatory limit of radioactive release for intermittent venting, where operational controls are used the person responsible should be able to demonstrate to the competent authority, using a model which relates as closely as possible to the actual conditions of package venting, that transport workers and members of the public will not be exposed to doses in excess of those laid down by the relevant national authorities. When the intermittent venting operation is taking place under the control of a radiation protection adviser, the release may be varied on his or her advice, with account taken of measurements made during the operation to assure that workers and members of the public are adequately protected.

666.5. Factors taken into account in such an assessment will include:

- (a) Exposure due to normal radioactive leakage and external radiation from the package;

- (b) The location and orientation of the venting orifice in relation to the working position of the operator and the proximity of workers and members of the public;
- (c) Occupancy factors of workers and members of the public;
- (d) The physical and chemical nature of the material being vented, e.g. gaseous (halogen, inert gas, etc.), particulate, soluble/insoluble; and
- (e) Other dose commitments incurred by operators and the public.

666.6. In assessing the adequacy of the release operation, account should be taken of possible detriment from retaining and disposing of the released radioactive material rather than allowing it to disperse.

REQUIREMENTS FOR TYPE C PACKAGES

667.1. Analogous to a Type B(U) or Type B(M) package, the concept of a Type C package is that it is capable of withstanding severe accident conditions in air transport without loss of containment or increase in external radiation level to an extent that would endanger the general public or those involved in rescue or cleanup operations. The package could be safely recovered, but it would not necessarily be capable of being reused.

668.1. One of the potential post-crash environments is package burial. Packages involved in a high velocity crash may be covered by debris or buried in soil. If packages whose contents generate heat become buried, an increase in package temperature and internal pressure may result.

668.2. To make this analysis, the initial condition of the package is taken as it is designed to be presented for transport.

668.3. Demonstration of compliance with the performance standards under burial conditions should be made using conservative calculations or validated computer codes. The evaluation of the condition of a buried package should take into account the integrity of both the shielding and the containment system, according to the requirements specified in para. 669(b) as well as the requirement of para. 668 that the thermal insulation be considered intact. For this reason, special attention should be given to heat dissipation capability and the change in the internal pressure in the burial condition.

669.1. The Type C package provides similar levels of protection for the air mode when compared to a Type B(U) or Type B(M) package in a severe surface mode

accident. To achieve this goal, it is necessary to ensure that the same external radiation level and loss of contents limits are required following the Type B accident condition and the Type C tests.

669.2. See also para. 656 for further explanatory material on requirements for dose limits and material release limits.

669.3. The text in paras 656.1–656.24 also applies to Type C packages.

670.1. Because a Type C package may be immersed in a lake, inland sea, or on the continental shelf where recovery is possible, the enhanced immersion test is required for all Type C packages regardless of the total activity in the package.

670.2. In an air accident over a body of water, a package could be submerged for a period of time pending recovery. Large hydrostatic pressures could be applied to the package, depending upon the depth of submersion. Of primary concern is the possible rupture of the containment system. An additional consideration is recovery of the package before severe corrosion develops.

670.3. The 200 m depth required corresponds approximately to the maximum depth of the continental shelf. Recovery of a package from this depth would be possible and desirable. The acceptance criterion for the immersion test is that there is no rupture of the containment system. Further advice may be found in paras 657.2, 657.3 and 657.5–657.7.

670.4. As the sea represents a softer impact surface than land, it is sufficient that the immersion test be an individual demonstration requirement, that is, non-sequential to other tests.

REQUIREMENTS FOR PACKAGES CONTAINING FISSILE MATERIAL

671.1. The requirements for packages containing fissile material are additional requirements imposed to ensure that packages with fissile material contents will remain subcritical under normal and accident conditions of transport. All other relevant requirements of the Regulations must be met. The system for implementing criticality control in transport is prescribed in Section V of the Regulations.

671.2. Packages containing fissile material are required to be designed and transported in such a way that an accidental criticality is avoided. Criticality is achieved when the fission chain reactions become self-supported due to the balance between

the neutron production and the neutron loss by absorption in and leakage from the system. Package design involves consideration of many parameters that influence neutron interaction (see Appendix VII). The criticality safety assessment must consider these various parameters and ensure that the system will remain subcritical in both normal and accident conditions of transport. Assessments should be performed by qualified persons experienced in the physics of criticality safety. In addition to the obvious control of fissile material mass, the package designer may influence criticality control by any of the following methods:

- (i) Selection of the shapes for the confinement system or packaging influences neutron leakage from fissile units by altering the surface-to-volume ratio. For example, thin cylinders or slabs have increased neutron leakage in comparison with spheres or cylinders with a height-to-diameter ratio near unity.
- (ii) Selection of packaging material influences the number of leaking neutrons that are reflected back into the fissile material. The number of neutrons returned (or leaving) and their energies are determined to a large extent by the selection of the packaging material.
- (iii) Selection of external package dimensions: Neutrons leaking from a package containing fissile material may enter other fissile packages and produce a fission event. Neutron interaction can be influenced by the package dimensions, which determine the spacing of the fissile material and can be adjusted to limit interaction between different units of fissile material.
- (iv) Use of fixed neutron absorbers to remove neutrons (see para. 501.8).
- (v) Selection of package design to control the ratio of moderating material to fissile material, including the reduction of void space to limit the amount of water that may leak into a package.

671.3. The contingencies required to be considered in the assessment of a package presented for shipment, as itemized in para. 671(a), could influence the neutron multiplication of the package or array of packages. These contingencies are typical ones that may be important and should be carefully considered in the assessments. However, depending on the package design and any special conditions anticipated in transport or handling, other atypical contingencies may need to be considered to ensure that subcriticality is maintained under all credible transport conditions. For example, if the test results show movement of the fissile or neutron absorber material in the package, the uncertainty limits that bound this movement should be considered in the criticality safety assessments. It should be borne in mind that the prototype used in testing may vary from the production models in detail, in manufacturing method and in manufacturing quality. The as-built dimensions of the prototype may need to be known to examine the effect of tolerances on the tests. The difference between tested models and production models needs to be considered.

The goal is to obtain the maximum credible neutron multiplication such that subcriticality is assured.

671.4. Water influences criticality safety in several ways. When it is mixed with fissile material the resulting neutron moderation can significantly reduce the amount of fissile material required to achieve criticality. As a reflector of neutrons, water also increases the neutron multiplication factor, though less dramatically. If the water reflector is located outside the confinement system, it is less effective, and less still outside the package. Thick layers of full density water (~30 cm) between packages can reduce neutron interaction in arrays to an insignificant value [43, 44]. The criticality assessment should consider the changes in package geometry or conditions that might cause water to behave more as a moderator than a reflector, or vice versa. All forms of water should be considered, including snow, ice, steam, vapour and sprays. These low density forms of water often produce (particularly in considering interstitial water between packages) a neutron multiplication higher than that seen with full density water (see Appendix VII).

671.5. Neutron absorbers are sometimes employed in the packaging to reduce the effect of moderation and the contribution to the neutron multiplication resulting from interaction among packages (see para. 501.8). Typical neutron absorbing materials used for criticality control are most effective when a neutron moderator is present to reduce the neutron energy. The loss of effectiveness of neutron absorbers, e.g. by corrosion and redistribution, or, as in the case of contained powders, by settling, can have a marked effect on the neutron multiplication factor.

671.6. Paragraphs 671(a)(iii) and (iv) address contingencies arising from dimensional changes or movement of the contents during transport. Feasible rearrangements of the packaging or contents are required to be considered in establishing the margin of subcriticality. Changes to the package dimensions due to the normal or accident tests must be of concern to the package evaluator. Indications of dimension changes during the accident tests should cause the evaluator to assess the sensitivity of these changes to the neutron multiplication. A loss of the fissile material from the array of packages considered in the evaluation of para. 682 must be limited to a subcritical quantity. This subcritical quantity should be consistent with the type of contents and with optimum water moderation and reflection by 20 cm of full density water. The reduction of spaces between packages, credible because of possible damage to the package in transport, will have a direct effect on the neutron interaction among packages; thus, it requires examination. The effect on reactivity of tolerances on dimensions and material compositions should be considered. It is not always obvious whether particular dimensions or compositions should be maximized or minimized or how, in combination, they affect reactivity. A number of calculations may need to be performed in order that the

maximum reactivity of the system can be determined or an appropriate allowance for these contingencies can be developed.

671.7. The effects of temperature changes (para. 671(a)(vi)) on the stability of fissile material form or on the neutron interaction properties are required to be examined. For example, uranium systems dominated by very low energy (thermal) neutrons have an increase in neutron multiplication as the temperature is reduced. Temperature changes may also influence the package integrity. The temperatures which should be considered include those resulting from ambient condition requirements specified in para. 676 and those of the tests (paras 728 or 736, as appropriate).

Exceptions from the requirements for packages containing fissile material

672.1. Packages containing fissile material which meet any of the requirements in paras 672(a)–(d) are excepted from the criticality safety assessment specified in para. 671(b). Assurance that the excepted criteria are met for both the individual package and the consignment is the responsibility of the consignor of the excepted material.

672.2. The origin of the limits in para. 672(a)(i) is based on the work of Woodcock and Paxton [45], where a minimum container volume of 1 L and a maximum limit of 250 packages were used to obtain fissile material limits of 9.4 g for Pu-239, 16.0 g for U-233 and 16.2 g for U-235 for individual packages. Practical considerations (consistency and the fact that the A_2 value for Pu-239 would cause gram quantities to be transported as special form radioactive material or in a Type B packaging) caused the limit to be subsequently changed [46] to a uniform value of 15 g. In para. 672(a)(ii) the minimum critical concentration for Pu-239 is 7.5 g/L, and approximately 12 g/L for U-235 and U-233 for water moderated systems [47]. These values correspond, respectively, to fissile-to-hydrogen mass ratios of approximately 6.7% and 10.8%. Thus, hydrogenous mixtures with less than a 5% fissile-to-hydrogen mass ratio have an adequate subcritical safety margin. Although use of a mass ratio in the exception criteria may be more cumbersome than a concentration value (as used in previous editions of the Regulations), this formulation is a better measure for hydrogenous mixtures other than water.

672.3. Paragraph 672(a)(iii) facilitates the safe transport of contaminated waste containing fissile material at a very low concentration.

672.4. The safety considerations underlying the three exceptions in para. 672(a) are based upon the assumption of hydrogenous moderation and reflection; thus a restriction on the presence of the potentially more effective elements beryllium and deuterium is applied.

672.5. Each of the exceptions provided by para. 672(a) is further restricted by an allowed mass limit per consignment. The formula for the mass limit allows for mixing of fissile material, but the formula and the values provided in Table XII are set such that the maximum consignment mass is no more than approximately half a critical mass value. Thus, the exception criteria provide two points of control (individual package and consignment) to prevent the accumulation of fissile material into quantities that might lead to potential criticality.

672.6. The 1% enriched U-235 limit of para. 672(b) is a rounded value slightly lower than the minimum critical U-235 enrichment for infinite homogeneous mixtures of uranium and water published by Paxton and Pruvost [47]. The homogeneity addressed in para. 672(b) is intended to preclude latticing of slightly enriched uranium in a moderating medium. There is agreement that homogeneous mixtures and slurries are those in which the particles in the mixture are uniformly distributed and have a diameter no larger than $127\ \mu\text{m}$ [48, 49], i.e. not capable of passing through a 120 mesh screen. Concentrations can also vary throughout the material; however, variations in concentration of the order of 5% should not compromise criticality safety.

672.7. The exception limit for para. 672(c) provides for uranyl nitrate solution to have a content enriched in U-235 to not more than 2% by mass of uranium. This limit is slightly lower than the minimum critical enrichment value reported by Paxton and Pruvost [47].

672.8. Paragraph 672(d) sets a 1 kg limit for shipments of plutonium containing no more than 20% by weight of Pu-239 and Pu-241. Subcriticality in the transport of this quantity of plutonium is assured by virtue of the Type B(U) or Type B(M) packages, which provide adequate separation from other fissile material, and because the plutonium composition is not amenable to criticality in thermal fissioning systems. (Monte Carlo analyses indicate 6.8 kg of material with 80% Pu-238 and 20% Pu-239 by weight is needed for the critical mass of a fully water reflected metal sphere [50].)

672.9. The exceptions provided in para. 672 were originally conceived to ensure that incredible conditions would have to occur for the excepted packages on a conveyance to cause a criticality accident. Besides the accumulation of sufficient mass of fissile material on a conveyance, the material would have to be subsequently rearranged within an appropriate moderating material to obtain the density and form required for a critical system. Where necessary the exceptions provide limits on the consignment to preclude the accumulation of critical mass. Shippers and competent authorities should be alert to potential abuses of the exception limits that might give rise to a potential for criticality.

672.10. Other data to support the exceptions limits provided in para. 672 can be found in the literature [50–53].

Contents specification for assessments of packages containing fissile material

673.1. Values of unknown or uncertain parameters should be appropriately selected to produce the maximum neutron multiplication factor for the assessments performed as described in paras 671–682. In practice, this requirement may be met by covering the effect of these uncertainties by a suitable allowance in the acceptance criteria. Mixtures whose contents are not well defined are often generated as by-products of production operations, e.g. contaminated work clothes, gloves or tools, residues of chemical analyses and operations, floor sweepings, and as direct products from waste processing operations. It is important to determine the combination of parameters that produces the maximum neutron multiplication. Thus, the criticality safety assessment must both identify the unknown parameters and explain the interrelationship of the parameters and their effects on neutron multiplication. The range of values possible (based on available information and consistent with the nature of the material involved) should be determined for each parameter, and the neutron multiplication factor for any possible combination of parameter values should be shown to satisfy the acceptance criteria. This principle should also be applied to the irradiation characteristics used to determine the isotopics for irradiated nuclear fuel.

674.1. The requirements for the criticality assessment of irradiated nuclear fuel are addressed in this paragraph. The major objective is to ensure that the radionuclide contents used in the safety assessment provide a conservative estimate of the neutron multiplication in comparison with the actual loading in the package. Irradiation of fissile material typically depletes the fissile nuclide content and produces actinides which contribute to neutron production and absorption, and fission products which contribute to neutron absorption. The long term, combined effect of this change in the nuclide composition is to reduce the reactivity from that of the unirradiated state. However, reactor fuel designs that incorporate fixed neutron burnable poisons can experience an increase in reactivity for short term irradiations where the reactivity gain due to depletion of the fixed neutron poisons is greater than the reactivity loss due to the change in the fuel composition. If the assessment uses an isotopic composition that does not correspond to a condition greater than or equal to the maximum neutron multiplication during the irradiation history, then the assumed composition of the fissile material should be demonstrated to provide a conservative neutron multiplication for the known characteristics of the irradiated nuclear fuel as loaded in the package.

674.2. Unless it can be demonstrated in the criticality assessment that the maximum neutron multiplication during the credible irradiation history is provided, a

pre-shipment measurement needs to be performed in order to assure that the fissile material characteristics meet the criteria (e.g. total exposure and decay) specified in the assessment (see para. 502.8). The requirement for a pre-shipment measurement is consistent with the requirement to assure the presence of fixed neutron poisons (see para. 501.8) or removable neutron poisons (see para. 502.4), where required by the package design approval certificate, that are used for criticality control. In the case of irradiated nuclear fuel, the depletion of the fissile radionuclides and the buildup of neutron absorbing actinides and fission products can provide a criticality control that must be assured.

674.3. The maximum neutron multiplication often occurs in the unirradiated state. However, one method of extending the useful residence time of fissile material in a reactor is to add a distributed, fixed neutron burnable poison, allowing a larger initial fissile nuclide content than would otherwise be present. These reactor fuel designs with burnable poisons can experience an increase in reactivity for short term irradiations where the reactivity gain due to depletion of the fixed neutron poisons is greater than the reactivity loss due to the change in the fuel composition. No pre-shipment measurement is required when such fuel is treated in the criticality assessment as both unirradiated and unpoisoned since this will provide a conservative estimate of the maximum neutron multiplication during the irradiation history. The requirements of para. 674(a) apply, therefore, not those of para. 674(b). In addition, breeder reactor fuel and production reactor fuel may have multiplication factors that could increase with irradiation time.

674.4. The evaluation of the neutron multiplication factor for irradiated nuclear fuel must consider the same performance standards as required for unirradiated nuclear fuel (see paras 677–682). However, the assessment for irradiated nuclear fuel must determine the isotopic composition and distribution consistent with the information available on the irradiation history. The radionuclide composition of a particular fuel assembly in a reactor depends, to varying degrees, on the initial radionuclide abundance, the specific power, the reactor operating history (including moderator temperature, soluble boron and reactor assembly location, etc.), the presence of burnable poisons or control rods, and the cooling time after discharge. Seldom, if ever, are all of the irradiation parameters known to the safety analyst. Therefore, the requirements of para. 673 regarding unknown parameters must be considered. The information typically available for irradiated nuclear fuel characterization is the initial fuel composition, the average assembly burnup and the cooling time. Data on the operating history, axial burnup distribution and presence of burnable poisons must typically be based on general knowledge of reactor performance for the irradiated nuclear fuel under consideration. It must be demonstrated that the radionuclide composition and distribution determined using the known and assumed irradiation parameters and

decay time will provide a conservative estimate of the neutron multiplication factor after taking into account biases and uncertainties. Conservatism could be demonstrated by ignoring all or portions of the fission products and/or actinide absorbers or assuming lower burnup than actual. The axial radionuclide distribution of an irradiated fuel assembly is very important because the region of reduced burnup at the ends of an assembly may cause an increased reactivity in comparison to an assembly where the average burnup is assumed for the isotopics over the entire axial height [54–56].

674.5. Calculational methods used to determine the neutron multiplication should be validated, preferably against applicable measured data (see Appendix VII). For irradiated nuclear fuel this validation should include comparison with measured radionuclide data. The results of this validation should be included in determining the uncertainties and biases normally associated with the calculated neutron multiplication. Fission product cross-sections can be important in criticality safety analyses for irradiated nuclear fuel. Fission product cross-section measurements and evaluations over broad energy ranges have not been emphasized to the extent that actinide cross-sections have. Therefore, the adequacy of fission product cross-sections used in the assessment should be considered and justified by the safety analyst.

Geometry and temperature requirements

675.1. This requirement applies to the criticality assessment of packages in normal conditions of transport. The prevention of entry of a 10 cm cube was originally of concern when open, ‘birdcage’ types of packages were permitted. This requirement can now be viewed as providing a criterion for evaluating the integrity of the outer container of the package. Packages exist which have similar features to the birdcage design but whose protrusions beyond the closed envelope (the bird) of the packaging exist not to provide spacing between units in an array, but, for example, as impact limiters. Where no credit is taken for these features in the spacing of units, a 10 cm cube behind or between the protrusions but outside the closed envelope of the packaging should not be considered to have ‘entered’ the package.

676.1. Departure from the temperature range of -40 to 38°C is acceptable in some situations, with the agreement of the competent authority. Where the assessment of the fissile aspects of the package in relation to its response to the regulatory tests would be adversely affected by ambient temperatures, the competent authority should specify in the certificate of approval the ambient temperature range for which the package is approved.

Assessment of an individual package in isolation

677.1. Because of the significant effect water can have on the neutron multiplication of fissile materials, the criticality assessment of a package requires the consideration of water being present in all void spaces within a package to the extent causing maximum neutron multiplication. The presence of water may be excepted from those void spaces protected by special features that must remain watertight under accident conditions of transport. Credible conditions of transport that might provide preferential flooding of packages leading to an increase in neutron multiplication should be considered.

677.2. To be considered 'watertight' for the purposes of preventing in-leakage or out-leakage of water related to criticality safety, the effects of both the normal and accident condition tests need to be considered. Definitive leakage criteria for 'watertightness' should be set in the safety assessment report (SAR) for each package, and accepted by the competent authority. These criteria should be demonstrated to be achieved in the tests, and achievable in the production models.

677.3. The neutron multiplication for packages containing uranium hexafluoride is very sensitive to the amount of hydrogen in the package. Because of this sensitivity, careful attention has been given to restrict the possibility of water leaking into the package. The persons responsible for testing, preparation, maintenance and transport of these packages should be aware of the sensitivity of the neutron multiplication in uranium hexafluoride to even small amounts of water and ensure that the special features defined here are strictly adhered to.

678.1. The part of the package and contents that makes up the confinement system (see para. 209.1) must be carefully considered to ensure that the system includes the portion of the package that maintains the fissile material configuration. Water is specified as the reflector material in the regulations because of its relatively good reflective properties and its natural abundance. The specification of 20 cm of water reflection is selected as a practical value (an additional 10 cm of water reflection would add less than 0.5% in reactivity to an infinite slab of U-235) that is very near the worst reflection conditions typically found in transport. The assessment should consider the confinement system reflected by 20 cm of full density water and with the confinement system reflected by the surrounding material of the packaging. The situation that yields the highest neutron multiplication should be used as the basis for assuring subcriticality. The reason that both situations must be considered is that it is possible that during routine loading operations, or subsequent to an accident, the confinement system could be outside the packaging and reflected by water.

679.1. The requirements for demonstrating subcriticality of an individual package are specified so as to determine the maximum neutron multiplication in both normal and accident conditions of transport. In the assessment, due account must be given to the results of the package tests required in paras 681(b) and 682(b) and the conditions under which the absence of water leakage may be assumed as described in para. 677.

679.2. Note that 'subcritical' means that the maximum neutron multiplication, adjusted appropriately by including a calculational bias, uncertainties and a subcritical margin, should be less than 1.0. See Appendix VII for specific advice on the assessment procedure and advice on determining an upper subcritical limit.

680.1. It is possible for accidents to be significantly more severe in the air mode than in the surface mode. In recognition of this, more stringent requirements have been introduced in the 1996 edition of the Regulations for packages designed for the air transport of fissile material.

680.2. The requirements for packages transported by air address separate aspects of the assessment and apply only to the criticality assessment of an individual package in isolation. Paragraph 680(a) requires a single package, with no water in-leakage, to be subcritical following the Type C test requirements of para. 734. This requirement is provided to preclude a rapid approach to criticality that may arise from potential geometrical changes in a single package; thus, water in-leakage is not considered. Reflection conditions of at least 20 cm of water at full density are assumed as this provides a conservative approximation of reflection conditions likely to be encountered. Since water in-leakage is not assumed, only the package and contents need be considered in the development of the geometric condition of the package following the specified tests. Due credit may be taken in the specification of the geometric conditions in the criticality assessment for the condition of the package following the tests of paras 734(a) and 734(b) on separate specimens of the package. The conditions should be conservative but consistent with the results of the tests. Where the condition of the package following the tests cannot be demonstrated, worst case assumptions regarding the geometric arrangement of the package and contents should be made, taking into account all moderating and structural components of the packaging. The assumptions should be in conformity with the potential worse case effects of the mechanical and thermal tests, and all package orientations should be considered for the analysis. Subcriticality must be demonstrated after due consideration of such aspects as efficiency of moderator, loss of neutron absorbers, rearrangement of packaging components and contents, geometric changes and temperature effects.

680.3. Paragraph 680(b) requires that, for the individual package, water leakage into or out of the package must be addressed unless the multiple water barriers are

demonstrated to be watertight following the tests of paras 734 and 733. Thus, for packages transported by air the tests of para. 682(b) must be replaced with the tests of para. 680(b) in determining watertightness as required by para. 677(a).

680.4. In summary, para. 680(a) provides an additional assessment for a package transported by air while para. 680(b) provides a supplement to para. 677(a) to be applied in the assessment of para. 679 for packages transported by air.

Assessment of package arrays under normal conditions of transport

681.1. The assessment requires that all arrangements of packages be considered in the determination of the number of 5N packages that is subcritical because the neutron interaction occurring among the packages of the array may not be equal along the three dimensions.

681.2. The assessment might involve the calculation of large finite arrays for which there is a lack of experimental data. Therefore a specific supplementary allowance should be made in addition to other margins usually allowed for random and systematic effects on calculated values of the neutron multiplication factor.

681.3. Note that ‘subcritical’ means that the maximum neutron multiplication, adjusted appropriately by including a calculational bias, uncertainties and a subcritical margin, should be less than 1.0. See Appendix VII for specific advice on the assessment procedure and advice on determining an upper subcritical limit.

Assessment of package arrays under accident conditions of transport

682.1. With the 1996 edition of the Regulations, tests for the accident conditions of transport must consider the crush test of para. 727(c) for light weight (<500 kg) and low density (<1000 kg/m³) packages. The criteria for invoking the crush test as opposed to the drop test of para. 727(a) is the same as that used for packages with contents greater than 1000 A₂ not as special form (see para. 656(b)).

682.2. Paragraph 682(c) provides a severe restriction on any fissile material permitted to escape the package under accident conditions. All precautions to preclude the release of fissile material from the containment system should be taken. The variety of configurations possible for fissile material escaping from the containment system and the possibility of subsequent chemical or physical changes require that the total quantity of fissile material that escapes from the array of packages should be less than the minimum critical mass for the fissile material type and with optimum moderator conditions and reflection by 20 cm of full density water. An equal amount of

material should be assumed to escape from each package in the array. The difficulty is in demonstrating the maximum quantity that could escape from the containment system. Depending on the packaging components that define the containment and confinement systems, it is possible for fissile material to escape the containment system, but not the confinement system. In such cases there may be adequate mechanisms for criticality control. The intent of this paragraph, however, is to ensure proper consideration of any potential escape of fissile material from the package where loss of criticality control must be assumed.

682.3. The assessment conditions considered should also include those arising from events less severe than the test conditions. For example, it is possible for a package to be subcritical following a 9 m drop but to be critical under conditions consistent with a less severe impact.

682.4. See paras 681.1–681.3.

REFERENCES TO SECTION VI

- [1] GORDON, G., GREDINGH, R., Leach Test of Six 192-Iridium Pellets Based on the IAEA Special Form Test Procedures, AECB Rep. Info-0106, Atomic Energy Control Board, Ottawa (1981).
- [2] INTERNATIONAL ORGANIZATION FOR STANDARDIZATION, Radiation Protection — Sealed Radioactive Sources — Leakage Test Methods, ISO 9978, ISO, Geneva (1992).
- [3] ASTON, D., BODIMEADE, A.H., HALL, E.G., TAYLOR, C.B.G., The Specification and Testing of Radioactive Sources Designated as ‘Special Form’ Under the IAEA Transport Regulations, CEC Study Contract XVII/322/80.6, Rep. EUR 8053, CEC, Luxembourg (1982).
- [4] COOKE, B., “Trunnions for Spent Fuel Element Shipping Casks”, Packaging and Transportation of Radioactive Materials, PATRAM 89 (Proc. Symp. Washington, DC, 1989), Oak Ridge National Laboratory, Oak Ridge, TN (1989).
- [5] AMERICAN NATIONAL STANDARDS INSTITUTE, American National Standard for Special Lifting Devices for Shipping Containers Weighing 10 000 Pounds (4,500 kg) or More for Nuclear Materials, ANSI N14.6-1978, ANSI, New York (1978).
- [6] KERNTECHNISCHER AUSSCHUSS, Lastanschlagpunkte in Kernkraftwerken, KTA 3905, KTA Geschäftsstelle, Bundesamt für Strahlenschutz, Salzgitter (1999).
- [7] INTERNATIONAL CIVIL AVIATION ORGANIZATION, Technical Instructions for the Safe Transport of Dangerous Goods by Air, 1998–1999 edition, ICAO, Montreal (1996).
- [8] UNITED NATIONS, Recommendations on the Transport of Dangerous Goods, Ninth Revised Edition, ST/SG/AC.10/1/Rev.9, UN, New York and Geneva (1995).

- [9] INTERNATIONAL ORGANIZATION FOR STANDARDIZATION, Series 3 Tank Containers for Liquids and Gases — Specification and Testing, ISO 1496/3-1990, Part 3, ISO, Geneva (1990).
- [10] UNITED NATIONS ECONOMIC COMMISSION FOR EUROPE, INLAND TRANSPORT COMMITTEE, European Agreement Concerning the International Carriage of Dangerous Goods by Road (ADR), 1997 edition, marginals 10315, 71315 and Appendix B4, UNECE, Geneva (1997).
- [11] UNITED NATIONS ECONOMIC COMMISSION FOR EUROPE, INLAND TRANSPORT COMMITTEE, Regulations concerning the International Carriage of Dangerous Goods by Rail (RID), UNECE, Geneva (1995).
- [12] INTERNATIONAL ORGANIZATION FOR STANDARDIZATION, Series 1 Freight Containers — Specifications and Testing — Part 1: General Cargo Containers, ISO 1496:1-1990(E), ISO, Geneva (1990).
- [13] INTERNATIONAL MARITIME ORGANIZATION, International Convention for Safe Containers, IMO, London (1984).
- [14] INTERNATIONAL ORGANIZATION FOR STANDARDIZATION, Packaging of Uranium Hexafluoride (UF₆) for Transport, ISO 7195:1993(E), ISO, Geneva (1993).
- [15] MALLET, A.J., ORGDP Container Test And Development Programme: Fire Tests of UF₆-filled Cylinders, K-D-1984, Union Carbide Corp., Oak Ridge, TN (1966).
- [16] RINGOT, C., HAMARD, J., “The toxic and radiological risk equivalence approach in UF₆ transport”, UF₆ — Safe Handling, Processing and Transporting (Proc. Conf. Oak Ridge, 1988), Oak Ridge Gaseous Diffusion Plant, Oak Ridge, TN (1988) 29–36.
- [17] BIAGGIO, A., LOPEZ-VIETRI, J., “UF₆ in transport accidents”, Packaging and Transportation of Radioactive Materials, PATRAM 86 (Proc. Symp. Davos, 1986), IAEA, Vienna (1986).
- [18] SAROUL, J., et al., “UF₆ transport container under fire conditions, experimental results”, Uranium Hexafluoride: Processing, Handling, Packaging, Transporting (Proc. 3rd Int. Conf. Paducah, KY, 1995), Institute of Nuclear Materials Management, Northbrook, IL (1995).
- [19] PINTON, E., DURET, B., RANCILLAC, F., “Interpretation of TEN2 experiments”, *ibid.*
- [20] WILLIAMS, W.R., ANDERSON, J.C., “Estimation of time to rupture in a fire using 6FIRE, a lumped parameter UF₆ cylinder transient heat transfer/stress analysis model”, *ibid.*
- [21] WATARU, M., et al., “Safety analysis on the natural UF₆ transport container”, *ibid.*
- [22] LYKINS, M.L., “Types of corrosion found on 10- and 14-ton mild steel depleted uranium UF₆ storage cylinders”, *ibid.*
- [23] BLUE, S.C., “Corrosion control of UF₆ cylinders”, *ibid.*
- [24] CHEVALIER, G., et al., “L’arrimage de colis de matières radioactives en conditions accidentelles”, Packaging and Transportation of Radioactive Materials, PATRAM 86 (Proc. Symp. Davos, 1986), IAEA, Vienna (1986).
- [25] UNITED STATES ENRICHMENT CORPORATION, Reference USEC-651, USEC, Washington, DC (1998).

- [26] BRITISH STANDARDS INSTITUTE, Guide to the Design, Testing and Use of Packaging for the Safe Transport of Radioactive Materials, BS 3895:1976, GR 9, BSI, London (1976).
- [27] AMERICAN NATIONAL STANDARDS INSTITUTE, American National Standard for Leakage Tests on Packages for Shipment of Radioactive Material, ANSI N14.5-1977, ANSI, New York (1977).
- [28] INTERNATIONAL ORGANIZATION FOR STANDARDIZATION, Safe Transport of Radioactive Material — Leakage Testing of Packages, ISO 12807:1996(E), first edition 1996-09-15, ISO, Geneva (1996).
- [29] MACDONALD, H.F., “Individual and collective doses arising in the transport of irradiated nuclear fuels”, Packaging and Transportation of Radioactive Materials, PATRAM 80 (Proc. Symp. Berlin, 1980), Bundesanstalt für Materialprüfung, Berlin (1980).
- [30] GOLDFINCH, E.P., MACDONALD, H.F., Dosimetric aspects of permitted activity leakage rates for Type B packages for the transport of radioactive materials, Radiat. Prot. Dosim. **2** (1982) 75.
- [31] MACDONALD, H.F., Radiological Limits in the Transport of Irradiated Nuclear Fuels, Rep. TPRD/B/0388/N84, Central Electricity Generating Board, Berkeley, UK (1984).
- [32] MACDONALD, H.F., GOLDFINCH, E.P., The Q System for the Calculation of A_1 and A_2 Values within the IAEA Regulations for the Safe Transport of Radioactive Materials, Rep. TPRD/B/0340/R83, Central Electricity Generating Board, Berkeley, UK (1983).
- [33] UNITED KINGDOM ATOMIC ENERGY AUTHORITY, Shielding Integrity Testing of Radioactive Material Transport Packaging, Gamma Shielding, Rep. AECF 1056, Part 1, UKAEA, Harwell (1977).
- [34] UNITED KINGDOM ATOMIC ENERGY AUTHORITY, Testing the Integrity of Packaging Radiation Shielding by Scanning with Radiation Source and Detector, Rep. AESS 6067, UKAEA, Risley (1977).
- [35] INTERNATIONAL ORGANIZATION FOR STANDARDIZATION, Radioactive Materials — Packaging — Test for Contents Leakage and Radiation Leakage, ISO 2855-1976(E), ISO, Geneva (1976).
- [36] AMERICAN NATIONAL STANDARDS INSTITUTE, American National Standard for Program for Testing Biological Shielding in Nuclear Reactor Plants, ANSI N18.9-1972, ANSI, New York (1972).
- [37] JANARDHANAN, S., et al., “Testing of massive lead containers by gamma densitometry”, Industrial Isotope Radiography (Proc. Nat. Symp.), Bharat Heavy Electrical Ltd., Tiruchirapalli, India (1976).
- [38] KRISHNAMURTHY, K., AGGARMAL, K.S., “Complementary role of radiometric techniques in radiographic practice”, *ibid.*
- [39] NAGAKURA, T., MAKI, Y., TANAKA, N., “Safety evaluation on transport of fuel at sea and test program on full scale cask in Japan”, Packaging and Transportation of Radioactive Materials, PATRAM 78 (Proc. Symp. New Orleans, 1978), Sandia Laboratories, Albuquerque, NM (1978).
- [40] HEABERLIN, S.W., et al., Consequences of Postulated Losses of LWR Spent Fuel and Plutonium Shipping Packages at Sea, Rep. BNWL-2093, Battelle Pacific Northwest Laboratory, Richland, WA (1977).

- [41] HIGSON, J., VALLEPIN, C., KOWALEVSKY, H., "A review of information on flow equations for the assessment of leaks in radioactive transport containers", *Packaging and Transportation of Radioactive Materials*, PATRAM 89 (Proc. Symp. Washington, DC, 1989), Oak Ridge National Laboratory, Oak Ridge, TN (1989).
- [42] BURNAY, S.G., NELSON, K., "Leakage of transport container seals during slow thermal cycling to -40°C ", *Int. J. Radioact. Mater. Transp.* **2** (1991).
- [43] JAPAN ATOMIC ENERGY RESEARCH INSTITUTE, *Nuclear Criticality Safety Handbook*, Nihon Shibou, Science and Technology Agency (1988) (in Japanese). [English translation: JAERI-Review 95-013, JAERI, Tokyo (1995).]
- [44] COMMISSARIAT A L'ENERGIE ATOMIQUE, *Guide de Criticité*, Rep. CEA-R-3114, CEA, Paris (1967).
- [45] WOODCOCK, E.R., PAXTON, H.C., "The criticality aspects of transportation of fissile materials", *Progress in Nuclear Energy, Series IV, Vol. 4*, Pergamon Press, Oxford (1961) 401–430.
- [46] DANIELS, J.T., *A Guide to the Requirements Relating to Fissile Materials* (GIBSON, R., Ed.), Pergamon Press, Oxford (1961).
- [47] PAXTON, H.C., PRUVOST, N.L., *Critical Dimensions of Systems Containing U-235, Pu-239 and U-233*, Rep. LA-10860-MS, Los Alamos National Laboratory, Los Alamos, NM (1987).
- [48] AMERICAN NATIONAL STANDARD for Nuclear Criticality Control and Safety of Plutonium-Uranium Fuel Mixtures Outside Reactors, Rep. ANSI/ANS-8.12-1987, American Nuclear Society, LaGrange Park, IL (1987).
- [49] *The Nuclear Criticality Safety Guide*, Rep. LA-12808, Los Alamos National Laboratory, Los Alamos, NM (1996).
- [50] BARTON, N.J., WILSON, C.K., "Review of fissile exception criteria in IAEA regulations", *Nuclear Criticality Safety (ICNC'95, Proc. 5th Int. Conf. Albuquerque, 1995)*, Vol. 2, Univ. of New Mexico, Albuquerque, NM (1995) 915–972.
- [51] CLARK, H.K., "Sub-critical limits for plutonium systems", *Nucl. Sci. Eng.* **79** (1981) 65–84.
- [52] CLARK, H.K., "Sub-critical limits for uranium-235 systems", *Nucl. Sci. Eng.* **81** (1981) 351–378.
- [53] CLARK, H.K., "Sub-critical limits for uranium-233 systems", *Nucl. Sci. Eng.* **81** (1981) 379–395.
- [54] TAKANO, M., OKUNO, H., *OECD/NEA Burnup Credit Criticality Benchmark, Result of Phase IIA*, Rep. NEA/NSC/DOC(96)01, Japan Atomic Energy Research Institute, Tokyo (1996).
- [55] DEHART, M.D., PARKS, C.V., "Issues related to criticality safety analysis for burnup credit applications", *Nuclear Criticality Safety (ICNC'95, Proc. 5th Int. Conf. Albuquerque, 1995)*, Univ. of New Mexico, Albuquerque, NM (1995) 26–36.
- [56] BOWDEN, R.L., THORNE, P.R., STRAFFORD, P.I., "The methodology adopted by British Nuclear Fuels plc in claiming credit for reactor fuel burnup in criticality safety assessments", *ibid.*, pp. 1b.3–10.

Section VII

TEST PROCEDURES

DEMONSTRATION OF COMPLIANCE

701.1. The Regulations contain performance standards, as opposed to specific design requirements. While this means greater flexibility for the designer it presents more difficulties in obtaining approval. The intent is to allow the applicant to use accepted engineering practice to evaluate a package or radioactive material. This could include the testing of full scale packages, scale models, mock-ups of specific parts of a package, calculations and reasoned arguments, or a combination of these methods. Regardless of the methods used, documentation should be sufficiently complete and proper to satisfy the competent authority that all safety aspects and modes of failure have been considered. Any assumption should be clearly stated and fully justified.

701.2. Testing packages containing radioactive material presents a special challenge because of the radioactive hazard. While it may not be advisable to perform the tests required using radioactive material, it is necessary to convince the competent authority that the regulatory requirements have been met. When determining whether radioactive material or the intended radioactive contents are to be used in the tests, a radiological safety assessment should be made.

701.3. Many other factors should be considered in demonstrating compliance. These include but are not limited to the complexity of the package design, special phenomena that require investigation, the availability of facilities, and the ability to accurately measure and/or scale responses.

701.4. Where the Regulations require compliance with a specific leakage limit, the designer should incorporate some means in the design to readily demonstrate the required degree of leaktightness. One method is to include some type of sampling chamber or test port that can be readily checked before shipment.

701.5. Test models should accurately represent the intended design, with manufacturing methods and quality assurance and quality control similar to that intended for the finished product. Increased emphasis should be placed on the prototype in order to ensure that a test specimen is a true representation of the product. If simulated radioactive contents are being used, these contents should truly represent the actual contents in mass, density, chemical composition, volume and any other

characteristics that are significant. The contents should simulate any impact loads on the inside surface of the package and any closure lids. Any deficiencies or differences in the model should be documented before the testing, and some evaluation should be done to determine how this may affect the outcome of the tests, either positively or negatively.

701.6. The number of specimens used in testing will be related to the design features to be tested and to the desired reliability of the assessments. Repetition of tests with different specimens may be used to account for variations due to the range of properties in the material specifications or tolerances in the design.

701.7. The results of the tests may necessitate an increase in the number of specimens in order to meet the requirements of the test procedures in respect of maximum damage. It may be possible to use computer code simulations to reduce the number of tests required.

701.8. Care has to be exercised when planning the instrumentation and analysis of either a scale model test or a full scale test. It should be ensured that adequate and correctly calibrated instrumentation and test devices are provided so that the test results may be documented and evaluated in order to verify the test results. At the same time, it is necessary to ensure that the instrumentation, test devices and electrical connections do not interfere with the model in a way that would invalidate the test results.

701.9. When acceleration sensors are used to evaluate the impact behaviour of the package, the cut-off frequency should be considered. The cut-off frequency should be selected to suit the structure (shape and dimension) of the package. Experience suggests that, for a package with a mass of 100 metric tonnes with impact limiter, the cut-off frequency should be 100 to 200 Hz, and that, for smaller packages with a mass of m metric tonnes, this cut-off frequency should be multiplied by a factor $(100/m)^{1/3}$. When the package includes components necessary to guarantee the safety under impact, and these components have a fundamental resonance or first mode frequencies exceeding the above mentioned cut-off value, the cut-off frequency may need to be adjusted so that the eliminated part of the signal has no significant influence on the assessment of the mechanical behaviour of these components. In these cases, a modal analysis may be necessary. Examples of such components include shells under evaluation for brittle fracture and internal arrangement structures needed for guaranteeing subcriticality. When such an issue is dealt with in an analytical evaluation, the calculation method and modelling should allow a pertinent assessment of these dynamic effects. This may require adjustment of the time

steps and mesh size to low values consistent with the above mentioned frequencies used in the calculation.

701.10. In many cases, it may be simpler and less expensive to test a full scale model rather than use a scale model or demonstrate compliance by calculation and reasoned argument. One disadvantage in relying completely on testing is that any future changes to either the contents or the package design may be much harder or impossible to justify. On a practical basis, unless the packages are very inexpensive to construct and several are tested, it usually requires additional work to justify the test attitude.

701.11. In considering reference to previously satisfactory demonstrations of a similar nature, all the similarities and the differences between two packages should be considered. The areas of difference may require modification of the results of the demonstration. The ways and the extent to which the differences and similarities will qualify the results from the previous demonstration depend upon their effects. In an extreme case, a packaging may be geometrically identical with that used in an approved package but, because of material changes in the new packaging, the reference to the previous demonstration would not be relevant and hence should not be used.

701.12. Another method of demonstrating compliance is by calculation, or reasoned argument, when the calculation procedures and parameters are generally agreed upon to be reliable or conservative. Regardless of the qualification method chosen, there will probably be a need to carry out some calculations and reasoned argument. Material properties in specifications are usually supplied to yield a probability of not being under strength of between 95 and 98%. When tests are used for determining material property data, scatter in the data should be taken into account. It is usual to factor results where the number of tests is limited to give a limit of the mean plus twice the standard deviation on a normal (Gaussian) distribution (approximately 95% probability). It is also necessary to consider scatter due to material and manufacturing tolerances unless all calculations use the worst combination of possible dimensions. When computer codes are used it should be made abundantly clear that the formulations used are applicable to finite deformation (i.e. not only large displacement but also large strain). In most cases the requirements, especially those involving accidental impact, will necessitate a finite strain formulation due to the potential severe damage inflicted. Ignoring such details could lead to significant error. Any reasoned arguments should be based on engineering experience. Where theory is used, due account should be taken of design details which could modify the result of general theory, e.g. discontinuities, asymmetries, irregular geometry, inhomogeneities or variable material properties. The presentation of reasoned argument based on subjective material should be avoided.

701.13. Many calculations could require the use of commercially available computer codes. The reliability and the appropriate validation of the computer code selected should be considered. First, is the code applicable for the intended calculation? For example, for mechanical assessments, can it accept impact calculations? Is it suitable for calculating plastic as well as elastic deformations? Second, does the computer code adequately represent the packaging under review for the purpose of compliance? To meet these two criteria it may be necessary for the user to run 'benchmark' problems, which use the code to model and calculate the parameters of a problem in which the results are known. Options settings may have a strong influence on the validity of the benchmark studies to the problem being solved. In mechanical codes, options and modelling considerations include package material properties under dynamic conditions, elastic and plastic deformations, detailing connections between components such as screws and welds, and allowing friction, hydrodynamic, sliding and damping effects. User experience in the proper selection of code options, material properties and mesh selection can affect results when using a particular code. Benchmark studies should also consider sensitivity of the results to parameter variation. Confidence can be increased by systematic benchmarking, proceeding from the simple to the complex. For other uses, checks that the input and output balance in load or energy may be required. When the code used is not widely employed and known, proof of the theoretical correctness should also be given.

701.14. Justification of the design may be done by the performance of tests with models of appropriate scale incorporating features significant with respect to the item under investigation when engineering experience has shown results of such tests to be suitable for design purposes. When a scale model is used, the need for adjusting certain test parameters, such as penetrator diameter or compressive load, should be taken into account. On the other hand, certain test parameters cannot be adjusted. For example, both time and gravitational acceleration are real, and therefore it will be necessary to adjust the results by use of scaling factors. Scale modelling should be supported by calculation or by computer simulation using benchmarked computer software to ensure that an adequate margin of safety exists.

701.15. When scale models are used to determine damage, due consideration should be given to the mechanisms affecting energy absorption since friction, rupture, crushing, elasticity, plasticity and instability may have different scale factors as a result of different parameters in the test being effected. Also, since the demonstration of compliance requires the combination of three tests (such as penetration, drop and thermal tests for Type B(U) and Type B(M) packages), conflicting requirements for the test parameters may require a compromise, which in turn would give results that require scale factoring. In summary, the effect of scaling for all areas of difference should be considered.

701.16. Experience has shown that the testing of scale models may be very useful for demonstrating compliance with certain specific requirements of the Regulations, particularly the mechanical tests. Attempts to perform thermal tests using scale models are problematic (see paras 728.23 and 728.24). In mechanical tests, the conditions of similitude are relatively simple to create, provided the same materials and suitable methods of construction are used for the model as for the full sized package. Thus, in an economical manner, it is possible to study the relation of package orientation and the resulting damage, and the overall deformation of the package, and to obtain information concerning the deceleration of package parts. In addition, many design features can be optimized by model testing.

701.17. The details which should be included in the model are a matter of judgement and depend on the type of test for which the model is intended. For example, in the determination of the structural response from an end impact, the omission of lateral cooling fins from the scale model may result in more severe damage. This type of consideration may greatly simplify construction of the model without detracting from its validity. Only pertinent structural features which may influence the outcome of the test need be included. It is essential, however, that the materials of construction for the scale model and the full sized package are the same and that suitable construction and manufacturing techniques are used. In this sense, the construction and manufacturing techniques which will replicate the mechanical behaviour and structural response of the full sized package should be used, giving consideration to such processes as machining, welding, heat treatment and bonding methods. The stress-strain characteristics of the construction materials should not be strain rate dependent to a point which would invalidate the model results. This point needs to be made in view of the fact that strain rates in the model may be higher than in the full sized package.

701.18. In some cases it may not be practical to scale all components of the package precisely. For example, consider the thickness of an impact limiter compared to the overall length of the package. In the model, the ratio of the thickness to the overall length may differ from that of the actual package. Other examples include sheet metal gauge, gasket or bolt size that may not be standard size or may not be readily available. When any appreciable geometrical discrepancy exists between the actual package and the model to be tested, the behaviour of both when subjected to the 9 m drop should be compared by computer code analyses to determine whether the effect of geometrical discrepancy is a significant consideration. The computer code employed should be a code which has been verified through appropriate benchmark tests. If the effects of the discrepancies are not significant, the model could be considered suitable for a scale model drop test. This applies to a scale ratio of 1:4 or greater.

701.19. The scale factor chosen for the model is another area where a judgement needs to be made since the choice of scale factor depends on the accuracy necessary to ensure an acceptable model representation. The greater the deviation from full scale, the greater the error that is introduced. Consequently, the reduction of scale might be greater for a study of package deformation as a whole than for testing certain parts of the package, and in some cases the scale factor chosen may be determined by the particular type of test being undertaken. In some tests, such as the penetration tests specified in the Regulations, the bar should be scaled in order to produce accurate results. In other cases where the packaging may be protected by a significant thickness of deformable structure, the drop height may need to be scaled.

701.20. In general, the scale ratio M (the ratio of the model dimension to the prototype dimension) should be not less than 1:4. For a model with a scale ratio of 1:4 or larger, the effect of strain rate dependence on the material's mechanical properties will be negligibly small. The effect of strain rate dependence for typical materials (e.g. stainless steel) should be checked.

701.21. Scaling of drop tests is possible, taking into account the limitations given below, as a result of the following model laws, which are valid when the original drop height is maintained:

$$\begin{array}{ll} \text{Accelerations:} & a_{\text{model}} = (a_{\text{original}})/M \\ \text{Forces:} & F_{\text{model}} = (F_{\text{original}})M^2 \\ \text{Stresses:} & \sigma_{\text{model}} = \sigma_{\text{original}} \\ \text{Strains:} & \epsilon_{\text{model}} = \epsilon_{\text{original}} \end{array}$$

701.22. For lightweight models, the model attitude or velocity during drop testing could be affected by such things as the swing of an 'umbilical cord' carrying wires for acceleration sensors or strain gauges, or by wind effects. Experience suggests that, for packages with mass up to 1000 kg, full scale models should be used for the test, or special guides should be used with the scale model.

701.23. When an application for approval of a package design is based to any extent on scale model testing, the application should include a demonstration of the validity of the scaling methods used. In particular, such a demonstration should include:

- definition of the scale factor;
- demonstration that the model constructed reproduces sufficiently accurately the details of the package or packaging parts to be tested;
- a list of parts or features not reproduced in the model;

- justification for deletion of parts or features in the model; and
- justification of the similitude criteria used.

701.24. In the evaluation of the results of a scale model test, not only the damage sustained by the packaging, but, in some cases, the damage to the package contents should be considered. In particular, damage to the package contents should be considered when it involves a change in:

- release rate potential;
- parameters affecting criticality;
- shielding effectiveness;
- thermal behaviour.

701.25. It might be difficult to extrapolate the results of scale model testing involving seals and sealing surfaces to the responses expected in a full sized package. Although it is possible to acquire valuable information on the deformation and displacement of sealing surfaces with scale models, extrapolation of seal performance and leakage should be approached with caution (see para. 716.7). When scale models are used to test seals, the possible effect of such factors as surface roughness, seal behaviour as a function of material thickness and type, and the problems associated with predicting leakage rates on the basis of scale model results should be considered.

702.1. Any post-test assessment method used to assure compliance should incorporate the following techniques as appropriate to the type of package under examination:

- visual examination;
- assessment of distortion;
- seal gap measurements of all closures;
- seal leakage testing;
- destructive and non-destructive testing and measurement; and
- microscopic examination of damaged material.

702.2. In the evaluation of damage to a package after a drop test, all damage from secondary impacts should be considered as well. Secondary impact includes all additional impacts between the package and target, following initial impact. For evaluations based on numerical methods, it is also necessary to consider secondary impacts. Accordingly, the attitude of the package which produces maximum damage has to be determined with secondary as well as initial impacts taken into account. Experience suggests that the effect of secondary impact is often more severe for slender and rigid packages, including:

- a package with an aspect ratio (length to diameter) larger than 5, but sometimes even as low as 2;
- a large package when significant rebound is expected to occur following the 9 m drop; and
- a package in which the contents are rigid and slender and particularly vulnerable to lateral impacts.

TESTS FOR SPECIAL FORM RADIOACTIVE MATERIAL

General

704.1. The four test methods specified in the Regulations, namely the impact, percussion, bending and heat tests, are intended to simulate mechanical and thermal effects to which a special form radioactive material might be exposed if released from its packaging.

704.2. These test requirements are provided to ensure that special form radioactive materials which become immersed in liquids as a result of an accident will not disperse more than the limits given in para. 603.

704.3. The tests of a capsule design may be performed with simulated radioactive material. The term 'simulated' means a facsimile of a radioactive sealed source, the capsule of which has the same construction and is made with exactly the same materials as those of the sealed source that it represents, but contains, in place of the radioactive material, a substance with mechanical, physical and chemical properties as close as possible to those of the radioactive material and containing radioactive material of tracer quantities only. The tracer should be in a form soluble in a solvent which does not attack the capsule. One procedure described in ISO 2919 [1] utilizes either 2 MBq of Sr-90 and Y-90 as soluble salt, or 1 MBq of Co-60 as soluble salt. When possible, shorter lived nuclides should be used. However, if leaching assessment techniques are used, care needs to be taken when interpreting the results. The effects of scaling will have to be introduced, the importance of which will depend upon the maximum activity to be contained within the capsule and also the physical form of the intended capsule contents, particularly the solubility of the intended capsule contents as compared with the tracer radionuclide. These problems can be avoided if volumetric leakage tests are used (see paras 603.3 and 603.4). Typically, tests for special form radioactive material are performed on full scale sealed sources or indispensible solid material because these are not expensive and the results of the tests are easy to interpret.

Test methods

705.1. Since this test is intended to be analogous to the Type B(U) package 9 m drop test (see para. 603.1), the specimen should be dropped so as to suffer maximum damage.

706.1. Special attention should be paid to the percussion test conditions in order to get maximum damage.

709.1. It is recognized that the tests indicated in paras 705, 706 and 708 are not unique and that other internationally accepted test standards may be equally acceptable. Two tests prescribed by the International Organization for Standardization have been identified as adequate alternatives.

709.2. The alternative test proposed in para. 709(a) is the ISO 2919 [1] Impact Class 4 test, which consists of the following: a hammer, with a mass of 2 kg, the flat striking surface having a diameter of 25 mm, with its edge rounded to a radius of 3 mm, is allowed to drop on the specimen from a height of 1 m; the specimen is placed on a steel anvil which has a mass of at least 20 kg. The anvil is required to be rigidly mounted and has a flat surface large enough to take the whole of the specimen. This test may be employed in place of both the impact test (para. 705) and the percussion test (para. 706).

709.3. The alternative test proposed in para. 709(b) is the ISO 2919 [1] Temperature Class 6 test which consists of subjecting the specimen to a minimum temperature of -40°C for 20 min and heating over a period not exceeding 70 min from ambient to 800°C ; the specimen is then held at 800°C for 1 h, followed by thermal shock treatment in water at 20°C .

Leaching and volumetric leakage assessment methods

711.1. For specimens which comprise or simulate radioactive material enclosed in a sealed capsule, either a leaching assessment as required in para. 711(a) or one of the volumetric leakage assessment methods as specified in para. 711(b) should be applied. The leaching assessment is similar to the method applied to indispersible solid material (see para. 710), except that the specimen is not initially immersed in water for seven days. The other steps, however, remain the same.

711.2. The alternative volumetric leakage assessment as specified in para. 711(a) comprises any of the tests prescribed in ISO 9978 [2] which are acceptable to the competent authority. The tests generally allow for a reduction in the test period and, in addition, some of these tests are for non-radioactive substances. The volumetric leakage assessment option provides for a reduction in the time involved in the entire sequence of testing and may include a reduction of the period of time for using a shielded cell during the test. Therefore, the volumetric leakage assessment option could result in considerable cost reduction.

TESTS FOR LOW DISPERSIBLE RADIOACTIVE MATERIAL

712.1. To receive relief from the Type C package requirements, low dispersible radioactive material (LDM) must meet the same performance criteria for impact and fire resistance as a Type C package without producing significant quantities of dispersible material.

712.2. To qualify as LDM, certain material properties have to be demonstrated by appropriate direct physical tests, by analytical methods or a proper combination of these. It has to be shown that, if the contents of a Type B(U) package or Type B(M) package were to be subjected to the required tests, they would meet the performance criteria laid down in para. 605. Three tests are required: the 90 m/s impact test onto an unyielding target, the enhanced thermal test and the leaching test. The impact and thermal tests are non-sequential. For the leaching test the material has to be in a form representative of the material properties following either the mechanical or the thermal test. The tests to demonstrate the required LDM properties do not have to be performed with the entire package contents if the results obtained with a representative fraction of the package contents can be scaled up to the full package contents in a reliable way. This is, for example, the case if the package contents consist of several identical items, and it can be shown that multiplying the release established for one such item by the total number of such items in a package gives an upper estimate for the whole package contents. For large items it is also possible to perform tests with an essential part of them, or with a scaled down model, as long as it is established how the test results obtained in this way can be extrapolated to the release behaviour of the entire package contents.

712.3. For the 90 m/s impact test it has to be demonstrated that the impact of the entire package contents, unprotected by the packaging, onto an unyielding target with a speed of at least 90 m/s would lead to a release of airborne radioactive material in gaseous or particulate form up to 100 μm aerodynamic equivalent diameter (AED) of less than 100 A_2 . The aerodynamic equivalent diameter of an aerosol particle is

defined as the diameter of a sphere of density 1 g/cm^3 which has the same sedimentation behaviour in air. The AED of aerosol particles can be determined by a variety of aerosol measuring instruments and techniques such as impactors, optical particle counters and centrifugal separators (cyclones). Various experimental test procedures may be used. One possible approach is to impact a horizontally flying test specimen onto a vertical wall that has the required unyielding target attributes. All particulate matter with AED below $100 \mu\text{m}$ that becomes airborne can be transported upward by an upward directed airstream of appropriate speed and then analysed according to particle size by established aerosol measuring techniques. An airstream with an upward speed of about 30 cm/s would serve as a separator, in that particles with $\text{AED} < 100 \mu\text{m}$ would remain airborne, whereas larger particles would be removed since their settling velocity exceeds 30 cm/s .

712.4. See paras 605.5, 605.7–605.9 and 704.3 for additional information.

TESTS FOR PACKAGES

Preparation of a specimen for testing

713.1. Unless the actual condition of the specimen had been recorded in advance of the test, it would be difficult to decide subsequently whether any defect was caused by the test.

714.1. Since, in certain cases, components forming a containment system may be assembled in different ways, it is essential for test purposes that the specimen and the method of assembly be clearly defined.

Testing the integrity of the containment system and shielding, and assessing criticality safety

716.1. In order to establish the performance of specimens which have been subjected to the tests specified in paras 719–733 it may be necessary to undertake an investigation programme involving both inspection and further subsidiary testing. Generally, the first step will be a visual examination of the specimen and recording by photography. In addition, other inspections may be necessary. If the tests were performed with specimens containing radioactive trace material, wipe tests may give a measurement of the leakage. Leaktightness may be detected by following the procedures outlined in paras 646.3–646.5 (Type IP, Type A, Type B). Likewise, the shielding integrity may be evaluated by the use of trace radiation materials placed inside the packaging. After examination of the outer integrity, the containment

system should be disassembled to check the interior situation: integrity of capsules, glass, flasks, etc.; stability of geometrical compartments, particularly in the case where the intended contents are fissile material; distribution of absorbent material; stability of shielding; and function of mechanical parts. The investigatory programme should be aimed at examining three specific areas:

- integrity of the containment system;
- integrity of shielding;
- assurance, where applicable, that no rearrangement of the fissile contents or neutron poison or degree of moderation has adversely influenced the assumptions and predictions of the criticality assessment.

716.2. The integrity of the containment system can be evaluated in many ways. For example, the radioactive release from the containment system can be calculated on the basis of the volumetric (e.g. gaseous) release.

716.3. In the case of test specimens representative of full sized containment systems, direct leakage measurements can be made on the test specimen.

716.4. The two following areas need attention:

- the performance of the normal closure system; and
- the leakage levels which may have occurred elsewhere in the containment system.

716.5. Containment, in accordance with the Regulations, involves so many variables that a single standard test procedure is not feasible.

716.6. In the American National Standard N14.5-1977 [3], acceptable types of test, listed in order of increasing sensitivity under usual conditions, include but are not limited to:

- gas pressure drop
- water immersion bubble or soap bubble
- ethylene glycol
- gas pressure rise
- vacuum air bubble
- halogen detector
- helium mass spectrometer.

716.7. This standard:

- relates the regulatory requirements for radioactive material containment to practical detectable mass flow leakage rates;
- defines the term ‘leaktight’ in terms of a volumetric flow rate;
- makes some simplifying, conservative assumptions so that many of the variables may be consolidated;
- describes a release test procedure; and
- describes specific volumetric leakage tests.

716.8. ISO 12807 [4] specifies gas leakage test criteria and tests methods for demonstrating that Type B(U) and B(M) packages comply with the integrity containment requirements of the Regulations for design, fabrication, pre-shipment and periodic verifications. Preferred leakage test methods described by ISO 12807 include but are not limited to:

- (a) Quantitative methods:
 - gas pressure drop
 - gas pressure rise
 - gas filled envelope gas detector
 - evacuated envelope gas detector
 - evacuated envelope with back-pressurization
- (b) Qualitative methods:
 - gas bubble techniques
 - soap bubble technique
 - tracer gas sniffer technique
 - tracer gas spray method.

716.9. This standard is mainly based on the following assumptions:

- radioactive material could be released from the package in liquid, gas, solid, liquid with solids in suspension or particulate solid in a gas (aerosol), or any combination of such forms;
- radioactive release or leakage can occur by one or more of the following ways: viscous flow, molecular flow, permeation or blockage;
- the radioactive contents release rate is measured indirectly by an equivalent gas leakage test in which it is measured by gas flow rates (non-radioactive gas); and
- rates can be related mathematically to the diameter of a single straight capillary which in most cases is considered to conservatively represent a leak or leaks.

716.10. The main steps considered in the standard for determining leakage in both normal and accident conditions of transport are the following:

- determination of permissible radioactive release rates,
- determination of standardized leakage rates,
- determination of permissible test leakage rates for each verification stage,
- selection of appropriate test methods, and
- performance of tests and records of results.

716.11. If specimens less than full size have been used for test purposes, direct measurement of leakage past seals may not be advisable as not all parameters associated with leakage past seals are readily scaled. In this instance, because loss of sealing is often associated with loss of seal compression resulting from, for example, permanent extension of the closure cover bolts, it is recommended that a detailed metrology survey be made to establish the extent to which bolt extension and distortion of the sealing faces has occurred on the test specimen following the mechanical tests. The data based on a detailed metrology survey may be scaled and the equivalent distortion and bolt extension at full size determined. From tests with full sized seals using the scaled metrology data the performance of the full sized package may be determined.

716.12. For evaluating shielding integrity, ISO 2855 [5] draws attention to the fact that, if a radioactive source is to be used to establish the post-accident test condition, any damage or modification to the post-test package configuration caused by the insertion of the source might invalidate the results obtained.

716.13. If a full size specimen has been used for testing, one method of proving the integrity of the shielding is that, with a suitable source inside the specimen, the entire surface of the specimen is examined with an X ray film or an appropriate instrument to determine whether there has been a loss of shielding. If there is evidence of loss of shielding at any point on the surface of the specimen, the radiation level should be determined by actual measurement and calculation to ensure compliance with paras 646, 651, 656 and 669. For additional information, refer to paras 646.1–646.5 and 656.13–656.18.

716.14. Alternatively, a careful dimensional survey could be made of those parameters that contribute to shielding performance to ascertain that they have not been adversely affected, e.g. by slumping or loss of lead from shields, giving rise to either a general increase in radiation or increased localized radiation levels.

716.15. The applicable tests may demonstrate that the assumptions used in the criticality safety assessment are not valid. A change in the geometry or the physical or chemical form of the packaging components or contents could affect the neutron interaction within or between packages, and any change should be consistent with the

assumptions made in the criticality safety assessment of paras 671–682. If the conditions after the tests are not consistent with the assumptions of the criticality safety assessment, the assessment may need to be modified.

716.16. Although the testing of the package at full or smaller scale can be carried out with simulated contents from which some data on the behaviour of any basket or skip used for positioning the contents can be obtained, the final geometry will in practice depend upon the interaction of the actual material (whose mechanical properties may be different from the simulated contents) with both the basket or skip and the other components of the packaging.

Target for drop tests

717.1. The target for drop tests is specified as an essentially unyielding surface. This unyielding surface is intended to cause damage to the package which would be equivalent to, or greater than, that anticipated for impacts onto actual surfaces or structures which might occur during transport. The specified target also provides a method for assuring that analyses and tests can be compared and accurately repeated if necessary. The unyielding target, even though described in general terms, can be repeatedly constructed to provide a relatively large mass and stiffness with respect to the package being tested. So-called real targets, such as soil, soft rock and some concrete structures, are less stiff and could cause less damage to a package for a given impact velocity [6]. In addition, it is more difficult to construct yielding surfaces that give reproducible test results, and the shape of the object being dropped can affect the yielding character of the surface. Thus, if yielding targets were used, the uncertainty of the test results would increase, and the comparison between calculations and tests would be much more difficult.

717.2. One example of an unyielding target to meet the regulatory requirements is a 4 cm thick steel plate floated on to a concrete block mounted on firm soil or bedrock. The combined mass of the steel and concrete should be at least 10 times that of the specimen for the tests in paras 705, 722, 725(a), 727 and 735, and 100 times that of the specimen for the test in para. 737, unless a different value can be justified. The steel plate should have protruding fixed steel structures on its lower surface to ensure tight contact with the concrete. The hardness of the steel should be considered when testing packages with hard surfaces. To minimize flexure the concrete should be sufficiently thick, but still allowing for the size of the test sample. Other targets which have been used are described in the literature [7, 8]. Since flexure of the target is to be avoided, especially in the vertical direction, it is recommended that the target should be close to cubic in form with the depth of the target comparable to its width and length.

Test for packagings designed to contain uranium hexafluoride

718.1. For the hydraulic test, only the cylinder is tested; valves and other service equipment should not be included in this leakage test. The valves and other service equipment should be tested in consistency with ISO 7195 [9].

Tests for demonstrating ability to withstand normal conditions of transport

719.1. The climatic conditions to which a package may be subjected in the normal transport environment include changes in humidity, ambient temperature and pressure, and exposure to solar heating and rain.

719.2. Low relative humidity, particularly if associated with high temperature, causes the structural materials of the packaging such as timber to dry out, shrink, split and become brittle; direct exposure of a package to the sun can result in a surface temperature considerably above ambient temperature for a few hours around midday. Extreme cold hardens or embrittles certain materials, especially those used for joining or cushioning. Temperature and pressure changes can cause ‘breathing’ and a gradual increase of humidity inside the outer parts of the packaging, and if the temperature falls low enough, it can lead to condensation of water inside the packaging; the humidity in a ship’s hold is often high, and a fall in temperature will lead to considerable condensation on the outer surfaces of the package. If condensation occurs, fibreboard outer cases and spacers provided to reduce external radiation levels may collapse. Exposure to rain may occur while a package is awaiting loading or while it is being moved and loaded onto a conveyance.

719.3. A package may also be subjected to both dynamic and static mechanical effects during normal transport. The former may comprise limited shock, repeated bumping and/or vibration; the latter may comprise compression and tension.

719.4. A package may suffer a limited shock from a free drop onto a surface during handling. Rough handling, particularly rolling of cylindrical packages and tumbling of rectangular packages, is another common source of limited shock. It may also occur as a result of penetration by an object of relatively small cross-sectional area or by a blow from a corner or edge of another package.

719.5. Land transport often causes repeated bumping; all forms of transport produce vibrational forces which can cause metal fatigue and/or loose nuts and bolts. Stacking of packages for transport and any load movement as a result of a rapid change in speed during transport can subject packages to considerable compression. Lifting and a decrease in ambient pressure due to changes in altitude expose packages to tension.

719.6. The tests that have been selected to reproduce the kind of damage that could result from exposure to these climatic and handling/transport conditions and stresses are: the water spray test, the free drop test, the stacking test and the penetration test. It is unlikely that any one package would encounter all of the rough handling or minor mishaps represented by the four test requirements. The unintentional release of part of the contents, though very undesirable, should not be a major mishap because of the limitation on the contents of a Type A package. It is sufficient for one each of three specimens to be subjected separately to the free drop, stacking and penetration tests, preceded in each case by the water spray test. However, this does not preclude one specimen from being used for all the tests.

719.7. The tests do not include all the events of the transport environment to which a Type A package may be subjected. They are, however, deemed adequate when considered in relation with the other general design requirements related to the transport environment, such as ambient temperature and its variation, handling and vibration.

720.1. If the water spray is applied from four directions simultaneously, a two hour interval between the water spray test and the succeeding tests should be observed. This interval accounts for the time that it takes for the water to gradually soak from the exterior into the interior of the package and lower its structural strength. If the package is then submitted to the succeeding free drop, stacking and penetration tests shortly after this interval, it will suffer the maximum damage. However, if the water spray is applied from each of the four directions consecutively, soaking of water into the interior of the package from each direction and drying of water from the exterior of the package will proceed progressively over a period of two hours. Accordingly, no interval between the conclusion of the water spray test and the succeeding free drop test should be allowed.

721.1. The water spray test is primarily intended for packagings relying on materials that absorb water or are softened by water, or materials bonded by water soluble glue. Packagings whose outer layers consist entirely of metal, wood, ceramic or plastic, or any combination of these materials, may be shown to pass the test by reasoned argument providing that they do not retain the water and significantly increase their mass.

721.2. One method of performing the water spray test which is considered to satisfy the conditions prescribed in para. 721 is as follows:

- (a) The specimen is placed on a flat horizontal surface, in whichever orientation is likely to cause most damage to the package. A uniformly distributed spray is directed onto the surface of the package for a period of 15 min from each of

four directions at right angles, and changes in spray direction should be made as rapidly as possible. More than one orientation may need to be tested.

- (b) The following additional test conditions are recommended for consideration:
 - (i) A spray cone apex angle sufficient to envelop the entire specimen at the distance employed in (ii);
 - (ii) A distance from the nozzle to the nearest point on the specimen of at least 3 m;
 - (iii) A water consumption equivalent to the specified rainfall rate of 5 cm/h, as averaged over the area of the spray cone at the point of impingement on the specimen and normal to the centre line of the spray cone;
 - (iv) Water draining away as quickly as delivered.
- (c) The requirement of para. 721 is intended to provide maximum surface wetting, and this may be accomplished by directing the spray downwards at an angle of 45° from the horizontal:
 - (i) For rectangular specimens, the spray may be directed at each of the four corners;
 - (ii) For cylindrical specimens standing on one plane face, the spray may be applied from each of four directions at intervals of 90°.

721.3. The package should not be supported above the surface, in order to account for water that can be trapped at the base of the package.

722.1. The free drop test simulates the type of shock that a package would experience if it were to fall off the platform of a vehicle or if it were dropped during handling. In most cases packages would continue the journey after such shocks. Since heavier packages are less likely to be exposed to large drop heights during normal handling, the free drop distance for this test is graded according to package mass. If a heavy package experiences a significant drop, it should be examined closely for damage or loss of contents or shielding. Light packages made from materials such as fibreboard or wood require additional drops to simulate repeated impacts due to handling. It should be noted that, for packages containing fissile material, the requirement for additional free drop tests from a height of 0.3 m on each corner or, in the case of a cylindrical package, onto each quarter of each rim [para. 622(b) of the As Amended 1990 edition of the Regulations] has been deleted from the 1996 edition because such packages of metallic construction are not considered vulnerable to cumulative damage in the same way as certain lightweight wooden or fibreboard packages. Any inadequacies in a fissile package design with respect to its ability to withstand normal handling would be revealed by the test of para. 722. The additional 0.3 m free drop tests still apply to certain wooden or fibreboard packages, in the 1996 edition of the Regulations, whether or not they contain fissile material. This introduces a measure of consistency into the package testing regime.

722.2. Any drop test should be conducted with the contents of the package simulated to its maximum weight. More than one drop may be necessary to evaluate all possible drop attitudes. It may also be necessary to test specific features of the package such as hinges or locks to ensure that containment, shielding and nuclear criticality safety are maintained.

722.3. The features to be tested depend on the type of package to be tested. Such features include structural components, materials and devices designed to prevent loss or dispersal of radioactive substances or loss of shielding materials (e.g. the entire containment system, such as lids, valves and their seals). For packages containing fissile materials, the features could include, in addition to those mentioned above, components for maintaining subcriticality, such as a fuel holding frame and neutron absorbers.

722.4. The 'maximum damage' is the maximum impairment of the integrity of the package. To produce the 'maximum damage' for most packages, the specimen should be dropped in one or more attitudes in such a way that the impact acceleration and/or deformation of the components under consideration is maximized. Most containers have some asymmetry giving different resistance to impact. In any investigation, sufficient structural elements should be considered to allow for the absorption of all the kinetic energy of the package. Arguments should be developed as to the damage in the various elements between the impact point and the concentration of mass with regard to their performance in absorbing the energy, in developing internal loads, in distorting, collapsing or folding, and in the consequences of these behaviours.

722.5. Packages of low mass might be hand held above the target and dropped, provided the desired attitude can be maintained. In all other cases, mechanical means should be devised to hold and release the package in the desired impact attitude. This could be simply a release mechanism suspended from an overhead structure, like a roof member or a crane, or a tower specially designed for drop tests. The design of dedicated drop facilities has four main elements: the support, the release, the track guide (usually not used in direct drops), and the target which is defined in para. 717. Sufficient height is required in the support to allow for the release mechanism, the support cable or harness and the full depth of the test item and still make it possible to attain the correct attitude and dropping height between the bottom of the package and the target. In the case where a package has impact limiters, the lowest point of the impact limiter would be used to determine the drop height. The release mechanism for a free drop test should allow easy setting and instantaneous release, but should not give undesirable effects on the attitude of the specimen, and should not add to the mechanical damage to the specimen. Various types of mechanism, such as mechanical or electromagnetic, or combinations of mechanisms could be used. A number of test

facilities are described in IAEA-TECDOC-295 [10] and in the Directory of Test Facilities for Radioactive Materials Transport Packages published in the International Journal of Radioactive Materials Transport [11].

722.6. During the revision process leading to the 1996 edition of the Regulations, it was agreed that all possible drop test orientations need not be considered when conducting the drop test for normal conditions of transport. Providing that it is not possible under 'normal' conditions for the package to be dropped in certain orientations, these orientations could be ignored in assessing the worst damage. It was envisaged that this relaxation would only be allowed for large dimension and large aspect ratio packages. In addition this relief would require documented justification by the package designer. Package designs requiring approval by the competent authority should be tested in the most damaging drop test attitudes, irrespective of package size or aspect ratio.

722.7. Scale model techniques may be useful in order to determine the most damaging drop attitude (see paras 701.7–701.25). Care should be taken in instrumentation since mounts and sensor frequencies may produce errors in the data obtained.

723.1. The stacking test is designed to simulate the effect of loads pressing on a package over a prolonged period of time to ensure that the effectiveness of the shielding and containment systems will not be impaired and, in the case of the contents being fissile material, will not adversely affect the configuration. This test duration corresponds to the requirements of the United Nations Recommendations [12].

723.2. Any package whose normal top, i.e. the side opposite the one which it normally rests on, is parallel and flat, could be stacked. In addition, stacking could be achieved by adding feet, extension pads or frames to the package with convex surfaces. Packages with convex surfaces cannot be stacked unless extension pads or feet are provided.

723.3. The specimen should be placed with the base down on an essentially flat surface such as a flat concrete floor or steel plate. If necessary, a flat plate, which has sufficient area to cover the upper surface of the specimen, should be placed on the upper surface of the specimen so that the load may be applied to it uniformly. The mass of the plate should be included in the total stacking mass being applied. If a number of packages of the same kind are stackable, a simple method is to build a stack of five packages on top of the test specimen. Alternatively, a steel plate or plates or other convenient materials with a mass five times that of the package may be placed on the package.

724.1. The penetration test is intended to ensure that the contents will not escape from the containment system or that the shielding or confinement system would not be damaged if a slender object such as a length of metal tubing or a handlebar of a falling bicycle should strike and penetrate the outer layers of the packaging.

Additional tests for Type A packages designed for liquids and gases

725.1. These additional tests for a Type A package designed to contain liquids or gases are imposed because liquid or gaseous radioactive material has a greater possibility of leakage than solid material. These tests do not require the water spray test first.

Tests for demonstrating ability to withstand accident conditions of transport

726.1. The accident tests specified in the Regulations were originally developed to satisfy two purposes. First, they were conceived as producing damage to the package equivalent to that which would be produced by a very severe accident (but not necessarily all conceivable accidents). Second, the tests were stated in terms which provided the engineering basis for the design. Since analysis is an acceptable method of qualifying designs, the tests were prescribed in engineering terms which could serve as unambiguous, quantifiable input to these calculations. Thus, in the development of the test requirements attention was given to how well these tests could be replicated (see, for example, para. 717.1).

726.2. The 1961 edition of the Regulations was based on the principle of protection of the package contents, and hence the public health, from the consequences of a 'maximum credible accident'. This phrase was later dropped because it did not give a unique level or standard with which to work and which was necessary to ensure the international acceptability of unilaterally approved designs. Recognition of the statistical nature of accidents is now implicit in the requirements. A major aim of the package tests is international acceptability, uniformity and repeatability; tests are designed so that the conditions can be readily reproduced in any country. The test conditions are intended to simulate severe accidents in terms of the damaging effects on the package. They will produce damage exceeding that arising in the vast majority of incidents recorded, whether or not a package of radioactive material was involved.

726.3. The purpose of the mechanical tests (para. 727) and the thermal test (para. 728) that follow is to impose on the package damage equivalent to that which would be observed if the package were to be involved in a severe accident. The order and type of tests are considered to correspond to the order of environmental threat to the packaging in a real transport accident, i.e. mechanical impacts followed by thermal

exposure. The test sequence also ensures mechanical damage to the package prior to the imposition of the thermal test; thus the package is most liable to sustain maximum thermal damage. The mechanical and thermal tests are applied to the same specimen sequentially. The immersion test (para. 729) may be conducted on a separate specimen because the probability of immersion occurring in conjunction with a thermal/mechanical accident is extremely low.

727.1. Mechanical test requirements for Type B packages were introduced in the 1964 edition of the Regulations, replacing the requirement of withstanding a ‘maximum credible accident’, which was not specified by specific test requirements but left to the competent authority of the country concerned. Since Type B(U) and Type B(M) packages are transported by all modes of transport, the Type B(U) and Type B(M) test requirements are intended to take into account a large range of accidents which can expose packages to severe dynamic forces. The mechanical effects of accidents can be grouped into three categories: impact, crush and puncture loads. Though the figures for the test requirements were not derived directly from accident analyses at that time, subsequent risk and accident analyses have demonstrated that they represent very severe transport accidents [13–18].

727.2. In drop I, the combination of the 9 m drop height, unyielding target and most damaging attitude produces a condition in which most of the drop energy is absorbed in the structure of the packaging. In real transport accidents, targets such as soil or vehicles will yield, absorbing part of the impact energy, and only higher velocity impacts may cause equivalent damage [16–18].

727.3. Thin walled packaging designs or designs with sandwich walls could be sensitive to puncture loads with respect to loss of containment integrity, loss of thermal insulation or damage to the confinement system. Even thick walled designs may have weak points such as closures of drain holes, valves, etc. Puncture loads could be expected in accidents as impact surfaces are frequently not flat. In order to provide safety against these loads, the 1 m drop test onto a rigid bar was introduced. The drop height and punch geometry parameters are more the result of an engineering judgement than deductions from accident analyses.

727.4. The degree of safety provided by the 9 m drop test is smaller for light, low density packages than for heavy, high density packages, owing to the reduced impact energy and to the increased probability of impacting a relatively unyielding ‘target’ [16–22]. Such packages may also be sensitive to crush loads. Accident analyses show that the probability of dynamic crush loads in land transport accidents is higher than that of impact loads because lightweight packages are transported in larger numbers or together with other packages [13–15]. Also, handling and stowage mishaps can

lead to undue static or dynamic crush loads. The end result of this was the inclusion of the crush test (drop III) in the 1985 edition of the Regulations. Packages containing a large amount of alpha emitters are generally light, low density packages due to their limited shielding, and may fit into this category. This includes, for example, plutonium oxide powders and plutonium nitrate solutions, which are radioactive materials with high potential hazards. Because of their physical characteristics, most packages will be subject to the 9 m drop (impact) test rather than the crush test.

727.5. The Regulations require that the attitudes of the package for both the impact (drop I) or crush (drop III) and the penetration (drop II) tests be such as to produce maximum damage, taking into account the thermal test. In addition, the order in which the tests are carried out is that which will be most damaging. The assessment of maximum damage should be made with concern for the containment of the radioactive material within the package, the retention of shielding to keep external radiation to the acceptable level and, in the case of fissile materials, maintenance of subcriticality. Any damage which would give rise to increased radiation or loss of containment, or affect the confinement system after the thermal test, should be considered. Damage which may render the package inappropriate for reuse but does not affect its ability to meet the safety requirements should not be a reason for classifying the specimen as having failed.

727.6. Different modes of damage are possible as a result of the mechanical tests. It is necessary to consider the results of these modes for any analytical assessment to demonstrate compliance with the applicable requirements. The fracture of a critical component or the breach of the containment system may allow the escape of the radioactive material. Deformation may impair the function of radiation or thermal shields and may alter the configuration of fissile material and it should be reflected in the assumptions and predictions in the criticality assessment. Local damage to shielding may, as a result of the subsequent thermal test, give rise to deterioration of both thermal and radiation protection. Consequently, investigations should include stress, strain, instability and local effect for all attitudes of drop where symmetry does not prevail.

727.7. Multiple drops of a specimen for the same test may not be feasible because of previous damage. It may be necessary to use more than one test sample or use analysis and reasoned argument based on engineering data to predict the most damaging attitude and to eliminate testing those attitudes where the safety is not impaired.

727.8. The most severe attitudes for symmetric packagings that have either a cylindrical or cubic form may often be determined by the use of published information [10, 23]. Asymmetries, especially where protrusions occur, are often sensitive when used

as the impact point. Lifting and handling devices such as skids or attachment points will often have a different strength or stiffness relative to the adjacent parts of the package and should be considered as possible impact points.

727.9. Discontinuities such as the lid or other penetration attachments could give a locally stiff element of structure of limited strength which could fail by either adjacent structural deformation or high loading (due to decelerations) on their retained masses.

727.10. Thin wall packages, such as drums, should be considered in terms of the possibility of plastic deformation either causing loss of the containment seal or distorting the lid attachment sufficiently to allow the loss of the lid.

727.11. Paragraph 671 requires that, for fissile materials, criticality analyses be made with the damage resulting from the mechanical and thermal tests included. Consideration is required of such aspects as efficiency of moderator, loss of neutron absorbers, rearrangement of package contents, geometric changes and temperature effects. The assumptions made in the criticality analysis should be in conformity with the effects of the mechanical and thermal tests, and all package orientations should be considered for the analysis.

727.12. It is intended that the drop of the package (drops I and II) or of the 500 kg mass (drop III) should be a free fall under gravity. If, however, some form of guiding is used, it is important that the impact velocity should be at least equal to the impact velocity where the package or the mass is under free fall (approx. 13.3 m/s for drops I and III).

727.13. For drop II, the required minimum length of the penetrating bar is 20 cm. A longer bar length should be used when the distance between the outer surface of a package and any inner component important for the safety of the package is greater than 20 cm or when the orientation of the model requires it. This is particularly true for specimens with large impact limiting devices, where the penetration can be considerable. The material specified for the construction of the bar is mild steel. The minimum yield stress of such material should not be less than 150 MPa nor more than 280 MPa. The yield to ultimate stress ratio should not be greater than 0.6. It may be difficult to perform a test where buckling of the bar is possible. In this case, justification of the bar length to obtain maximum damage to the specimen should be carried out.

727.14. For drop II, the most damaging package orientation is not necessarily a flat impact onto the bar top surface. For some package designs it has been shown that oblique orientations at angles in the range of 20–30° cause maximum damage

because of the initiation of penetration of the bar corner into the external envelope of the package.

727.15. For preliminary design purposes only, for the outer shell of a steel–lead–steel packaging, the following equation may be used to estimate the shell thickness required to resist failure when the package is subjected to the penetration test:

$$t = 2148.5 \left(\frac{w}{s} \right)^{0.7}$$

where

t is the outer shell thickness (cm),

w is the mass of the package (kg), and

s is the tensile strength of the outer shell material (Pa).

This equation is based on tests employing annealed mild steel backed by chemical lead [23]. Packages using materials having different physical properties could require different thicknesses of the outer steel shell to meet the requirements. For packages with small diameters, less than 0.75 m, or using materials having different physical properties, or for impacts near changes of geometry or in oblique attitudes, the preliminary estimate may not be conservative [23].

727.16. For the crush test (drop III) the packaging should rest on the target in such a way that it is stable. To achieve this it may be necessary to provide support, in which case the presence of the support should not influence the damage to the package [24].

727.17. Instrumentation of test specimens and even of the target response to impact should be done for the following reasons:

- validation of assumptions in the safety analysis,
- as a basis for design alterations,
- as a basis for the design of comparable packages,
- as a benchmark test for computer codes.

727.18. Examples of functions that should be measured under impact/crushing conditions are: deceleration–time function and strain–time function. Where electronic devices are used to acquire, record and store data, examination of any filtering, truncating or cropping should be made so that no data peaks of significance are lost. Most instruments will require cable connections to external devices. These connections should be such that they neither restrict the free fall of the package nor restrain the package in any way after impact (see para. 701.9).

728.1. Work in the USA [13–15, 25–28] suggests that the thermal test specified in para. 728 provides an envelope of environments which encompasses most transport related accidents involving fires. The Regulations specify a test condition based on a liquid hydrocarbon–air fire with a duration of 30 min. Other parameters relating to fire geometry and heat transfer characteristics are specified in order to define the heat input to the package.

728.2. The thermal test specifies a liquid hydrocarbon pool fire which is intended to encompass the damaging effects of fires involving liquid, solid or gaseous combustible materials. Liquids such as liquid petroleum gas (LPG) or liquid natural gas (LNG) and liquid hydrogen are covered by the test because pool fires with such fuels generally will not last for 30 min. Liquid petroleum products are frequently transported by road, rail and sea and would be expected to give rise to a fire following an accident. Liquids that can flow around the package and create the stipulated conditions are restricted to a narrow range of calorific values, so the severe fire is quite well defined.

728.3. The flame temperature and emissivity (800°C and 0.9) define time and space averaged conditions found in pool fires. Locally, within fires, temperatures and heat fluxes can exceed these values. However, non-ideal positioning of a package within a fire, the movement with time of the fire source relative to the package, shielding by other non-combustible packages or conveyances involved in the accident, wind effects and the massive structure of many Type B(U) and Type B(M) packages will all combine to average the conditions to conform to, or be less severe than, the test description [27, 28]. The presence of a package and remoteness from the oxygen supply (air passing through about 1 m of flame) may both tend to depress the flame temperature adjacent to the package. Natural winds can supply extra oxygen but tend to remove flame cover from parts of the package, hence the requirement of quiescent ambient conditions. Use of a vertical flame guide underneath the package will minimize the effect of wind and improve flame coverage [29]. The flame emissivity is difficult to assess, as direct measurements are not generally available, but indications from practical tests suggest that the 0.9 value specified is an overestimate. The combination of parameters in the test results in severe flame conditions is unlikely to be exceeded by accident conditions.

728.4. The duration of a large petroleum fire depends on the quantity of fuel involved and the availability of fire fighting resources. Liquid fuel is carried in large quantities but, in order to form a pool, any leakage must flow into a well defined area around the package with consequent losses by drainage. In general, not all the contents of a single tank will be involved in this way as much will be consumed either in the tank itself or during transfer to the vicinity of the package. The contents of other

tanks will most likely be burnt at a more remote location as the fire moves from tank to tank. Recognition must also be given to the fact that, when lives are not directly at risk, fires are often allowed to continue to natural extinction. Consequently, historical records of fire durations should be viewed critically. The 30 min duration is therefore chosen from consideration of these factors and encompasses the low probability of a package being involved in a fire with a large volume of fuel and the ‘worst case’ geometry specified. The low probability, long duration fire is most likely to occur in combination with a geometry which effectively reduces the thermal input, with the package resting on the ground and/or protected by the vehicle structure. The heat input from the thermal test is thus consistent with realistic, severe accident situations.

728.5. The following configuration for the fire geometry minimizes the effects of radiation losses and maximizes heat input to the packages. A 0.6–1 m elevation of the package ensures that the flames are well developed at the package location, with adequate space for the lateral in-flow of air. This improves flame uniformity without affecting the heat fluxes. The extension of the fuel source beyond the package boundary ensures a minimum flame thickness of about 1 m, providing a reasonably high flame emissivity. The size of the pool should be between 1 and 3 m beyond any external surface of the test specimen to improve flame coverage. Larger extensions can lead to oxygen starvation at the centre and relatively low temperatures close to the package [30].

728.6. Previous editions of the Regulations required that no artificial cooling be used before three hours have expired following cessation of the fire. The 1985 edition deleted reference to the three hour period, implying that the assessment of temperatures and pressures should continue until all temperatures, internal and external, are falling and that natural combustion of package components will continue without interference. Only natural convection and radiation contribute to heat loss from the package surface after the end of the fire.

728.7. The Regulations allow other values of surface absorptivity to be used as an alternative to the standard value of 0.8 if they can be justified. In practice, a pool fire is so smoky that it is probable that soot will be deposited on cool surfaces, modifying conditions there. This is likely to increase the absorptivity but interpose a conduction barrier. The value of 0.8 is consistent with thermal absorptivities of paints and can be considered as approximating the effects of surface sooting. As a surface is heated, the soot may not be retained, and lower values of surface absorptivity could result.

728.8. The 1985 edition of the Regulations removed the previous ambiguity of “convection heat input in still ambient air at 800°C” but did not specify a value for the coefficient, requiring the designer to justify the assumptions. A significant

proportion of the heat input may derive from convection, particularly when the outer surface is finned and early in the test when the surfaces are relatively cool. The convective heat input should be at least equivalent to that for a hydrocarbon fuel air fire at the specified conditions.

728.9. The effects of the thermal test are, of course, dominated by increased package temperatures and consequent effects such as high internal pressures. The peak temperature depends to some extent on the initial temperature, which should therefore be determined using the highest appropriate initial conditions of internal heat generation, solar heating and ambient temperature. For a practical test, not all of these initial conditions will be achievable, so appropriate measurements (e.g. ambient temperature) should be made, and package temperatures corrected after the test.

728.10. The fire conditions defined in the Regulations and the requirement for full engulfment for the duration of the test represent a very severe test of a package. It is not intended to define the worst conceivable fire. In practice, some parameters may be more onerous than specified in the Regulations but others would be less demanding. For example, it is difficult to conceive of a practical situation where all surfaces of a package could experience the full effects of the fire, since it would be expected that a significant fraction of the surface area would be shielded, either by the ground or by wreckage and debris arising from the accident. Emphasis has been placed on the thermal heat flux rather than on the individual parameters chosen, and in this respect the conditions specified represent a very severe test for any package [28]. It should also be emphasized that the thermal test is only one of a cumulative series of tests which must be applied to yield the maximum damage in a package. This damage must remain demonstrably small in terms of stringent criteria of containment integrity, external radiation level and nuclear criticality safety.

728.11. The following are examples that are recommended. Other methods or techniques may be used but more justification might be expected in support of such an approach. It is important to note that the requirements of the thermal test may be met by a practical test, by a calculated assessment, or by a combination of both. The last approach may be necessary if, for example, the initial conditions required for a practical test were not achieved or if all the package design features were not fully represented in the experiment. In many cases, the consequences of the thermal test need to be determined by calculation, which therefore becomes an integral part of the planning and execution of the practical test. The Regulations specify certain fire parameters which are essential input data for the calculation method but are generally uncontrollable parameters in practical tests. Standardization of the practical test is therefore achieved by defining the fuel and test geometry for a pool fire and requiring other practical methods to provide the same or greater heat input.

728.12. With regard to the package design, some shielding materials have eutectics with melting temperatures which are lower than the 800°C environment of the thermal test. Therefore consideration should be given to the capability of any structural materials to retain them. Local shielding materials such as plastics, paraffin wax or water may vaporize, causing a pressure which may rupture a shell that may have been weakened by damage from the mechanical tests. A thermal analysis may be required to determine whether such pressures can be attained.

728.13. The bottom of the package to be tested should be between 0.6 and 1 m above the surface of the liquid fuel source. Unless the fuel is replenished, or replaced by another liquid such as water, the level will fall during the test, probably by about 100 to 200 mm. The specimen package should be supported in such a way that the flow of heat and flames is perturbed by the minimum practical amount. For example, a larger number of small pillars is to be preferred to a single support covering a large area of the package. The transport vehicle, and any other ancillary equipment which might protect the package in practice, should be omitted from this test as the protection was taken into account in the test definition.

728.14. The pool size should extend between 1 and 3 m beyond the edges of the package so that all sides of the package are exposed to a luminous flame not less than 0.7 m and not more than 3 m thick, taking into account the reduction of the flame thickness with increasing height over the pool. In general, larger packages will require a larger extension as flame thicknesses will vary more over the greater distances involved. The requirement for fully engulfing flames can be interpreted as a need for all parts of the package to remain invisible throughout the 30 min test, or at least for a large proportion of the time. This is best achieved by designing for thick flame cover which can accommodate natural variations in thickness without becoming transparent. A low wind velocity (quiescent conditions) is also required for stable flame cover, although large fires might generate high local wind velocities. Wind screens or baffles can help to stabilize the flames, but care should be taken to avoid changing the character of the flames and to avoid reflected or direct radiation from external surfaces. This would enhance the heat input and therefore not invalidate the test, but could make it more stringent than necessary.

728.15. Wind speeds of less than about 2 m/s should not detract from the test, and short duration gusts of higher speeds will not have a large effect on high heat capacity packages, particularly if flame cover is maintained. Open air testing should only take place when rain, hail or snow will not occur before the end of the post-fire cool-down period. The package should be mounted with the shortest dimension vertical for the most uniform flame cover, unless a different orientation will lead to a higher heat input or greater damage, in which case such an arrangement should be chosen.

728.16. The fuel for a pool fire should comprise a distillate of petroleum with a distillation end point of 330°C maximum and an open cup flash point of 46°C minimum, and with a gross heating value of between 46 and 49 MJ/kg. This covers most hydrocarbons derived from petroleum with a density of less than 820 kg/m³, e.g. kerosene and JP4 type fuels. A small amount of more volatile fuel may be used to ignite the pool as this will have an insignificant effect on the total heat input.

728.17. The choice of instrumentation will be dictated by the use to be made of a practical thermal test. Where a test provides data to be used in calculations to demonstrate compliance, some instrumentation is essential. The type and positioning of the instruments will depend on the data needed, e.g. internal pressure and temperature measurements may be necessary and, where stress is considered important, strain gauges should be installed. In all cases, the cables carrying signals through the flames should be protected to avoid extraneous voltages created at high temperatures. As an alternative to continuous measurement, the package might be equipped in such a way that instruments could be connected soon after the fire and early enough to measure the peak pressure and temperature. A measurement of leakage can be achieved by pre-pressurization and re-measurement after the thermal test, where necessary making appropriate adjustments for temperature (see paras 656.5–656.24).

728.18. The duration of the test can be controlled by providing a measured supply of fuel calculated to ensure the required 30 min duration, by removing the supply of fuel a predetermined time before the end of the test, by discharging the fuel from the pool at the end of the test or by carefully extinguishing the fire without affecting the package surfaces with the extinguishing agent. The duration of the test is the time between the achievement of good flame cover and required flame temperatures, and the time at which such cover and temperature are lost.

728.19. Measurements should continue after the fire, at least until the internal temperatures and pressures are falling. If rain, or other precipitation, occurs during this period, a temporary cover should be erected to protect the package and to prevent inadvertent extinguishing of combustion of the package materials, but care should be taken not to restrict heat loss from the package.

728.20. Where the test supplies data for an analytical evaluation of the package, measurements made during the test should be corrected for non-standard initial conditions of ambient temperature, insolation, internal heat load, pressure, etc. The effects of partial loading, i.e. less than full contents, on the package heat capacity and heat transfer should be assessed.

728.21. A furnace test is often more convenient than an open pool fire test. Other possible test environments include pit fires and an open air burner system operating with liquefied petroleum gas [31]. Any such test is acceptable provided it meets the requirements of para. 728. Methods to verify the required heat input and methods to prove the thermal environment can be found in the literature [32–34].

728.22. Requiring that the internal temperature increase be not less than that predicted for an 800°C fire ensures that the heat input is satisfactory. However, the test should continue for at least 30 min, during which the time averaged environment temperature should be at least 800°C. A high emissivity radiation source should be created by selecting a furnace either with an internal surface area very much larger than the envelope area of the package or with an inherently high emissivity internal surface (0.9 or higher). Many furnaces are unable to reproduce either the desired emissivity or the convective heat input of a pool fire, so an extension of the test duration might be necessary to compensate. Alternatively, a higher furnace temperature can be used but the test duration should be a minimum of 30 min. The furnace wall temperature should be measured at several places, sufficient to show that the average temperature is at least 800°C. The furnace can be preheated for a sufficient time to achieve thermal equilibrium, so avoiding a large temperature drop when the package is inserted. The 30 min minimum duration should be such that the time averaged environment temperature is at least 800°C.

728.23. The calculation of heat transfer or the determination of physical and chemical changes of a full size package based on the extrapolation of the results from a thermal test of a scale model may be impossible without many different tests. A wide ranging programme simulating each process separately would require an extensive investigation using a theoretical model, so the technique has little inherent advantage over the normal analytical approach. Any scale testing, and the interpretation of the results, should be shown to be technically valid. However, the use of full scale models of parts of the package might be useful if calculation for a component (such as a finned surface) proves difficult. For example, the efficiency of a heat shield, or of a shock absorber acting in this role, could be most readily demonstrated by a test of this component with a relatively simple body beneath it. Component modelling is of importance for the validation of computer models. However, measurements of flame temperature and flame and surface emissivities are difficult and might not provide a sufficiently accurate specification for a validation calculation. Component size should be selected and appropriate insulation provided so that heat entering from the artificial boundaries (i.e. those representing the rest of the package) is not significant.

728.24. Thermal testing of reduced scale models meeting the specified conditions of the thermal test may be performed and lead to conservative results of temperatures

assuming that there is no fundamental change in the thermal behaviour of the components.

728.25. The most common method of package assessment for the thermal test is calculation. Many general purpose, heat transfer computer codes are available for such package modelling, although care should be taken to ensure that the provisions available in the code, in particular for representing radiation heat transfer from the environment to external surfaces, are adequate for the package geometry. Practical tests may ultimately be required for validation but arguments showing that the approximations or assumptions produce a more stringent test than required are often used. In general, code validation is accomplished by comparison with analytical solutions and comparison with other codes.

728.26. Generally, the normal conditions of transport will have been assessed by calculation, so detailed temperature and pressure distributions should be available. Alternatively, the package temperatures might have been measured experimentally, so that, after correction to the appropriate ambient temperature and for the effects of insolation and the heat load due to the contents, these provide the initial conditions for the calculated thermal test conditions. Ambient temperature corrections can be made in accordance with para. 651.4.

728.27. The external boundary conditions of the fire should represent radiation, reflection and convection. The temperature is specified by the Regulations as an average of 800°C, so, in general, a uniform average temperature of 800°C should be used for the radiation source and for convective heat transfer.

728.28. The flame emissivity is prescribed as 0.9. This can be used without ambiguity for plane surfaces but, for finned surfaces, the thin flames between the fins will have an emissivity much lower than that value. The dominant source of radiation to the finned surfaces will therefore be the flames outside the fins; radiation from flames within the fin cavity can be ignored. In all cases, appropriate geometric view factors should be used with the fin envelope radiation source, and reflected radiation should be taken into account. Care should be taken to avoid the inclusion of radiation 'reflected' from a surface representing flames as this is a non-typical situation.

728.29. The surface absorptivity is prescribed as 0.8 unless an alternative value can be established. In practice, demonstration of alternative values will be extremely difficult as surface conditions change in a fire, particularly as a result of sooting, and evidence obtained after a fire may not be relevant. The value of 0.8 is therefore most likely to be used in analytical assessments. It is important to take into account reflected radiation, particularly with complex finned surfaces, as multiple reflections increase

the effective absorptivity to near unity. This complexity can be avoided by assuming unity for the surface absorptivity but, even in this case, surface to surface radiation should not be ignored, particularly during the cool-down period.

728.30. Convection coefficients during the fire should to be justified. Pool fire gas velocities are generally found to be in the range of 5–10 m/s [35]. Use of such velocities in forced convection, heat transfer correlations (e.g. the Colburn relation $Nu = 0.036 Pr^{1/3} Re^{0.8}$ quoted by McAdams [36]) results in convective heat transfer coefficients of about $10 \text{ W/m}^2\cdot\text{°C}$ for large packages. Natural convection coefficients (about $5 \text{ W/m}^2\cdot\text{°C}$) are not appropriate as this implies downward gas flow adjacent to the cool package walls, whereas, in practice, a general buoyant upward flow will dominate. The upper surface of a package is unlikely to experience such high gas velocities, in quiescent atmospheric conditions, as the region will include a stagnation area in the lee of the upward gas flow. The reduced convection there is adequately represented by the average coefficient as the averaging process includes this effect.

728.31. Convection coefficients for the post-test, cool-down period can be obtained from standard natural convection references, e.g. McAdams [36]. In this case coefficients appropriate for each surface can readily be applied. For vertical planes the turbulent natural convection equation is given by

$$Nu = 0.13 (Pr \cdot Gr)^{1/3}$$

for Grashof numbers $>10^9$. The boundary conditions used for the assessment of conditions under normal operation should be used. Changes to surface conditions and/or geometry resulting from the fire should be recognized in the post-fire assessment as these might affect both radiation and convection heat losses. Allowance should be made for continued heat input if package components continued to burn following the thermal test exposure.

728.32. Consideration should be given to the proper modelling of any thermal shields such as impact limiters that are affected after the mechanical tests stated in para. 727. Some examples are: changes in shape/dimensions, changes in material densities due to compaction, and separation of the thermal shield.

728.33. Calculations that are performed using finite difference or finite element models should have a sufficiently fine mesh or element distribution to properly represent internal conduction and external and internal boundary conditions. External features such as fins should be given special attention as temperature gradients can be severe, perhaps requiring separate detailed calculations in order to determine the heat flux to the main body. Consideration should be given to the choice of one, two or

three dimensional models and to the decision whether the whole package or separate parts are to be evaluated.

728.34. External surfaces of low thermal conductivity can lead to oscillations in computed temperatures. Special techniques (e.g. simplified boundary conditions) or assumptions (e.g. that time averaged temperatures are sufficiently accurate) might be necessary to deal with this.

728.35. Generally, conduction and radiation can be modelled explicitly and external convection provides few problems for general purpose computer codes but experimental evidence may be required to support modelling assumptions and basic data used to represent internal convection and radiation. Radiation reflection will be important in gas filled packages, and insufficient knowledge of thermal emissivities may restrict the final accuracy. A sensitivity study with different emissivities can be used to show that the assumptions are adequate or to provide conservative (i.e. maximum) limits on calculated temperatures.

728.36. Internal convection will be important for a water filled package and might be significant in a gas filled package. This process is difficult to predict unless there is experimental evidence to support modelling assumptions. Where water circulation routes are provided, internal heat dissipation will be rapid compared with other time constants and simplifying assumptions may be made (e.g., water can be modelled by an artificial material with high conductivity). Care should be taken to consider areas not subject to circulation (stagnant regions) as high temperatures can occur there because of the inherently low thermal conductivity of water.

728.37. Gas gaps and contact resistances can vary with the differential expansion of components and it is not always clear whether an assumption will yield high or low temperatures. For example, a high resistance gas gap will prevent heat flow, minimizing temperatures inside but maximizing other temperatures because of the reduced effective heat capacity. In such cases calculations based on two extreme assumptions might provide evidence that both conditions are acceptable and, by implication, all variations in between are also acceptable. The gaps and contact resistance in the test sample should be representative of future production. Seals are rarely represented explicitly, but local temperatures could be used as a close approximation to the temperature of the seals.

728.38. The calculation of a thermal test transient should include the initial conditions, 30 min with external conditions representing the fire and a cool-down period extending until all temperatures are decreasing with time. In addition, further calculation runs, perhaps with a different mesh distribution, should be performed to check the validity

of the model and to assess the uncertainties associated with the modelling assumptions.

728.39. The results of the analysis will be used to confirm that the package has adequate strength and that leakage rates will be acceptable. The determination of pressures from calculated temperatures is thus an important step, particularly where the package contains a volatile material such as water or UF₆. Items such as lead shields often may not be allowed to melt as the resulting condition cannot be accurately defined and thus shielding assessments may not be possible. Component temperatures, if necessary in connection with local hot spots, should be examined to ensure that melting or other modes of failure will not occur in the whole procedure. The uncertainties in the model, the data (e.g. manufacturing tolerances) and the limitations of the computer codes should be recognized, and allowances should be made for these uncertainties.

728.40. The post-exposure equilibrium temperatures and pressure might be affected by irreversible changes in the thermal test (perhaps due to protective measures such as the use of expanding coatings or the melting and subsequent relocation of lead within the package). These effects should be assessed.

729.1. As a result of transport accidents near or on a river, lake or sea, a package could be subjected to an external pressure from submersion under water. To simulate the equivalent damage from this low probability event, the Regulations require that a packaging be able to withstand external pressures resulting from submersion at reasonable depths. Engineering estimates indicated that water depths near most bridges, roadways or harbours would be less than 15 m. Consequently, 15 m was selected as the immersion depth for packages (it should be noted that packages containing large quantities of irradiated nuclear fuel should be able to withstand a greater depth (see para. 730)). While immersion at depths greater than 15 m is possible, this value was selected to envelop the equivalent damage from most transport accidents. In addition, the potential consequences of a significant release would be greatest near a coast or in a shallow body of water. The eight hour time period is sufficiently long to allow the package to come to a steady state from rate dependent effects of immersion (e.g. flooding of exterior compartments).

729.2. The water immersion test may be satisfied by immersion of the package, a pressure test of at least 150 kPa, a pressure test on critical components combined with calculations, or by calculations for the whole package. The entire package may not have to be subjected to a pressure test. Justification of model assumptions about the response of critical components should be included in the evaluation.

Enhanced water immersion test for Type B(U) and Type B(M) packages containing more than 10^5 A₂ and Type C packages

730.1. See paras 657.1–657.8, 729.1 and 729.2.

730.2. The water immersion test may be satisfied by the immersion of the package, a pressure test of at least 2 MPa, a pressure test on critical components combined with calculations, or by calculations for the whole package.

730.3. If calculational techniques are adopted it should be noted that established methods are usually intended to define material, properties and geometries which will result in a design capable of withstanding the required pressure loading without any impairment. In the case of the 200 m water immersion test requirement for a period of not less than one hour, some degree of buckling or deformation is acceptable provided the final condition conforms with para. 657.

730.4. The entire package does not have to be subjected to a pressure test. Critical components such as the lid area may be subjected to an external gauge pressure of at least 2 MPa and the balance of the structure may be evaluated by calculation.

Water leakage test for packages containing fissile material

732.1. This test is required because water in-leakage may have a large effect on the allowable fissile material content of a package. The sequence of tests is selected to provide conditions which will allow the free ingress of water into the package, together with damage which could rearrange the fissile contents.

733.1. The submersion test is intended to ensure that the criticality assessment is conservative. The sequence of tests prior to the submersion simulate accident conditions that a package could encounter during a severe accident near or on water in transport. The specimen is immersed in at least 0.9 m of water for a period of not less than eight hours.

Tests for Type C packages

734.1. The Regulations do not require the same specimen to be subjected to all the prescribed tests because no real accident sequence combines all the tests at their maximum severity. Instead, the Regulations require the tests to be performed in sequences that concentrate damage in a logical sequence typical of severe accidents; see IAEA-TECDOC-702 [37].

734.2. Different specimens may be subjected to the sequences of tests. Also the evaluation criterion for the water immersion test prescribed in para. 730 is different from the criterion for the other tests. The evaluation of the package with regard to shielding and containment integrity must be performed after completing each test sequence.

735.1. The possible occurrence of puncture and tearing is significant. However, the environment is qualitatively and quantitatively difficult to describe [38, 39]. Puncture damage could be caused by parts of the airframe and the cargo. Puncture on the ground is possible but considered to be of less importance.

735.2. A consequence of puncture can be a release from the package containment system, but this would have a very low probability of occurrence. A stronger concern is that of damage to the thermal insulation capability of a package, which would result in unsatisfactory behaviour should a fire follow impact.

735.3. The design of the test requires the definition of a probe with length, diameter, and mass; an unyielding target; and an impact speed. One possibility for specifying the probe was to refer to components of the aircraft. An I-beam has been incorporated in some tests or test proposals, but it was preferred to adopt a more conventional geometric object, namely, a right circular cone. This shape is considered to be one that could cause considerable damage. The height of fall or travelling distance of a probing structure in the range of a few metres is representative of the collapse of structures or bouncing within the aircraft.

735.4. Failure in engines can generate unconfined engine fragments at a rate that deserves consideration. Loss of the aircraft is only one among many possible consequences of the emission of missiles, which can be quite energetic (up to 10^5 J). However, the probability of a fragment hitting a package has been found to be very low in specific studies [37, 40, 41] and penetration probability, although not estimated, would be lower. Thus, on a probability basis, it was considered unnecessary to define a test to cover engine fragment damage.

735.5. For para. 735(a), the total length of the penetrator probe and details of its construction beyond the frustum are left unspecified but should be adjusted to assure that the mass requirement is attained. For para. 735(b) the penetrating object should be of sufficient length and mass to extend through the energy absorbing and thermal insulating materials surrounding the inner containment vessel, and should be of sufficient rigidity to provide a penetrating force without itself being crushed or collapsed. In both cases, centres of gravity of the probe and packaging should be aligned to preclude non-penetrating deflection [42].

735.6. See also para. 727 for additional information.

736.1. The duration of the fire test for air accident qualification was set at 60 min. Statistical data on fires resulting from air accidents support the conclusion that the 60 min thermal test exceeds most severe fire environments that a package would be likely to encounter in an aircraft accident. Fire duration statistics are frequently biased by the duration of burning of ground structures and other features not related to the aircraft wreckage, as well as by the location of consignments involved in the accident. To account for this effect, information on fire duration was evaluated carefully to avoid bias by accounts of fires that did not involve the aircraft. The fire test has the same characteristics as those specified in para. 728.

736.2. The importance of fireballs as a severe air accident environment was evaluated in setting the requirements of the fire test. Surveys have shown that 'fireballs' of short duration and high temperature occur commonly in the early stages of aircraft fires and are generally followed by a ground fire [43, 44]. The heat input to the package arising from fireballs is not significant compared with the heat input from the extended fire test. Consequently, no tests are required to evaluate a fireball's impact on package survival.

736.3. The presence of certain materials in an aircraft, for example, magnesium, could result in an intense fire. However, this is not considered to be a serious threat to the package because of the small quantities of such material that are likely to be present and the localized nature of such fires. Similarly, aluminium in large quantities is present in the form of fuselage panels. These panels will have melted away within a few minutes. It was not considered credible that aluminium would burn and increase package heat load greatly.

736.4. This test is not sequential to the 90 m/s impact speed test that is described in para. 737. In severe accidents, high speed impact and long duration fires are not expected to be encountered simultaneously because high velocity accidents disperse fuel and lead to non-engulfing, wider area fires of lower consequence. The Type C package must be subjected to an extended test sequence consisting of the Type B(U)/Type B(M) impact and crush tests (paras 727(a) and (c)), followed by the puncture/tearing test (para. 735) and completed by the enhanced thermal test (para. 736). It is considered that the additive combination of these tests provides protection against severe air accidents that could involve both impact and fire.

736.5. Account should be taken of melting, burning, or other loss of the thermal insulant or structural material upon which the insulant depends for its effectiveness in the longer duration of this fire compared with that for Type B(U) and Type B(M) packages.

736.6. For further material see also para. 728.

737.1. In determining the conditions for the test, the goal was to define the combination of specified velocities normal to an unyielding target that will produce damage conditions to the specimen equivalent to those that might be expected from aircraft impacts at actual speeds onto real surfaces and at randomly occurring angles. Probabilistic distributions of the variable in accidents were considered, as well as the package orientation that is most vulnerable to damage.

737.2. Data on which to base accident analyses have been obtained from reports on the particulars of accidents that are filed by officials on the scene and those involved in subsequent investigations. Some of the data are based on actual measurements. Other data are derived by analysis of data and inferences based on a notion of how the accident probably progressed. Each accident report must be evaluated and converted to some basic characteristics, such as impact speed, character of the impacted mass, impact angle, nature of the impact surface, and the like. It is frequently necessary to obtain other accounts of an accident to cross-check information.

737.3. Basic data that might come from an accident report are useful, but do not include the effects of the character of the accident or the environment likely to have been experienced by the cargo involved. For instance, the damage to conveyance and the cargo could be very different if the conveyance impacted a small car, a soft bank, or a bridge abutment. To account for this effect, an analysis is performed to translate the actual impact velocity into an effective head-on impact velocity onto a surface that itself absorbs none of the energy of the impact. Such a surface is called an unyielding surface. Thus, all of the available energy ends up in deformation of the conveyance and the cargo of radioactive material packages. Since the analyst is interested in the cargo, it is normal to assume that the conveyance absorbs no energy; this assumption leads to conservative analysis.

737.4. With the assumption that the cargo impacts at the speed of the conveyance, an analytic translation to effective impact speed onto an unyielding surface will result in an effective impact speed that is lower and depends on the relative strength of the cargo compared to that of the actual impacting surface. For a 'hard' package and 'soft' target (for example, a spent fuel flask on water) the ratio of actual to effective velocity might range from 7 to 9. For similar hardness in package and surface, the ratio might be 2 or more. For concrete roadways and runways, the velocity ratio could range from 1.1 to 1.4. There are very few surfaces for which the ratio would be 1 [37].

737.5. Conversion of the basic accident report data to effective impact velocity is performed to normalize the accident environment for impact in a standard format that

removes much of the variability of the accident scenarios but, at the same time, preserves the stress on the cargo. Repeating this process for all relevant aircraft accidents produces a statistical basis for choosing an effective impact speed onto a rigid target [42–44].

737.6. Package designs that release no more than an A_2 quantity of radioactive material in a week when subjected to performance testing might be assumed to release their total contents at just slightly more severe conditions. However, such eventualities are not expected. Rather it is expected that a package designed to meet the Regulations will limit releases to accepted levels until the accident environments are well beyond those provided in the performance standards and then will only gradually allow increased release as accident environments greatly exceed the performance test levels; that is, packages should ‘fail gracefully’. This behaviour results from:

- (1) The factors of safety incorporated into package designs;
- (2) The capability of materials used in the package for a specific purpose, such as shielding, to mitigate loads when that capability is not explicitly considered in the design analysis;
- (3) Material capability to resist loads well beyond the elastic limit; and
- (4) Reluctance of designers to use and/or competent authorities to approve materials that have abrupt failure thresholds as a result of melting or fracturing in environments likely to occur in transport.

737.7. While all of these features of good package design are expected to provide the desired property of graceful failure, it is also true that there are only very limited data available on packages tested to failure to see how release increases with severity of the accident environment. Limited test data and analyses that have been performed support the concept of graceful failure [44–46].

737.8. The impact velocity for the test was derived from frequency distribution cumulative probability studies [37, 47–49]. Most accident environment analyses reveal that, as the severity of the impact environment increases, the number of events with that severity increases rapidly to a peak and then falls to zero as the severity approaches a physical limit, such as the top speed limitations of the conveyance. Plotting these data as a cumulative curve, that is, a percentage of events with severity less than a given value, gives a curve that rises quickly at first and then rises very slowly after the ‘knee’ of the curve is reached. When the data are plotted in a format that shows the probability of exceeding a given impact velocity, the scarcity of severe accidents manifests itself as a distinct bend or ‘knee’ in the curve. This area of the curve is of interest because it indicates where increased levels of protection built into

a package begin to have less effect on the probability of failure. Furthermore, the area to the left of the 'knee' covers approximately 95% of all accidents. The knee of the curve occurs at about 90 m/s. This value was chosen for the normal component for the impact test.

737.9. Requiring a package design to protect against a normal velocity much higher than the value at the knee generally means a more massive, more complicated and more expensive package design that achieves little increase in the protection afforded the public. In addition, a design that survives impact at the velocity at the knee will survive many accidents at speeds above the knee because of the conservatism in package design, conservatism in the analysis of accident data and the conversion of those data into effective impact speed onto an unyielding target. In other words, complete catastrophic failure of containment is not likely to occur even at the extreme portion of the curve.

737.10. The need for a package terminal velocity test was discussed in context of the impact test, but it is expected that the impact of a package at terminal velocity is taken into account by the 90 m/s impact test. The purpose of a terminal velocity condition would be to demonstrate that the package design would provide protection in the event that the package is ejected overboard from the aircraft. This situation could arise as a result of mid-air collision or in-flight airframe failure. Nevertheless, it is noted that Type C package requirements already include an impact test on an unyielding surface at a velocity of 90 m/s. This test provides a rigorous demonstration of package integrity for cargo overboard scenarios.

737.11. While the free fall package velocity may exceed 90 m/s, it is unlikely that the impact surface would be as hard as the unyielding surface specified in the impact test. It is also noted that the probability of aircraft accidents of any type is low and that the percentage of such accidents that involve mid-air collisions or in-flight airframe failures is very low. If such an accident were to occur to an aircraft carrying a Type C package, damage to the package could be mitigated if the package remained attached to airframe wreckage during descent, which would tend to reduce the package impact velocity.

737.12. Subjecting a package to an impact on an unyielding surface with an impact speed of 90 m/s is a difficult test to perform well. This impact speed corresponds to a free drop through a height of about 420 m, without taking into consideration air resistance. This means that guide wires will generally be needed to assure that the package impacts in the desired spot and with the correct orientation. Guided free fall will mean that friction must be accounted for in an even greater release height to assure the speed at impact is correct. Techniques that utilize additional sources of

energy to achieve speed and orientation reliability may also be used. These techniques include rocket sleds and cable pulldown facilities.

737.13. Additionally, useful information is provided in paras 701.1–701.24 and 727.6–727.17.

737.14. For a package containing fissile material in quantities not excepted by para. 672, the term ‘maximum damage’ should be taken as the damaged condition that will result in the maximum neutron multiplication factor.

REFERENCES TO SECTION VII

- [1] INTERNATIONAL ORGANIZATION FOR STANDARDIZATION, Sealed Radioactive Sources — Classification, Rep. ISO 2919-1980(E), ISO, Geneva (1980).
- [2] INTERNATIONAL ORGANIZATION FOR STANDARDIZATION, Radiation Protection — Sealed Radioactive Sources — Leakage Test Methods, Rep. ISO 9978, ISO, Geneva (1992).
- [3] AMERICAN NATIONAL STANDARDS INSTITUTE, American National Standard for Leakage Tests on Packages for Shipment of Radioactive Material, ANSI N14.5-1977, ANSI, New York (1977).
- [4] INTERNATIONAL ORGANIZATION FOR STANDARDIZATION, Safe Transport of Radioactive Material — Leakage Testing of Packages, Rep. ISO 12807:1996(E), first edition 1996.09.15, ISO, Geneva (1996).
- [5] INTERNATIONAL ORGANIZATION FOR STANDARDIZATION, Radioactive Materials — Packaging — Test for Contents Leakage and Radiation Leakage, Rep. ISO 2855-1976(E), ISO, Geneva (1976).
- [6] DROSTE, B., et al., “Evaluation of safety of casks impacting different types of targets”, Packaging and Transportation of Radioactive Materials, PATRAM 98 (Proc. Symp. Paris, 1998), Institut de Protection et de Surêté Nucléaire (IPSN), Paris (1998).
- [7] INTERNATIONAL ATOMIC ENERGY AGENCY, Transport Packaging for Radioactive Materials (Proc. Sem. Vienna, 1976), IAEA, Vienna (1976).
- [8] Packaging and Transportation of Radioactive Materials (PATRAM), Proc. Symp. Albuquerque, 1965: Sandia Laboratories, Albuquerque, NM (1965); Gatlinburg, 1968: United States Atomic Energy Commission, Oak Ridge, TN (1968); Richland, 1971: United States Atomic Energy Commission, Oak Ridge, TN (1971); Miami Beach, 1974: Union Carbide Corp., Nuclear Div., Oak Ridge, TN (1975); Las Vegas, 1978: Sandia National Laboratories, Albuquerque, NM (1978); Berlin (West), 1980: Bundesanstalt für Materialprüfung, Berlin (1980); New Orleans, 1983: Oak Ridge National Laboratory, Oak Ridge, TN (1983); Davos, 1986: International Atomic Energy Agency, Vienna (1987).
- [9] INTERNATIONAL ORGANIZATION FOR STANDARDIZATION, Packaging of Uranium Hexafluoride (UF₆) for Transport, Rep. ISO 7195:1993(E), ISO, Geneva (1993).

- [10] INTERNATIONAL ATOMIC ENERGY AGENCY, Directory of Transport Packaging Test Facilities, IAEA-TECDOC-295, IAEA, Vienna (1983).
- [11] Directory of Test Facilities for Radioactive Materials Transport Packages, Special Issue, Int. J. Radioact. Mater. Transp. 2 4–5 (1991).
- [12] UNITED NATIONS, Recommendations on the Transport of Dangerous Goods, 9th Revised Edition, ST/SG/AC.10/1/Rev.9, UN, New York and Geneva (1995).
- [13] CLARKE, R.K., FOLEY, J.T., HARTMAN, W.F., LARSON, D.W., Severities of Transportation Accidents, Rep. SLA-74-0001, Sandia National Laboratories, Albuquerque, NM (1976).
- [14] DENNIS, A.W., FOLEY, J.T., HARTMAN, W.F., LARSON, D.W., Severities of Transportation Accidents Involving Large Packages, Rep. SLA-77-0001, Sandia National Laboratories, Albuquerque, NM (1978).
- [15] McCLURE, J.D., An Analysis of the Qualification Criteria for Small Radioactive Material Shipping Packages, Rep. SAND-76-0708, Sandia National Laboratories, Albuquerque, NM (1977).
- [16] McCLURE, J.D., et al., “Relative response of Type B packagings to regulatory and other impact test environments”, Packaging and Transportation of Radioactive Materials, PATRAM 80 (Proc. Symp. Berlin, 1980), Bundesanstalt für Materialprüfung, Berlin (1980).
- [17] BLYTHE, R.A., MILES, J.C., HOLT, P.J., “A study of the influence of target material on impact damage”, Packaging and Transportation of Radioactive Materials, PATRAM 83 (Proc. Symp. New Orleans, 1983), Oak Ridge National Laboratory, Oak Ridge, TN (1983).
- [18] GABLIN, K.A., “Non-shielded transport package impact response to unyielding and semi-yielding surfaces”, *ibid.*
- [19] HÜBNER, H.W., MASSLOWSKI, J.P., “Interactions between crush conditions and fire resistance for Type B packages less than 500 kg”, *ibid.*
- [20] DIGGS, J.M., LEISHER, W.B., POPE, R.B., TRUJILLO, A.A., "Testing to define the sensitivity of small Type B packagings to the proposed IAEA crush test requirement", *ibid.*
- [21] CHEVALIER, G., GILLES, P., POUARD, P., “Justification and advantages of crushing tests compared with fall tests and the modification of existing regulations”, *ibid.*
- [22] COLTON, J.D., ROMANDER, C.M., Potential Crush Loading of Radioactive Material Packages in Highway, Rail and Marine Accidents, Rep. NUREG/CR-1588, SRI International, Menlo Park, CA (1980).
- [23] OAK RIDGE NATIONAL LABORATORY, Cask Designers Guide, Rep. ORNL–NSIC–68, UC-80, Oak Ridge National Laboratory, Oak Ridge, TN (1976).
- [24] DIGGS, J.M., POPE, R.B., TRUJILLO, A.A., UNCAPHER, W.L., Crush Testing of Small Type B Packagings, Rep. SAND-83-1145, Sandia National Laboratories, Albuquerque, NM (1985).
- [25] McCLURE, J.D., The Probability of Spent Fuel Transportation Accidents, Rep. SAND-80-1721, Sandia National Laboratories, Albuquerque, NM (1981).
- [26] WILMOT, E.L., McCLURE, J.D., LUNA, R.E., Report on a Workshop on Transportation Accident Scenarios Involving Spent Fuel, Rep. SAND-80-2012, Sandia National Laboratories, Albuquerque, NM (1981).

- [27] POPE, R.B., YOSHIMURA, H.R., HAMANN, J.E., KLEIN, D.E., An Assessment of Accident Thermal Testing and Analysis Procedures for a RAM Shipping Package, ASME Paper 80-HT-38, American Society for Testing and Materials, Philadelphia, PA (1980).
- [28] JEFFERSON, R.M., McCLURE, J.D., "Regulation versus reality", Packaging and Transportation of Radioactive Materials, PATRAM 83 (Proc. Symp. New Orleans, 1983), Oak Ridge National Laboratory, Oak Ridge, TN (1983).
- [29] FRY, C.J., "The use of CFD for modelling pool fires", Packaging and Transportation of Radioactive Materials, PATRAM 92 (Proc. Symp. Yokohama City, 1992), Science & Technology Agency, Tokyo (1992).
- [30] FRY, C. J., "An experimental examination of the IAEA fire test parameters", *ibid*.
- [31] WIESER, G., DROSTE. B., "Thermal test requirements and their verification by different test methods", *ibid*.
- [32] BAINBRIDGE, B.L., KELTNER, N.R., Heat transfer to large objects in large pool fires, *J. Hazard. Mater.* **20** (1988) 21–40.
- [33] KELTNER, N.R., MOYA, J.L., Defining the thermal environment in fire tests, *Fire and Materials* **14** (1989) 133–138.
- [34] BURGESS, M., FRY, C.J., Fire testing for package approval, *Int. J. Radioact. Mater. Transp.* **1** (1990).
- [35] McCAFFERY, B.J., Purely Buoyant Diffusion Flames — Some Experimental Results, Rep. PB80-112 113, US National Bureau of Standards, Washington, DC (1979).
- [36] McADAMS, W.H., Heat Transmission, McGraw-Hill, New York (1954).
- [37] INTERNATIONAL ATOMIC ENERGY AGENCY, The Air Transport of Radioactive Material in Large Quantities or with High Activity, IAEA-TECDOC-702, IAEA, Vienna (1993).
- [38] McSWEENEY, T.I., JOHNSON, J.F., An Assessment of the Risk of Transporting Plutonium Dioxide by Cargo Aircraft", BNWL-2-30 UC-71, Battelle Pacific Northwest Laboratory, Richland, WA (1977).
- [39] McCLURE, J.D., VON RIESEMANN, W.A., Crush Environment for Small Containers Carried on US Commercial Jet Aircraft, Report letter, Sandia National Laboratories, Albuquerque, NM (1976).
- [40] BROWN, M.L., et al., Specification of Test Criteria for Containers to be Used in the Air Transport of Plutonium, Safety & Reliability Directorate, UKAEA, London (1980).
- [41] HARTMAN, W.F., et al., "An analysis of the engine fragment threat and the crush environment for small packages carried on US commercial jet aircraft", Packaging and Transport of Radioactive Materials, PATRAM 78 (Proc. Symp. New Orleans, 1978), Sandia National Laboratories, Albuquerque, NM (1978).
- [42] UNITED STATES NUCLEAR REGULATORY COMMISSION, Qualification Criteria to Certify a Package for Air Transport of Plutonium, Rep. NUREG/0360, USNRC, Washington, DC (1978).
- [43] WILKINSON, H.L., "A study of severe aircraft crash environments with particular reference to the carriage of radioactive material", SARSS 89 (Proc. Symp. Bath, UK, 1989), Elsevier, Amsterdam and New York (1989).
- [44] BONSON, L.L., Final Report on Special Impact Tests of Plutonium Shipping Containers: Description of Test Results, Rep. SAND-76-0437, Sandia National Laboratories, Albuquerque, NM (1977).

- [45] McWHIRTER, M., et al., Final Report on Special Tests of Plutonium Oxide Shipping Containers to FAA Flight Recorder Survivability Standards, Rep. SAND-75-0446, Sandia National Laboratories, Albuquerque, NM (1975).
- [46] STRAVASNIK, L.F., Special Tests for Plutonium Shipping Containers 6M, SP5795 and L-10, Development Rep. SC-DR-72059, Sandia National Laboratories, Albuquerque, NM (1972).
- [47] BROWN, M.L., EDWARDS, A.R., HALL, S.F., et al., Specification of Test Criteria for Containers to be Used in the Air Transport of Plutonium, Rep. EUR 6994 EN, CEC, Brussels and Luxembourg (1980).
- [48] McCLURE, J.D., LUNA, R.E., "An Analysis of Severe Air Transport Accidents", Packaging and Transportation of Radioactive Material, PATRAM 89 (Proc. Symp. Washington, DC, 1989), Oak Ridge National Laboratory, Oak Ridge, TN (1989).
- [49] DEVILLERS, C., et al., "A Regulatory Approach to the Safe Transport of Plutonium by Air", *ibid.*

Section VIII

APPROVAL AND ADMINISTRATIVE REQUIREMENTS

GENERAL ASPECTS

801.1. The Regulations distinguish between cases where the transport can be made without competent authority package design approval and cases where some kind of approval is required. In both cases the Regulations place primary responsibility for compliance on the consignor and the carrier. The consignor should be able to provide documentation in order to demonstrate to the competent authority, e.g. by calculations or by test reports, that the package design fulfils the requirements of the Regulations.

801.2. The 'relevant competent authority' may also include competent authorities of countries en route.

802.1. See paras 204.1–204.4 and 205.1.

802.2. In the case where competent authority approval is required, an independent assessment by the competent authority should be undertaken, as appropriate, in respect of: special form or low dispersible radioactive material; packages containing 0.1 kg or more of UF_6 ; packages containing fissile materials; Type B(U) and Type B(M) packages; Type C packages; special arrangements; certain shipments; radiation protection programmes for special use vessels; and the calculation of unlisted A_1 and A_2 values, unlisted activity concentrations for exempt material and unlisted activity limits for exempt consignments.

802.3. Regarding the requirement for competent authority approval for packages designed to contain fissile material, it is noted that para. 672 excludes certain packages from those requirements that apply specifically to fissile material. However, all relevant requirements that apply to the radioactive, non-fissile properties of the package contents still apply.

802.4. The relationship between the competent authority and the applicant has to be clearly understood. It is the applicant's responsibility to 'make the case' to demonstrate compliance with the applicable requirements. The competent authority's responsibility is to judge whether or not the information submitted adequately demonstrates such compliance. The competent authority should be free to check statements, calculations and assessments made by the applicant, even, if necessary, by performance of independent calculations or tests. However, it should not 'make the case' for the applicant, because this would put it in the difficult position of being both 'advocate' and 'judge'.

Nevertheless, this does not prohibit it from providing informal advice to the applicant, without commitment, as to what is likely to be an acceptable way of demonstrating compliance.

802.5. Further details of the role of the competent authority can be found in regulations issued nationally or by the international transport organizations.

802.6. The applicant should contact the competent authority during the preliminary design stage to discuss the implementation of the relevant design principles and to establish both the approval procedure and the actions which should be carried out.

802.7. Experience has shown that many applicants make their first submission in terms of a specific and immediate need which is rather narrow in scope, and then later make several requests for amendments to the approval certificate as they attempt to expand its scope to use the packaging for other types of material and/or shipment. Whenever possible, applicants should be encouraged to make their first submission a general case, which will anticipate and cover their future needs. This will make the 'application–approval' system operate more efficiently. Additionally, in some cases, it is mutually advantageous for the prospective applicant and the competent authority to discuss a proposed application in outline before it is formally submitted in detail.

802.8. Further guidance is given in Annex II of IAEA Safety Series No. 112 [1].

APPROVAL OF SPECIAL FORM RADIOACTIVE MATERIAL AND LOW DISPERSIBLE RADIOACTIVE MATERIAL

803.1. The design for special radioactive material is required to receive unilateral competent authority approval prior to transport, while the design for low dispersible material requires multilateral approval. Paragraph 803 specifies the minimum information to be included in an application for approval.

804.1. Detailed advice on identification marks is given in paras 828.1–828.3.

APPROVAL OF PACKAGE DESIGNS

Approval of package designs to contain uranium hexafluoride

805.1. The approval of packages designed to carry non-fissile or fissile excepted uranium hexafluoride in quantities greater than 0.1 kg is a new requirement, introduced

in the 1996 edition of the Regulations. Because this edition of the Regulations introduced specific design and testing requirements, it became necessary to require certification. Thus, a new category of package identification was introduced (see para. 828), and certification of package designs requiring multilateral approval will be required three years earlier than will certification of unilaterally approved package designs. This step was taken to ensure that those designs which do not satisfy all of the new requirements are addressed early in the certification process.

Approval of Type B(M) package designs

810.1. Information given by the applicant with regard to paras 810(a) and (b) will enable the competent authority to assess the implications of the lack of conformance of the Type B(M) design with Type B(U) requirements as well as to determine whether the proposed supplementary controls are sufficient to provide a comparable level of safety. The purpose of supplementary controls is to compensate for the safety measures that could not be incorporated into the design. Through the mechanism of multilateral approval the design of a Type B(M) package is independently assessed by competent authorities in all countries through or into which such packages are transported.

810.2. Special attention should be given to stating which of the Type B(U) requirements of paras 637, 653, 654 and 657–664 are not met by the package design. Proposed supplementary operational controls or restrictions (i.e. other than those already required by the Regulations) which are to be applied to compensate for failure to meet the above mentioned requirements should be fully identified, described and justified. The maximum and minimum ambient conditions of temperature and insulation which are expected during transport should be identified and justified with reference to the regions or countries of use and appropriate meteorological data. See also paras 665.1 and 665.2.

810.3. Where intermittent venting of Type B(M) packages is required, a complete description of the procedures and controls should be submitted to the competent authority for approval. Further advice may be found in paras 666.1–666.6.

Approval of package designs to contain fissile material

812.1. Multilateral approval is required for all package designs for fissile material (IF, AF, B(U)F, B(M)F and CF) primarily because of the nature of the criticality hazard and the importance of maintaining subcriticality at all times in transport. Moreover, the regulatory provisions for package design for fissile materials allow complete freedom as to the methods, usually computational, by which compliance is

demonstrated. It is therefore necessary that competent authorities independently assess and approve all package designs for fissile materials.

812.2. A package design for fissile material is required to meet the requirements regarding both the radioactive and fissile properties of the package contents. Regarding the radioactive properties, a package is classified in accordance with the definition of package in para. 230. As applicable, a package design approval based on the radioactive, non-fissile properties of the package contents is required. In addition to such approval, a design approval is required relating to the fissile properties of the package contents. See para. 672 for exceptions regarding requirements on package design approval for fissile material.

813.1. The information provided to the competent authority with the application for approval is required to detail the demonstration of compliance with each requirement of paras 671 and 673–682. In particular, the information should include the items specifically quoted in the competent authority approval certificate as detailed in para. 833(m). The inclusion of appropriate information on any experiments, calculations or reasoned arguments used to demonstrate the subcriticality of the individual package or of arrays of packages is acceptable. Sufficient information should be submitted to permit the competent authority to verify compliance of the package with these regulations.

TRANSITIONAL ARRANGEMENTS

Packages not requiring competent authority approval of design under the 1985 and 1985 (as amended 1990) edition of these Regulations

815.1. Following the adoption of the 1985 edition of the Regulations, packages not requiring approval of design by competent authority based on the 1973 edition of the Regulations and the 1973 (as amended) edition of the Regulations could no longer be used. Continued operational use of such packages required either that the design be reviewed according to the requirements of the 1985 edition of the Regulations, or that shipments be reviewed and approved by the competent authority as special arrangements, although this was not explicitly stated in the Regulations.

815.2. Paragraph 815 was introduced into the 1996 edition of the Regulations to allow such existing packagings to continue in use for a limited and defined period of time following publication, during which the designs might be reviewed, and if necessary modified, to ensure they meet the requirements of the 1996 edition of the Regulations in full. Where such review and/or modification proves impractical, the

transition period is intended to allow time for package designs to be phased out and new package designs meeting the requirements of the 1996 edition of the Regulations to be phased in. Packages prepared in accordance with the 1985 or 1985 (as amended 1990) editions of the Regulations are sometimes stored for many years prior to further shipment. This may be particularly applicable in the case of Industrial or Type A packages containing radioactive waste and awaiting shipment to intermediate or final storage repositories. Paragraph 815 allows such packages, prepared during a defined period of time and when properly maintained, to be transported in the future on the basis of compliance with the 1985 editions of the Regulations.

815.3. Paragraph 815 emphasizes the requirement to apply quality assurance measures, according to the 1996 edition of the Regulations, to ensure that only such packages remain in use which continue to meet the original design intent or regulatory requirements. This can best be achieved by ensuring that the latest quality assurance measures are applied to post-manufacturing activities such as servicing, maintenance, modification and use of such packages.

815.4. The reference to Section IV of the 1996 Regulations is included to ensure that only the most recent radiological data (as reflected in A_1 and A_2 values) are used to determine package content and other related limits. It should be noted that the scope of the transitional arrangements of the Regulations only extends to the requirements for certain packagings and packages. In all other aspects, e.g. concerning general provisions, the requirements and controls for transport including consignment and conveyance limits, and approval and administrative requirements, the provisions of the 1996 edition of the Regulations apply.

815.5. Any revision to the original package design, or increase in contained activity, or addition of other types of radioactive material, which would significantly and detrimentally affect safety, as determined by the package owner in consultation with the package designer, will require the design to be reassessed according to the 1996 edition of the Regulations. This could include items such as an increase in the mass of the contents, changes to the closure, changes to any impact limiters, changes to the thermal protection and shielding, and changes in the form of the contents.

Packages approved under the 1973, 1973 (as amended), 1985 and 1985 (as amended 1990) editions of these Regulations

816.1. Following the adoption of the 1985 edition of the Regulations, packages requiring approval of design by competent authority (Type B, Type B(U), Type B(M) packages and package designs for fissile material) based on the 1967 edition, the 1973 edition and the 1973 (as amended) edition of the Regulations were permitted to

continue in use, subject to certain limitations on new manufacture, additional requirements to mark such packages with serial numbers and multilateral approval of all such designs. This provision, known colloquially as ‘grandfathering’, was newly introduced into the 1985 edition of the Regulations to ease the transition to those Regulations. This allowed packages, provided they were properly maintained and continued to meet their original design intent, to continue in use to the end of their useful design lives. It also provided for a period of time following publication, during which the designs could be reviewed, and if necessary modified, to ensure packages met the requirements of the 1985 edition of the Regulations in full. Where such review and/or modification proved impractical, the transition period allowed time for packages to be phased out and new designs meeting the requirements of the 1985 edition of the Regulations to be phased in.

816.2. The references to Section IV and para. 680 of the 1996 edition of the Regulations are included to ensure that only the most recent radiological data (as reflected in the A_1 and A_2 values) and requirements for fissile material transported by air may be used to determine package content and other related limits. It should be noted that the scope of the transitional arrangements of the regulations only extends to the requirements for certain packagings and packages. In all other aspects, e.g. concerning general provisions, the requirements and controls for transport including consignment and conveyance limits, and approval and administrative requirements, the provisions of the 1996 edition of the Regulations apply.

816.3. In the process of developing the 1996 edition of the Regulations, it was determined that there was no need for an immediate change of the Regulations following their adoption, but that changes aiming at a long term improvement of safety in transport were justified. Therefore it was also decided to accept continued operational use of certain packages designed and approved under the 1973 edition of the Regulations. The continued use of existing packagings with a 1967 edition based package design approval was considered to be no longer necessary or justified.

816.4. The continued use of approved packages meeting the requirements of the 1973 or 1973 (as amended) edition of the Regulations is subject to multilateral approval from the date the 1996 edition of the Regulations enters into force, in order to permit the competent authorities to establish a framework within which continued use may be approved. Additionally, no new manufacture of packagings to such designs is permitted to commence. This transition period has been determined on the basis of an assessment of the time needed to incorporate the 1996 edition of the Regulations into national and international regulations.

816.5. See para. 538.2.

816.6. For any revision to the original package design, or increase in activity of the contained materials, or addition of other types of radioactive material, which would significantly and detrimentally affect safety, as determined by the competent authority, the design should be reassessed and approved according to the 1996 edition of the Regulations. Such factors could include an increase in the mass of the contents, changes to the closure, changes to any impact limiters, changes to the thermal protection or shielding, and changes in the form of the contents.

816.7. When applying para. 816, the original competent authority identification mark and design type codes, assigned by the original competent authority of design, should be retained both on the packages and on the competent authority certificates of design approval, notwithstanding that these packages become subject to multilateral approval of design. This means that packages originally designated Type B(U) or Type B(U)F under the 1973 edition of the Regulations should not be redesignated Type B(M) or Type B(M)F, nor should they be redesignated Type B(M)-96 or Type B(M)F-96, when used under the provisions of para. 816. This is to ensure that such packages can be clearly identified as packages ‘grandfathered’ under the provisions of para. 816, having been originally approved under the 1973 edition of the Regulations.

817.1. See paras 816.1 and 816.2.

817.2. In the process of developing the 1996 edition of the Regulations, it was determined that there was no need for an immediate change of the Regulations following their adoption, but that changes aiming at long term improvement of safety in transport were justified. Therefore it was also decided to accept continued operational use of certain packages designed and approved under the 1985 edition of the Regulations.

817.3. The continued use of approved packages meeting the 1985 or 1985 (as amended 1990) edition of the Regulations is subject to multilateral approval after 31 December 2003, in order to permit the competent authorities to establish a framework within which continued use may be approved. Additionally, no new manufacture of such packagings is permitted to commence beyond 31 December 2006. These transition periods have been determined on the basis of an assessment of the time needed to incorporate the 1996 edition of the Regulations into national and international regulations.

817.4. When applying para. 817, the original competent authority identification mark and design type codes, assigned by the original competent authority of design, should be retained both on the packages and on the competent authority certificates of design approval, notwithstanding that these packages become subject to multilateral

approval of design beyond 31 December 2003. This means that packages originally designated Type B(U)-85 or Type B(U)F-85 under the 1985 edition of the Regulations should not be redesignated Type B(M)-85 or Type B(M)F-85, nor should they be redesignated Type B(M)-96 or Type B(M)F-96, when used under the provisions of para. 817. This is to ensure that such packages can be clearly identified as packages 'grandfathered' under the provisions of para. 817, having been originally approved under the 1985 edition of the Regulations.

Special form radioactive material approved under the 1973, 1973 (as amended), 1985 and 1985 (as amended 1990) editions of these Regulations

818.1. Paragraph 818 introduces transitional arrangements for special form radioactive material, the design of which is also subject to competent authority approval. It emphasizes the need to apply quality assurance measures according to the 1996 edition of the Regulations to ensure that such special form radioactive material remains in use only where it continues to meet the original design intent or regulatory requirements. This can best be achieved by ensuring that the latest quality assurance measures are applied to post-manufacturing activities such as servicing, maintenance, modification and use of such special form material. It should be noted that the scope of the transitional arrangements of the Regulations only extends to the requirements for certain special form radioactive materials. In all other aspects, e.g. concerning general provisions, the requirements and controls for transport including consignment and conveyance limits, and approval and administrative requirements, the provisions of the 1996 edition of the Regulations apply.

818.2. In the process of developing the 1996 edition of the Regulations it was determined that there was no need for an immediate change of the Regulations following their adoption, but that changes aiming at a long term improvement of safety in transport were justified. Therefore it was also decided to accept continued operational use of special form radioactive material designed and approved under the 1973 or 1985 editions of the Regulations. However, no new manufacture of such special form radioactive material is permitted to commence beyond 31 December 2003. The continued use of existing special form radioactive material with a 1967 edition based design approval was considered to be no longer necessary or justified.

NOTIFICATION AND REGISTRATION OF SERIAL NUMBERS

819.1. The competent authority should monitor specific facets associated with the design, manufacture and use of packagings within its compliance assurance programme (see para. 311). To verify adequate performance, the serial number of all packagings

manufactured to a design approved by a competent authority is required to be made available to that competent authority. The competent authorities should maintain a register of the serial numbers.

819.2. Packagings manufactured to a package design approved for continued use under the ‘grandfather’ provisions in paras 816 and 817 are also to be assigned a serial number. The serial number, and competent authority knowledge of this serial number, is essential in that the number establishes the means to positively identify which single individual packagings are subject to the respective ‘grandfather’ provision.

819.3. The packaging serial number should uniquely identify each packaging manufactured. The appropriate competent authority is to be informed of the serial number. The term ‘appropriate’ has a broad interpretation and could pertain to any of the following:

- the country where the package design originated;
- the country where the packaging was manufactured; or
- the country or countries where the package is used.

In the case of packagings manufactured to a package design approved for continued use under paras 816 and 817, all competent authorities involved in the multilateral approval process should receive information on packaging serial numbers.

APPROVAL OF SHIPMENTS

820.1. Where shipment approvals are required, such approvals must cover the entire movement of a consignment from origin to destination. If the consignment crosses a national border the shipment approval must be multilateral, i.e. the shipment must be approved by the competent authority of the country in which the shipment originates and by the competent authorities of all the countries through or into which the consignment is transported. The purpose of the requirement of multilateral approval is to enable the competent authorities concerned to judge the need for any special controls to be applied during transport.

820.2. Each requirement in para. 820 should be applied separately. For example, a consignment of a vented Type B(M) package containing fissile material may need a shipment approval according to both paras 820(a) and 820(c).

820.3. The need to apply para. 820 is governed by the actual contents of the package to be transported. For example, when a Type B(M) packaging, for which the package

design approval certificate gives the permitted contents as Co-60 limited to 1600 TBq, is used for shipment of only 400 TBq Co-60, no shipment approval is required since 400 TBq is less than 1000 TBq.

821.1. According to paras 802(a)(iv)–(vi) package design approvals are required for defined package designs. Some of those packages may be transported without additional shipment approval, while for others such approval is required (see para. 820). In some cases, an additional shipment approval is required because operational or other controls may be necessary and those controls may be dependent on the actual package contents. In situations where the need for controls during shipment can be determined at the design review and approval stage, the need to review single shipments does not exist. In such cases the package design and shipment approvals may be combined into one approval document.

821.2. The Regulations conceptually differentiate between design approvals and shipment approvals. A shipment approval may be incorporated into the corresponding design approval certificate, and if this is done care should be exercised to clearly define the dual nature of the approval certificate and to apply the proper type codes. For type codes see para. 828.

APPROVAL OF SHIPMENTS UNDER SPECIAL ARRANGEMENT

824.1. Although an approval of a shipment under special arrangement will require consideration of both the shipment procedures and the package design, the approval is conceptually a shipment approval. Further guidance may be found in paras 312.1–312.4.

825.1. The level of safety necessary in special arrangement shipments is normally achieved by imposing operational controls to compensate for any non-conformances in the packaging or the shipping procedures. Some of the operational controls which may be effectively employed are as follows:

- (a) Exclusive use of vehicle (see para. 221).
- (b) Escort of shipment. The escort is normally a radiation protection specialist who is equipped with radiation monitoring instruments and is familiar with emergency procedures enabling him, in the event of an accident or other abnormal event, to identify quickly any radiation and contamination hazards present and to provide appropriate advice to the civil authorities. For road transport the escort, whenever possible, should travel in a separate vehicle so as not to be incapacitated by the same accident. The escort should also be equipped with

stakes, ropes and signs to cordon off an accident area and with a fire extinguisher to control minor fires, and a communications system. If considered prudent, the radiation protection specialist could be accompanied by police and fire department escorts.

- (c) Routing of shipment may be controlled in order to select the potentially least hazardous routes and, if possible, to avoid areas of high population density and possible hazards, such as steep gradients and railway level crossings.
- (d) Timing of shipment may be controlled to avoid busy periods such as rush hours and weekend traffic peaks.
- (e) Shipments should be made directly, i.e. without stopover or transshipment, where possible.
- (f) Transport vehicle speeds may be limited, particularly if the impact resistance of the packaging is low and if the slower speed of the transport vehicle would not cause additional hazards (such as collisions involving faster moving vehicles).
- (g) Consideration should be given to notifying the emergency services (police and fire departments) in advance.
- (h) Emergency procedures (either ad hoc or standing) should exist for contingencies resulting from the shipment being involved in an accident.
- (i) Ancillary equipment such as package-to-vehicle tie-down or shock absorber systems and other protective devices or structures should be used, where necessary, as compensatory safety arrangements.

COMPETENT AUTHORITY APPROVAL CERTIFICATES

Competent authority identification marks

828.1. In applying and interpreting the type codes it is necessary to keep in mind that the code is based on the use of several indicators intended to quickly provide information on the type of package or shipment in question. The indicators provide information on package design characteristics (e.g. Type B(U), Type B(M) or Type C) or on the possible presence of fissile material in the package, and on other specific aspects of the approval certificate (e.g. for special arrangement, shipment, special form, low dispersible radioactive material, or non-fissile or fissile excepted uranium hexafluoride contents). Specifically, the appearance of, for example, B(U)F in the code does not necessarily imply the presence of fissile material in a particular package, only the possibility that it might be present.

828.2. It is essential that easy means are available, preferably in the identification mark, for determining under which edition of the Regulations the original package

design approval was issued. This will be achieved by adding the symbol ‘-96’ to the type code.

Example:

Edition of Regulations	Package design identification mark
1967	A/132/B
1973	A/132/B(U) or A/132/B(M)
1985	A/132/B(U)-85 or A/132/B(M)-85
1996	A/132/B(U)-96 or A/132/B(M)-96

828.3. This technique of adding a symbol may continue to be used provided later editions of the Regulations essentially maintain the present package type codes.

CONTENTS OF APPROVAL CERTIFICATES

Special form radioactive material and low dispersible radioactive material approval certificates

830.1. The purpose of the careful description of approval certificate content is twofold. It aims at providing assistance to competent authorities in designing their certificates and facilitates any checking of certificates because the information they contain is standardized.

830.2. The Regulations prescribe the basic information which must appear on certificates of approval and a competent authority identification mark system. Competent authorities are urged to follow these prescriptions as closely as possible to achieve international uniformity of certification. In addition to the applicable national regulations and the relevant international regulations, each certificate should make reference to the appropriate edition of the Regulations, because this is the internationally recognized and known standard. The international vehicle registration (VRI) code, which is used in competent authority identification marks, is given in Table IV.

Special arrangement approval certificates

831.1. As discussed in para. 418.1, during preparation of the certificate, care should be taken relative to the authorized quantity, type and form of the contents of each package because of the potential impact on criticality safety. Any special inspections or tests of the contents to confirm the characteristics of the contents prior to shipment should be specified in the certificate. This is of particular importance for any removable

TABLE IV. LIST OF VRI CODES BY COUNTRY

Country	VRI code	Country	VRI code
Afghanistan	AFG	France	F
Albania	AL	Gabon	GA
Algeria	DZ	Georgia	GE ^a
Angola	AO	Germany	D
Argentina	RA	Ghana	GH
Armenia	AM ^a	Greece	GR
Australia	AUS	Guatemala	GCA
Austria	A	Haiti	RH
Bangladesh	BD	Holy See	VA
Belarus	BEL	Hungary	H
Belgium	B	Iceland	IS
Benin	DY	India	IND
Bolivia	BOL	Indonesia	RI
Bosnia & Herzegovina	BIH	Iran, Islamic Republic of	IR
Brazil	BR	Iraq	IRQ
Bulgaria	BG	Ireland	IRL
Burkina Faso	BF	Israel	IL
Cambodia	K	Italy	I
Cameroon	CM	Jamaica	JA
Canada	CDN	Japan	J
Chile	RCH	Jordan	HKJ
China	CN	Kazakhstan	KK
Colombia	CO	Kenya	EAK
Costa Rica	CR	Korea, Democratic People's Republic of	KP
Côte d'Ivoire	CI	Korea, Republic of	ROK
Croatia	HR	Kuwait	KWT
Cuba	C	Latvia	LV
Cyprus	CY	Lebanon	RL
Czech Republic	CZ	Liberia	LB
Democratic Kampuchea ^b	KH ^a	Libyan Arab Jamahiriya	LAR
Democratic Republic of the Congo	RCB	Liechtenstein	FL
Denmark	DK	Lithuania	LT
Dominican Republic	DOM	Luxembourg	L
Ecuador	EC	Madagascar	RM
Egypt	ET	Malaysia	MAL
El Salvador	ES	Mali	RMM
Estonia	EW	Malta	M
Ethiopia	ETH	Marshall Islands	PC
Finland	FIN	Mauritius	MS

TABLE IV. (cont.)

Country	VRI code	Country	VRI code
Mexico	MEX	Slovenia	SLO
Monaco	MC	South Africa	ZA
Mongolia	MN	Spain	E
Morocco	MA	Sri Lanka	CL
Myanmar	BUR	Sudan	SUD
Namibia	SWA	Sweden	S
Netherlands	NL	Switzerland	CH
New Zealand	NZ	Syrian Arab Republic	SYR
Nicaragua	NIC	Thailand	T
Niger	RN	The Former Yugoslav Republic of Macedonia	MK
Nigeria	WAN	Tunisia	TN
Norway	N	Turkey	TR
Pakistan	PAK	Uganda	EA
Panama	PA	Ukraine	UA
Paraguay	PY	United Arab Emirates	SV
Peru	PE	United Kingdom	GB
Philippines	RP	United Republic of Tanzania	EAT
Poland	PL	United States of America	USA
Portugal	P	Uruguay	U
Qatar	QA	Uzbekistan	US
Republic of Moldova	MOL	Venezuela	YV
Romania	R	Vietnam	VN
Russian Federation	RU	Yemen	YE
Saudi Arabia	SA	Yugoslavia, Federal Republic of	YU
Senegal	SN	Zambia	Z
Sierra Leone	WAL	Zimbabwe	ZW
Singapore	SGP		
Slovakia	SK		

^a ISO Code where no VRI Code is available.

^b Cambodia was formerly known as Democratic Kampuchea.

neutron poison or other criticality control feature that will be loaded in the package prior to shipment (see paras 502.4 and 502.5). Where appropriate, the criteria which the measurement must satisfy should be specified or referenced in the approval certificate.

831.2. Any special loading arrangement of the packages that should be adhered to or avoided should be noted in the special arrangement certificate.

Shipment approval certificates

832.1. See para. 831.1.

832.2. With this edition of the Regulations, packages that contain fissile material are excepted from the requirements of paras 673–682 if certain package and consignment requirements are met (see para. 672(a)). If the packages in the consignment contain fissile material that is excepted based on the package limits, care should be taken to ensure that the consignment limit is not exceeded. This will mean that the consignor should be knowledgeable relative to the upper limit of the fissile material quantity in each package or assume that the upper limit (see para. 672(a)) is contained in each package.

Package design approval certificates

833.1. As discussed in para. 418.1, care should be taken relative to the authorized quantity, type and form of the contents of each package because of the potential impact on criticality safety. Any inspections or tests of the contents that may be needed to confirm the characteristics of contents prior to shipment should be specified in the certificate. Measurements that satisfy the requirements of para. 674(b) may need to be performed prior to loading and/or shipment if the package contains irradiated nuclear fuel. The criteria that the measurement must satisfy should be specified or referenced in the certificate for the package (see related advisory material of para. 502.8). Similarly, if special features are allowed to exclude water in-leakage, specific inspections and/or test procedures to ensure compliance should be stated (or referenced) in the certificate.

VALIDATION OF CERTIFICATES

834.1. The approval certificate of the competent authority of the country of origin is usually the first to be issued in the series of multilateral approval certificates. Competent authorities other than that of the country of origin have the option of either performing a separate safety assessment and evaluation or making use of the assessment already made by the original competent authority, thus limiting the scope and extent of their own assessment.

834.2. Subsequent approval certificates may take either of two forms. First, a competent authority in a subsequent country may endorse the original certificate, i.e. agree with and endorse the original certificate including any definition of controls incorporated in it. This is multilateral approval by validation of the original certificate.

An approval by validation will not require any additional competent authority's identification mark, either in terms of certificate identification or marking on packages. Second, a competent authority may issue an approval certificate which is associated with, but separate from, the original certificate in that this subsequent certificate would bear an identification mark other than that of the original identification mark. Furthermore, in this case packagings in use under such a multilateral approval have to be marked with the identification marks of both the original and the subsequent approval certificates (see para. 829(b)).

REFERENCE TO SECTION VIII

- [1] INTERNATIONAL ATOMIC ENERGY AGENCY, Compliance Assurance for the Safe Transport of Radioactive Material, Safety Series No. 112, IAEA, Vienna (1994).

Appendix I

THE Q SYSTEM FOR THE CALCULATION AND APPLICATION OF A₁ AND A₂ VALUES

INTRODUCTION

I.1. The development of the 'Q system' was performed by H.F. Macdonald and E.P. Goldfinch of the United Kingdom Central Electricity Generating Board through a Research Agreement with the International Atomic Energy Agency. The Q system defines the 'quantity' limits, in terms of the A₁ and A₂ values, of a radionuclide that is allowed in a Type A package. These limits are also used for several other purposes in the Regulations such as in specifying Type B package activity leakage limits, LSA and excepted package contents limits, and contents limits for special form (non-dispersible) and non-special form (dispersible) radioactive materials. The 'Q' in the term Q system stands for 'quantity'.

I.2. A summary report of the original Q system activity was published in 1986 as IAEA-TECDOC-375 entitled "International Studies on Certain Aspects of the Safe Transport of Radioactive Materials, 1980–1985" [I.1]. The Q system was further refined by a Special IAEA Working Group in 1982. This served as the basis of the A₁ and A₂ values in the 1985 edition of the Regulations. In addition, K. Eckerman of the Health and Safety Division, Oak Ridge National Laboratory, USA, undertook the verification of the Q values under the sponsorship of the US Department of Transportation, and K. Shaw of the National Radiological Protection Board, United Kingdom, provided through his organization the annual limit on intake (ALI) values for radionuclides not included in ICRP Publication 30 [I.2–I.7].

I.3. In anticipation of the publication of the 1996 edition of the Regulations, the latest ICRP recommendations and data in the form of coefficients for dose per unit intake (dose coefficients) [I.8] were incorporated into the Q system by L. Bologna (ANPA, Italy), K. Eckerman (ORNL, USA) and S. Hughes (NRPB, UK). Their results served as a basis for updating the A₁ and A₂ values. An essential part of this work entailed a re-examination of the dosimetric models used in the derivation of the Type A package contents limits. The re-examination of the earlier models in turn gave rise to the further development of the Q system, resulting in an improved method for the evaluation of the A₁ and A₂ values. The revised methods of determining A₁ and A₂ values and the results therefrom are reported in this Appendix. Much of the information and discussion contained in this Appendix is historic but its retention is considered to be essential for a full understanding of the advice given.

BACKGROUND

I.4. The various limits for the control of radioactive releases from transport packages prescribed in the Regulations are based upon the activity contents limits for Type A packages. Type A packages are intended to provide economical transport for large numbers of low activity consignments, while at the same time achieving a high level of safety. The contents limits are set so as to ensure that the radiological consequences of severe damage to a Type A package are not unacceptable and design approval by the competent authority is not required, except for packages containing fissile material.

I.5. Activities in excess of the Type A package limits are covered in the Regulations by the requirements for Type B packages, which do require competent authority approval. The design requirements for Type B packages are such as to reduce to a very low level the probability of significant radioactive release from such packages as a result of a severe accident.

I.6. Originally, radionuclides were classified into seven groups for transport purposes, each group having its Type A package contents limits for special form radioactive material and for material in all other forms. Special form radioactive material was defined as that which was non-dispersible when subject to specified tests. In the 1973 edition of the Regulations the group classification system was developed into the A_1/A_2 system, in which each nuclide has a Type A package contents limit, A_1 curies, when transported in special form and a limit, A_2 curies, when not in special form.

I.7. The dosimetric basis of the A_1/A_2 system relied upon a number of somewhat pragmatic assumptions. A whole body dose of 3 rem (30 mSv) was used in the derivation of A_1 , although in calculating A_1 values the exposure was limited to 3 R at a distance of 3 m in a period of 3 h. Also, an intake of $10^{-6} A_2$, leading to half the ALI for a radiation worker, was assumed in the derivation of A_2 as a result of a 'median' accident. The median accident was defined arbitrarily as one which leads to complete loss of shielding and to a release of 10^{-3} of the package contents in such a manner that 10^{-3} of this released material was subsequently taken in by a bystander. The Q system described here includes consideration of a broader range of specific exposure pathways than the earlier A_1/A_2 system, but the same assumptions as used in the original Q system within the 1985 edition of the Regulations. Many of the assumptions made are similar to those stated, or implied, in the 1973 edition of the Regulations, but in situations involving the intake of radioactive material, use is made of new data and concepts recently recommended by the ICRP [I.8, I.9]. In particular, pragmatic assumptions are made regarding the extent of package damage and release of contents, as discussed later, without reference to a 'median' accident.

BASIS OF THE Q SYSTEM

I.8. Under the Q system a series of exposure routes are considered, each of which might lead to radiation exposure, either external or internal, to persons in the vicinity of a Type A package involved in a severe transport accident. The dosimetric routes are illustrated schematically in Fig. I.1 and lead to five contents limit values Q_A , Q_B , Q_C , Q_D and Q_E , for external photon dose, external beta dose, inhalation dose, skin and ingestion dose due to contamination transfer, and submersion dose, respectively. Contents limits for special form alpha and neutron emitters and tritium are considered separately.

I.9. Type A package contents limits are determined for individual radionuclides, as in the 1985 edition of the Regulations. The A_1 value for special form materials is the lesser of the two values Q_A and Q_B , while the A_2 value for non-special form radioactive materials is the least of the A_1 and the remaining Q values. Specific assumptions concerning the exposure pathways used in the derivation of individual Q values are discussed below, but all are based upon the following radiological criteria:

- (a) The effective or committed effective dose to a person exposed in the vicinity of a transport package following an accident should not exceed a reference dose of 50 mSv.
- (b) The dose or committed equivalent dose received by individual organs, including the skin, of a person involved in the accident should not exceed 0.5 Sv, or in the special case of the lens of the eye 0.15 Sv.
- (c) A person is unlikely to remain at 1 m from the damaged package for more than 30 min.

I.10. In terms of the BSS [I.10], the Q system lies within the domain of potential exposures. A potential exposure is one that is not expected to be delivered with certainty but may result from an accident at a source or owing to an event or sequence of events of a probabilistic nature, including equipment failures and operating errors. For potential exposures, the dose limits set forth in the BSS are not relevant (see Schedule II, Table II-3 of the BSS). In the 1985 edition of the Regulations, the reference dose, used in the derivation of A_1/A_2 values, of 50 mSv for the effective dose or committed effective dose to a person exposed in the vicinity of a transport package following an accident, was linked to the annual dose limit for radiation workers. As stated earlier, this link to the annual dose limit for workers is no longer valid for potential exposures. In the revised Q system the reference dose of 50 mSv has been retained on the grounds that, historically, actual accidents involving Type A packages have led to very low exposures. In choosing a reference dose, it is also

important to take into account the probability of an individual being exposed as the result of a transport accident; such exposures may, in general, be considered as once in a lifetime exposures. Clearly, most individuals will never be exposed.

I.11. The effective dose to a person exposed in the vicinity of a transport package following an accident should not exceed 50 mSv. For calculational purposes the person is considered to be at a distance of 1 m from the damaged package and to remain at this location for 30 min. The effective dose is defined in the BSS as the summation of the tissue equivalent doses, each multiplied by the appropriate tissue weighting factor. The tissue weighting factors are those used in radiation protection as given in ICRP Publication 60 [I.8].

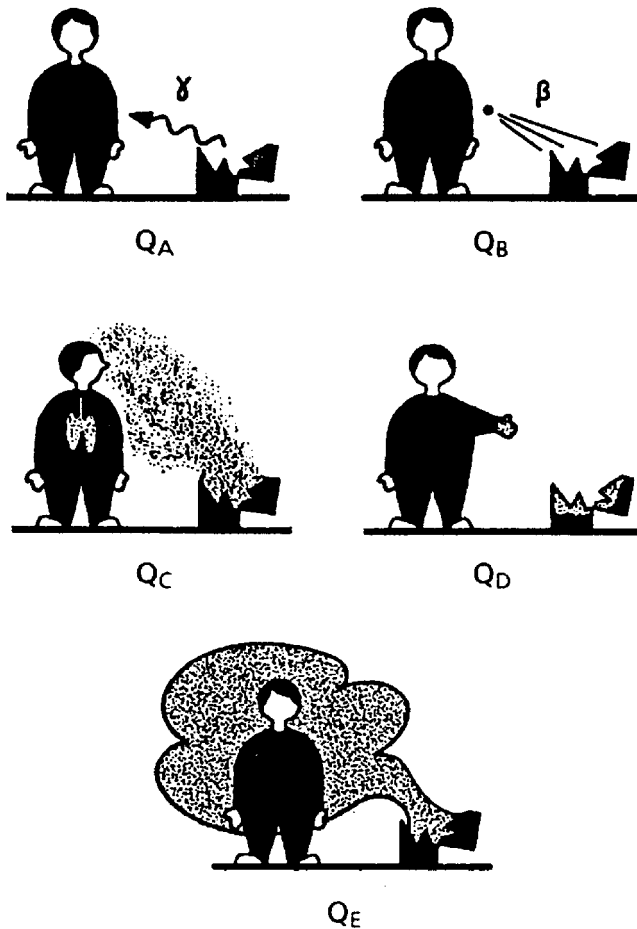

FIG. I.1. Schematic representation of exposure pathways employed in the Q system.

I.12. Further, the exposure period of 30 min at a distance of 1 m is a cautious judgement of the incidental exposure of persons initially present at the scene of an accident, it being assumed that subsequent recovery operations take place under health physics supervision and control. This is considered to be more realistic than the earlier assumption of exposure for 3 h at a distance of 3 m. Coupled with the dose limits cited above this leads to a limiting dose rate from the damaged package for whole body photon irradiation of 0.1 Sv/h at 1 m.

DOSIMETRIC MODELS AND ASSUMPTIONS

I.13. In this section the dosimetric models and assumptions underlying the derivation of five principal Q values are described in detail. The specific radiation pathways considered are outlined, and the considerations affecting the methods of derivation used are discussed.

Q_A — external dose due to photons

I.14. The Q_A value for a radionuclide is determined by consideration of the external radiation dose due to gamma or X rays to the whole body of a person exposed near a damaged Type A package following an accident. The shielding of the package is assumed to be completely lost in the accident and the consequent dose rate at a distance of 1 m from the edge (or surface) of the unshielded radioactive material is limited to 0.1 Sv/h. It is further assumed that the damaged package may be treated effectively as a point source.

I.15. In the earlier Q system, Q_A was calculated by using the mean photon energy per disintegration taken from ICRP Publication 38 [I.11]. Furthermore, the conversion to effective dose per unit exposure free-in-air was approximated as 6.7 m·Sv/R from photon energies between 50 keV and 5 MeV.

I.16. In the revised Q system, the Q_A values have been calculated using the complete X and gamma emission spectrum for the radionuclides as given in ICRP Publication 38. The energy dependent relationship between effective dose and exposure free-in-air is that given in ICRP Publication 51 [I.12] for an isotropic radiation geometry.

I.17. The Q_A values are given by

$$Q_A = \frac{D/t}{DRC_\gamma} C$$

where

D is the reference dose of 0.05 Sv,

t is the exposure time of 0.5 h,

DRC_γ is the effective dose rate coefficient for the radionuclide, and

C is a conversion factor that determines the units for Q_A .

I.18. Thus the Q_A values are determined by

$$Q_A (\text{TBq}) = \frac{10^{-13}}{\dot{e}_{\text{pt}}}$$

where \dot{e}_{pt} is the effective dose rate coefficient for the radionuclide at a distance of 1 m ($\text{Sv}\cdot\text{Bq}^{-1}\cdot\text{h}^{-1}$).

I.19. Dose and dose rate coefficients may be found in Table II.2 of Appendix II.

I.20. In this equation the value for C was set to 10^{-12} TBq/Bq.

I.21. The dose rate coefficient has been calculated from

$$\dot{e}_{\text{pt}} = \frac{C}{4\pi d^2} \sum_i \left(\frac{e}{X} \right)_{E_i} Y_i E_i \left(\frac{\mu_{\text{en}}}{\rho} \right)_{E_i} e^{-\mu_i d} B(E_i, d)$$

where

$(e/X)_{E_i}$ is the relationship between the effective dose and exposure free-in-air ($\text{Sv}\cdot\text{R}^{-1}$),

Y_i is the yield of photons of energy E_i per disintegration of the radionuclide ($\text{Bq}\cdot\text{s})^{-1}$,

E_i is the energy of the photon (MeV),

$(\mu_{\text{en}}/\rho)_{E_i}$ is the mass energy absorption coefficient in air for photons of energy E_i ($\text{cm}^2\cdot\text{g}^{-1}$),

$^{-\mu}_i$ is the linear attenuation coefficient in air for photons of energy E_i (cm^{-1}),

$B(E_i, d)$ is the air kerma buildup factor for photons of energy E_i and distance d, and

C is a constant given by the above units.

I.22. The distance d is taken as 1 m. The values of $(e/X)_{E_i}$ are obtained by interpolating the data from ICRP Publication 51 [I.12]. This approach is valid for photons in the range 5 keV to 10 MeV. The value of $(e/X)_{E_i}$ depends on the assumptions regarding the angular distribution of the radiation field (the exposure geometry). However, the numerical differences are rather minor between various exposure geometries, e.g. the ratio of a rotational parallel beam to isotropic field is typically less than 1.3.

Q_B — external dose due to beta emitters

I.23. The Q_B value is determined by consideration of the beta dose to the skin of a person exposed following an accident involving a Type A package containing special form radioactive material. The shielding of the transport package is again assumed to be completely lost in the accident, but the concept of a residual shielding factor for beta emitters (associated with materials such as the beta window protector, package debris, etc.) included in the 1985 edition of the Regulations is retained. These assumed a very conservative shielding factor of 3 for beta emitters of maximum energy ≥ 2 MeV, and within the Q system this practice is extended to include a range of shielding factors dependent on beta energy based on an absorber of approximately $150 \text{ mg}\cdot\text{cm}^{-2}$ thickness.

I.24. In the revised Q system, Q_B is calculated by using the complete beta spectra for the radionuclides of ICRP Publication 38 (see Ref. [I.13]). The spectral data for the nuclide of interest are used with data from Refs [I.14, I.15] on the skin dose rate per unit activity of a monoenergetic electron emitter. The self-shielding of the package was taken to be a smooth function of the maximum energy of the beta spectrum (Fig. I.2). Q_B is given by

$$Q_B = \frac{D/t}{\text{DRC}_\beta} C$$

where

D is the reference dose of 0.5 Sv,

t is the exposure time of 0.5 h,

DRC_β is the effective dose rate coefficient for the radionuclide, and

C is a conversion factor that determines the units for Q_B .

1.25. Thus, Q_B is calculated from

$$Q_B(\text{TBq}) = \frac{1 \times 10^{-12}}{\dot{e}_\beta}$$

where \dot{e}_β is the effective skin dose rate coefficient for beta emission at a distance of 1 m from the self-shielded material ($\text{Sv}\cdot\text{Bq}^{-1}\cdot\text{h}^{-1}$).

Dose and dose rate coefficients may be found in Table II.2 of Appendix II.

1.26. In this equation, the value for C was set to 10^{-12} TBq/Bq .

1.27. The dose rate coefficient is defined as

$$\dot{e}_\beta = \frac{1}{SF_{\beta_{\max}}} J_{\text{air}} C$$

where

$SF_{\beta_{\max}}$ is the shielding factor computed at the maximum energy of the beta spectrum,

J_{air} is the dose at 1 m per disintegration ($\text{MeV}\cdot\text{g}^{-1}\cdot\text{Bq}^{-1}\cdot\text{s}^{-1}$), and

C is a numerical conversion constant.

The factor J_{air} is computed as

$$J_{\text{air}} = \frac{n}{4\pi\rho r^2} \int_0^{E_{\max}} N(E)j(r/r_E, E)(E/r_E)dE$$

where

n is the number of beta particles emitted per disintegration,

$N(E)$ is the number of electrons emitted with energy between E and $E + dE$ ($\text{Bq}^{-1}\cdot\text{s}^{-1}$),

and

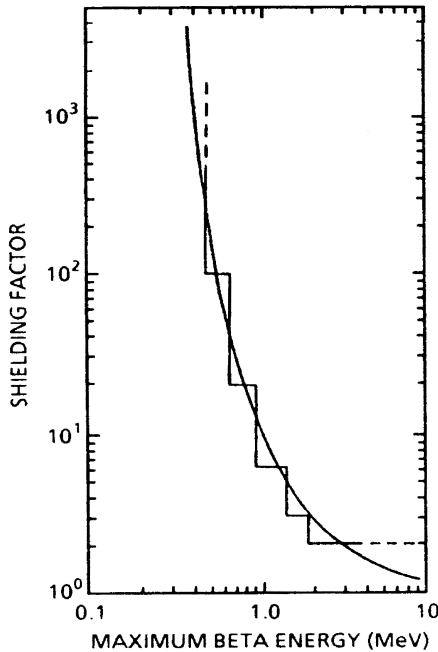

FIG. 1.2. Shielding factor as a function of beta energy. Shielding factor = $e^{\mu d}$, $\mu = 0.017 \times E_{\beta_{\max}}^{-1.14}$, $d = 150 \text{ mg/cm}^2$.

$j(r/r_E, E)$ is the dimensionless dose distribution which represents the fraction of emitted energy deposited in a spherical shell of radius r/r_E and $r/r_E + d(r/r_E)$ as tabulated by Cross [I.14, I.15].

I.28. It should be noted that, although the dose limit for the lens of the eye is lower than that for the skin (0.15 Sv as compared with 0.5 Sv), consideration of the depth doses in tissues for beta emitters and in particular the absorption at the 300 mg·cm⁻² depth of the sensitive cells of the lens epithelium indicates that the dose to the skin is always limiting for maximum beta energies up to approximately 4 MeV [I.16–I.18]. Specific consideration of the dose to the lens of the eye is thus unnecessary.

I.29. Finally, mention should be made of the treatment of positron annihilation radiation and conversion electrons in the determination of Q values. The latter are treated as monoenergetic beta particles, and weighted according to their yields. In the case of annihilation radiation this has not been included in the evaluation of the beta dose to the skin since it contributes only an additional few per cent to the local dose to the basal layer. However, the 0.51 MeV gamma rays are included in the photon energy per disintegration used in the derivation of Q_A as discussed above.

Q_C — internal dose via inhalation

I.30. The Q_C value for a radionuclide transported in a non-special form is determined by consideration of the inhalation dose to a person exposed to the radioactive material released from a damaged Type A package following an accident. Compliance with the limiting doses cited earlier was ensured by restricting the intake of radioactive material under accident conditions to the ALI recommended by the ICRP [I.19]. The concept of the ‘median’ accident used in the 1973 edition of the Regulations is no longer used since its definition involved a circular argument, namely that a median accident was one leading to a release of 10⁻³ of the package contents coupled with a dosimetric model which assumed that such an accident released 10⁻³ of the package contents and that 10⁻³ of this release was incorporated into a person.

I.31. Under the Q system a range of accident scenarios is considered, including that originally proposed for the derivation of Q_C , encompassing accidents occurring both indoors and out of doors and including the possible effects of fires. In the 1973 edition of the Regulations, it was assumed that 10⁻³ of the package contents might escape as a result of a median accident and that 10⁻³ of this material might be taken into the body of a person involved in the accident. This results in a net intake factor of 10⁻⁶ of the package contents and this value has been retained within the Q system.

However, it is now recognized as representing a range of possible release fractions and uptake factors and it is convenient to consider intake factors in terms of these two parameters independently.

I.32. The range of release fractions now recognized under the Q system, namely 10^{-3} – 10^{-2} , covers that represented by the earlier assumption in the 1973 edition of the Regulations and the original proposal within the Q system. Underlying this is the tacit assumption, also contained in the 1985 edition of the Regulations, that the likelihood of a ‘major accident’ which could cause the escape of a large part of the package contents is small. To a large extent this approach is borne out by the behaviour of Type A packages in severe accident environments [I.20–I.22].

I.33. Data on the respirable aerosol fractions produced under accident conditions are generally sparse and are only available for a limited range of materials. For example, for uranium and plutonium specimens under enhanced oxidation rate conditions in air and carbon dioxide, respirable aerosol fractions up to approximately 1% have been reported [I.23]. However, below this level the aerosol fractions showed wide variations dependent on the temperatures and local atmospheric flow conditions involved. In the case of liquids, higher fractional releases are obviously possible, but here the multiple barriers provided by the Type A package materials, including absorbents and double containment systems, remain effective even after severe impact or crushing accidents [I.22]. Indeed, in an example cited of an I-131 source which was completely crushed in a highway accident, less than 2% of the package contents remained on the road after removal of the package debris [I.24].

I.34. Potentially the most severe accident environment for many Type A packages is the combination of severe mechanical damage with a fire. However, even in this situation the role of debris may be significant in retaining released radioactive material, as appeared to have happened in the 1979 DC8 aircraft accident in Athens [I.21, I.22].

I.35. Frequently, fires produce relatively large sized particulate material which would tend to minimize any intake via inhalation, while at the same time providing a significant surface area for the absorption of volatile species and particularly of vaporized liquids. A further mitigatory factor is the enhanced local dispersion associated with the convective air currents due to the fire, which would also tend to reduce intake via inhalation.

I.36. On the basis of considerations of the type outlined here, a release fraction in the range of 10^{-3} – 10^{-2} was assumed to be appropriate for the determination of Type A package contents limits within the Regulations.

I.37. The 10^{-4} – 10^{-3} range of uptake factors now used within the Q system is based upon consideration of a range of possible accident situations, both indoors and out of doors. The original Q system proposals considered exposure within a store room or cargo handling bay of 300 m³ volume with four room air changes per hour. Assuming an adult breathing rate of 3.3×10^{-4} m³/s, this results in an uptake factor of approximately 10^{-3} for a 30 min exposure period. An alternative accident scenario might involve exposure in a transport vehicle of 50 m³ volume with ten air changes per hour, as originally employed in the determination of the Type B package normal transport leakage limit in the 1985 edition of the Regulations. Using the same breathing rate and exposure period as above, this leads to an uptake factor of 2.4×10^{-3} , of the same order as the value obtained above.

I.38. For accidents occurring out of doors the most conservative assumption for the atmospheric dispersion of released material is that of a ground level point source. Tabulated dilution factors for this situation at a downwind distance of 100 m range from 7×10^{-4} to 1.7×10^{-2} s/m³ [I.25], corresponding to uptake factors in the range 2.3×10^{-7} to 5.6×10^{-6} for the adult breathing rate cited above. These values apply to short term releases and cover the range from highly unstable to highly stable weather conditions; the corresponding value for average conditions is 3.3×10^{-7} , towards the lower end of the range quoted above.

I.39. Extrapolation of the models employed to evaluate the atmospheric dilution factors used here to shorter downwind distances is unreliable, but reducing the exposure distance by an order of magnitude to 10 m would increase the above uptake factors by about a factor of 30. This indicates that as the downwind distance approaches a few metres the uptake factors would approach the 10^{-4} – 10^{-3} range used within the Q system. However, under these circumstances other factors which would tend to reduce the activity uptake come into effect and may even become dominant. The additional turbulence to be expected in the presence of a fire has been mentioned earlier. Similar reductions in airborne concentrations can be anticipated as a result of turbulence originating from the flow of air around any vehicle involved in an accident or from the effects of nearby buildings.

I.40. Thus on balance it is seen that uptake factors in the range of 10^{-4} – 10^{-3} appear reasonable for the determination of Type A package contents limits. Taken in conjunction with the release fractions discussed earlier, the overall intake factor of 10^{-6} was used, as in the 1985 edition of the Regulations. However, within the Q system this value represents a combination of releases typically in the range up to 10^{-3} – 10^{-2} of the package contents as a respirable aerosol, combined with an uptake factor of up to 10^{-4} – 10^{-3} of the released material. Together with the limiting doses

cited earlier, this leads to an expression for the contents limit based on inhalation of the form:

$$Q_C = \frac{D}{1 \times 10^{-6} DC_{inh}} C$$

where

D is the reference dose of 0.05 Sv,

1×10^{-6} is the fraction of the contents of a package that is inhaled,

DC_{inh} is the dose coefficient for inhalation, and

C is a conversion factor that determines the units for Q_C .

Thus, Q_C can be calculated as

$$Q_C(\text{TBq}) = \frac{5 \times 10^{-8}}{e_{inh}}$$

where e_{inh} is the effective dose coefficient for inhalation of the radionuclide (Sv/Bq). Values for e_{inh} may be found in Table II-III in Safety Series No. 115. Dose and dose rate coefficients may be found in Table II.2 of Appendix II.

I.41. In this equation, the value for C was set to 10^{-12} TBq/Bq.

I.42. The ranges of release and uptake noted above are, in part, determined by the chemical form of the materials and particle size of the aerosol. The chemical form consideration has a major influence on the dose per unit intake. The intake fraction derived above is consistent with the value used in the earlier Q system. In calculating Q_C the most restrictive chemical form has been assumed and the effective dose coefficients, for an aerosol characterized by an AMAD of 1 μm , where applicable, are assumed [I.9, I.10]. The 1 μm AMAD value used in the earlier Q system is retained even though other AMAD values can give more conservative dose coefficients for some radionuclides.

I.43. For uranium, the Q_C values are presented in terms of the lung absorption types (formerly referred to as lung clearance classes) assigned for the major chemical forms of uranium. This more detailed evaluation of Q_C was undertaken because of sensitivity of the dose per unit intake to the absorption type and the fact that the chemical form of uranium in transport is generally known.

Q_D — skin contamination and ingestion doses

I.44. The Q_D value for beta emitters is determined by consideration of the beta dose to the skin of a person contaminated with non-special form radioactive material as a

consequence of handling a damaged Type A package. The model proposed within the Q system assumes that 1% of the package contents are spread uniformly over an area of 1 m²; handling of the debris is assumed to result in contamination of the hands to 10% of this level [I.26]. It is further assumed that the exposed person is not wearing gloves but would recognize the possibility of contamination or wash the hands within a period of five hours.

I.45. Taken individually, these assumptions are somewhat arbitrary, but as a whole they represent a reasonable basis for estimating the level of skin contamination which might arise under accident conditions. This is $10^{-3} \times Q_D/m^2$, with a dose rate limit for the skin of 0.1 Sv/h based on a 5 h exposure period. In the 1985 edition of the Regulations, the conversion to dose was based on the maximum energy of the beta spectra in a histogram type presentation.

I.46. Values for Q_D have now been calculated using the beta spectra and discrete electron emissions for the radionuclides as tabulated by the ICRP [I.11, I.12]. The emission data for the nuclide of interest were used with data from Cross et al. [I.27] on the skin dose rate for monoenergetic electrons emitted from the surface of the skin. Q_D is given by

$$Q_D = \frac{D}{10^{-3} \times DRC_{\text{skin}} \times t} C$$

where

D is the reference dose of 0.5 Sv,

10^{-3} is the fraction of the package content distributed per unit area of the skin (m⁻²),

DRC_{skin} is the dose rate coefficient for skin contamination,

t is the exposure time of 1.8×10^4 s (5 h), and

C is a conversion factor that determines the units for Q_D .

I.47. Thus, Q_D can be determined from

$$Q_D (\text{TBq}) = \frac{2.8 \times 10^{-2}}{\dot{h}_{\text{skin}}}$$

where \dot{h}_{skin} is the skin dose rate per unit activity per unit area of the skin (Sv·s⁻¹·TBq⁻¹·m²).

Dose and dose rate coefficients may be found in Table II.2 of Appendix II.

I.48. In this equation, the value for C was set to 1.

I.49. It should be noted that for a number of radionuclides the Q_D values are more restrictive than those of the earlier Q system. These lower Q_D values are primarily associated with radionuclides which emit internal conversion electrons.

I.50. The models used in deriving the Q_D values here may also be employed to estimate the possible uptake of radioactive material via ingestion. Assuming that a person may ingest all the contamination from 10^{-3} m² (10 cm²) of skin over a 24 h period [I.26], the resultant intake is $10^{-6} \times Q_D$, compared with that via inhalation of $10^{-6} \times Q_C$ derived earlier. Since the dose per unit intake via inhalation is generally of the same order as, or greater than, that via ingestion [I.9], the inhalation pathway will normally be limiting for internal contamination because of beta emitters under the Q system. Where this does not apply, almost without exception $Q_D \ll Q_C$, and explicit consideration of the ingestion pathway is unnecessary.

Q_E — submersion dose due to gaseous isotopes

I.51. The Q_E value for gaseous isotopes which do not become incorporated into the body is determined by consideration of the submersion dose following their release in an accident when transported as non-special form radioactive materials in either a compressed or an uncompressed state. A rapid 100% release of the package contents into a store room or cargo handling bay of dimensions 3 m × 10 m × 10 m with four air changes per hour is assumed. This leads to an initial airborne concentration of $Q_E/300$ (m⁻³), which falls exponentially with a decay constant of 4 h⁻¹ as a result of ventilation over the subsequent 30 min exposure period to give a mean concentration level of $1.44 \times 10^{-3} Q_E$ (m⁻³). Over the same period the concentration leading to the dose limits cited earlier is $4000 \times \text{DAC}$ (Bq/m³), where DAC was the derived air concentration recommended by the ICRP for 40 hours per week and 50 weeks per year occupational exposure in a 500 m³ room [I.2]. The use of the radiation protection quantity, DAC, is no longer appropriate, and therefore the present calculations use an effective dose coefficient for submersion in a semi-infinite cloud, from U.S.E.P.A. Federal Guidance Report No. 12 [I.28], as shown in Table I.1.

Q_E is given by

$$Q_E = \frac{D}{d_f \times \text{DRC}_{\text{subm}}} \times C$$

where

D is the reference dose of 0.05 Sv (or 0.5 Sv where Q_E is limited by skin exposure),

d_f is the time integrated air concentration,

DRC_{subm} is the effective dose coefficient for submersion in $\text{Sv}\cdot\text{Bq}^{-1}\cdot\text{s}^{-1}\cdot\text{m}^3$ (or skin dose coefficient for submersion — not listed), and
 C is a conversion factor that determines the units for Q_E .

In this equation, the value for d_f was set to $2.6 \text{ Bq}\cdot\text{s}\cdot\text{m}^{-3}$ per Bq released for the defined room, and C was set to 10^{-12} TBq/Bq .

1.52 Thus, Q_E can be calculated from

$$Q_E (\text{TBq}) = \frac{1.9 \times 10^{-14}}{h_{\text{sub}}}$$

where h_{sub} is the effective dose coefficient for submersion in $\text{Sv}\cdot\text{Bq}^{-1}\cdot\text{s}^{-1}\cdot\text{m}^3$.
Dose and dose rate coefficients may be found in Table II.2 of Appendix II.

SPECIAL CONSIDERATIONS

1.53. The dosimetric models described in the previous section apply to the vast majority of radionuclides of interest and may be used to determine their Q values and associated A_1 and A_2 values. However, in a limited number of cases the models are inappropriate or require modification. The special considerations applying in such circumstances are discussed in this section.

TABLE I.1. DOSE COEFFICIENTS FOR SUBMERSION

Dose coefficients h_{sub} for submersion ($\text{Sv}\cdot\text{Bq}^{-1}\cdot\text{s}^{-1}\cdot\text{m}^3$)			
Nuclide	h_{sub}	Nuclide	h_{sub}
Ar-37	0	Xe-122	2.19×10^{-15}
Ar-39	1.15×10^{-16}	Xe-123	2.82×10^{-14}
Ar-41	6.14×10^{-14}	Xe-127	1.12×10^{-14}
Ar-42	no value	Xe-131m	3.49×10^{-16}
Kr-81	2.44×10^{-16}	Xe-133	1.33×10^{-15}
Kr-85	2.40×10^{-16}	Xe-135	1.10×10^{-14}
Kr-85m	6.87×10^{-15}	Rn-218	3.40×10^{-17}
Kr-87	3.97×10^{-14}	Rn-219	2.46×10^{-15}
		Rn-220	1.72×10^{-17}
		Rn-222	1.77×10^{-17}

Consideration of parent and progeny radionuclides

I.54. The earlier Q system assumed a maximum transport time of 50 d, and thus radioactive decay products with half-lives less than 10 d were assumed to be in equilibrium with their longer lived parents. In such cases the Q values were calculated for the parent and its progeny, and the limiting value was used in determining A_1 and A_2 of the parent. In cases where a daughter radionuclide has a half-life either greater than 10 d or greater than that of the parent nuclide, such progeny, with the parent, were considered to be mixture.

I.55. The 10 d half-life criterion is retained. Progeny radionuclides products with half-lives less than 10 d are assumed to be in secular equilibrium with the longer lived parent; however the daughter's contribution to each Q value is summed with that of the parent. This provides a means of accounting for progeny with branching fractions less than one; e.g. Ba-137m is produced in 0.946 of the decays of its parent Cs-137. If the parent's half-life is less than 10 d and the daughter's half-life is greater than 10 d then the mixture rule is to be used by the consignor. For example, a package containing Ca-47 (4.53 d) has been evaluated with its Sc-47 (3.351 d) daughter in transient equilibrium with the parent. A package containing Ge-77 (11.3 h) will be evaluated by the consignor as a mixture of Ge-77 and its daughter As-77 (38.8 h).

I.56. In some cases, a long lived daughter is produced by the decay of a short lived parent. In these cases, the potential contribution of the daughter to the exposure can not be assessed without knowledge of the transport time and the buildup of progeny nuclides. It is necessary to determine the transport time and the buildup of progeny nuclides for the package and establish the A_1/A_2 values using the mixture rule. As an example, consider Te-131m (30 h), which decays to Te-131 (25 min); the latter in turn decays to I-131 (8.04 d). The mixture rule should be applied by the consignor to this package with the I-131 activity derived on the basis of the transport time and the buildup of progeny nuclides. It should be noted that the above treatment of the decay chains, in some cases, differs from the BSS Table I of Schedule I. That table assumes that secular equilibrium exists for all chains. The decay chains for which the daughter's contribution is included in determining the Q value for the parent nuclide are listed in Table I.3.

Alpha emitters

I.57. For alpha emitters it is not in general appropriate to calculate Q_A or Q_B values for special form material, owing to their relatively weak gamma and beta emissions. In the 1973 edition of the Regulations an arbitrary upper limit for special form alpha

sources of $10^3 \times A_2$ was introduced. There is no dosimetric justification for this procedure, and in recognition of this, coupled with the good record in the transport of special form radioactive materials and the reduction in many Q_C values for alpha emitters resulting from the use of the latest ICRP Recommendations, a tenfold increase in the arbitrary factor of 10^3 above was used. Thus an additional Q value, $Q_F = 10^4 \times Q_C$, is defined for special form alpha emitters and is listed in the column headed Q_A where appropriate in the tabulation of Q values.

I.58. A radionuclide is defined as an alpha emitter if in greater than 10^{-3} of its decays it emits alpha particles or it decays to an alpha emitter. For example, Np-235, which decays by alpha emission in 1.4×10^{-5} of its decays, is not an alpha emitter for the purpose of the special forms consideration. Similarly Pb-212 is an alpha emitter since its daughter Bi-212 undergoes alpha decay. Overall, the special form limits for alpha emitters have increased with increases in Q_C .

I.59. Finally, with respect to the ingestion of alpha emitters, arguments analogous to those used for beta emitters in the discussion on Q_D apply and the inhalation rather than the ingestion pathway is always more restrictive; hence the latter is not explicitly considered.

Neutron emitters

I.60. In the case of neutron emitters it was originally suggested under the Q system that there were no known situations with (α,n) or (γ,n) sources or the spontaneous neutron emitter Cf-252 for which neutron dose would contribute significantly to the external or internal radiation pathways considered earlier [I.4]. However, neutron dose cannot be neglected in the case of Cf-252 sources. Data given in ICRP Publication 21 [I.29] for neutron and gamma emissions indicate a dose rate of 2.54×10^3 rem/h at 1 m from a 1 g Cf-252 source. Combined with the dose rate limit of 10 rem/h at this distance cited earlier, this led to a Q_A value for Cf-252 of 0.095 TBq. The increase of a factor of about 2 in the radiation weighting factor for neutrons recommended by ICRP [I.8] gives a current value of 4.7×10^{-2} for Q_A . This is more restrictive than the Q_F value of 28 TBq obtained on the basis of the revised expression for special form alpha emitters. The neutron component dominates the external dose due to a Cf-252 source and similar considerations apply to the two other potential spontaneous fission sources Cm-248 and Cf-254. The Q_A values for these radionuclides were evaluated assuming the same dose rate conversion factor per unit activity as for the Cf-252 source quoted above, with allowance for their respective neutron emission rates relative to that of this source.

Bremsstrahlung

I.61. The A_1 and A_2 values tabulated in the 1973 edition of the Regulations were subject to an upper cut-off limit of 1000 Ci in order to protect against possible effects of bremsstrahlung. Within the Q system this cut-off was retained at 40 TBq. It was recognized as an arbitrary cut-off and is not specifically associated with bremsstrahlung radiation or any other dosimetric consideration. It remains unchanged.

I.62. A preliminary evaluation of bremsstrahlung, in a manner consistent with the assumptions of Q_A and Q_B , indicates that the 40 TBq figure is a reasonable value. However, explicit inclusion of bremsstrahlung within the Q system might limit A_1 and A_2 for some nuclides to about 20 TBq, a factor of 2 lower. This analysis supports the use of an arbitrary cut-off.

Tritium and its compounds

I.63. During the development of the Q system it was considered that liquids containing tritium should be considered separately. The model used was a spill of a large quantity of tritiated water in a confined area, followed by a fire. Resulting from these assumptions the A_2 value for tritiated liquids was set in the 1985 edition of the Regulations at 40 TBq, with an additional condition that the concentration should be smaller than 1 TBq/L. For the 1996 edition of the Regulations, no change was considered necessary.

Radon and its progeny

I.64. As noted earlier, the derivation of Q_E applies to noble gases which are not incorporated into the body and whose progeny are either a stable nuclide or another noble gas. In a few cases this condition is not fulfilled and dosimetric routes other than external exposure due to submersion in a radioactive cloud must be considered [I.30]. The only case of practical importance within the context of the Regulations is that of Rn-222, where the lung dose associated with inhalation of the short lived radon progeny has received special consideration by the ICRP [I.31].

I.65. In the derivation of the Q values for Rn-222 here, account is taken of the daughter radionuclides listed in Table I.3. The corresponding Q_C value in the 1985 edition of the Regulations was calculated to be 3.6 TBq; however, allowing for a 100% release of radon, rather than the 10^{-3} – 10^{-2} aerosol release fraction incorporated in the Q_C model, this reduces to a Q_C value in the range 3.6×10^{-3} to 3.6×10^{-2} TBq. Further, treating Rn-222 plus its progeny as a noble gas resulted in a Q_E value of 4.2×10^{-3} TBq, towards the lower end of the range of Q_C values, and this is still the

Type A package non-special form limit cited for Rn-222 in the tabulation of Q values. Radon dosimetry is ongoing and these values may be revised in the future.

APPLICATIONS

Low specific activity materials with ‘unlimited’ A_1 or A_2 values

I.66. The 1973 edition of the Regulations recognized a category of materials whose specific activities are so low that it is inconceivable that an intake could occur which would give rise to a significant radiation hazard, namely low specific activity (LSA) materials. These were defined in terms of a model where it was assumed that it is most unlikely that a person would remain in a dusty atmosphere long enough to inhale more than 10 mg of material. Under these conditions, if the specific activity of the material is such that the mass intake is equivalent to the activity intake assumed to occur for a person involved in an accident with a Type A package, namely $10^{-6} A_2$, then this material should not present a greater hazard during transport than the quantities of radioactive material transported in Type A packages. This hypothetical model is retained within the Q system and leads to an LSA criterion limit of $10^{-4} \times Q_C/g$; thus the Q values for those radionuclides whose specific activity is below this level are listed as ‘unlimited’. In the cases where this criterion is satisfied the effective dose associated with an intake of 10 mg of the nuclide is less than the dose criterion of 50 mSv. Natural uranium and thorium, depleted uranium and other materials such as U-238, Th-232 and U-235, satisfy the above LSA criterion. Calculations using the latest dose coefficients listed in the Basic Safety Standards [I.10] and by the ICRP [I.9] indicate that unirradiated uranium enriched to <20% also satisfies the same criterion, on the basis of the isotopic mixtures given in ASTM C996-90 [I.32]. A_1 and A_2 values for irradiated reprocessed uranium should be calculated on the basis of the mixtures equation, taking into account uranium radionuclides and fission products.

I.67. The above excludes consideration of chemical toxicity, for which a daily intake limit of 2.5 mg was recommended by the ICRP [I.33].

I.68. A further consideration relevant to LSA materials in the context of the skin contamination model used in the derivation of Q_D is the mass of material which might be retained on the skin for any significant period of time. The consensus view of the Special Working Group meeting was that typically 1–10 mg/cm² of dirt present on the hands would be readily discernible and would be removed promptly by wiping or washing, irrespective of the possible activity. It was agreed that the upper extreme of this range was appropriate as a cut-off for the mass of material

retained on the skin, and in combination with the skin contamination model for Q_D discussed earlier this results in an LSA limit of $10^{-5} \times Q_D / g$. On this basis Q_D values for radionuclides for which this criterion applies are also listed as 'unlimited' in the tabulation of Q values.

Release rates for normal transport

I.69. In the determination of the maximum allowable release rate for Type B packages under the conditions of normal transport, in the 1973 edition of the Regulations, the most adverse expected condition was judged to be represented by a worker spending 20% of his or her working time in an enclosed vehicle of 50 m³ volume, with ten air changes per hour. The vehicle was considered to contain a Type B package leaking activity at a rate of r (Bq/h) and it was assumed conservatively that the resulting airborne activity concentration was in equilibrium at all times. On this basis the annual activity intake via inhalation I_a for a person working 2000 h per year with an average breathing rate of 1.25 m³/h was evaluated as

$$I_a = \frac{r}{50 \times 10} \times 1.25 \times 2000 \times 0.2$$

or

$$I_a = r$$

I.70. Thus the maximum activity of intake over one year is equal to the activity released in one hour. This intake was equated with the historic maximum permissible quarterly dose for occupational exposure (30 mSv to whole body, gonads and red bone marrow; 150 mSv to skin, thyroid and bone; and 80 mSv to other single organs), which from the determination of A_2 corresponded to an intake of $A_2 \times 10^{-6}$. Hence $r \leq A_2 \times 10^{-6}$ per hour.

I.71. This derivation assumes that all of the released material becomes airborne and is available for inhalation, which may be a gross overestimate for many materials. Also, equilibrium conditions are assumed to pertain at all times. These factors, together with the principle that leakage from Type B packages should be minimized, indicated that the exposure of transport workers would be only a small fraction of the ICRP limits for radiation workers [I.5]. In addition, this level of conservatism was considered adequate to cover the unlikely situation of several leaking packages contained in the same vehicle.

I.72. In the 1985 edition of the Regulations the maximum allowable release rates for Type B packages under normal transport conditions were unchanged, although some of the parameters used in the above derivation were updated. In particular, in

the then current recommendations of the ICRP [I.16] the earlier quarterly limits employed above were replaced by annual dose or intake limits for radiation workers. These in turn were incorporated into the improved method, known as the Q system, for evaluating the Type A package contents limit A_1 and A_2 values.

I.73. The dose criterion of 50 mSv used in the Q system is such that under the BSS the system lies within the domain of potential exposures. In determining the allowed routine release limits for Type B packages it is necessary to consider the most recent dose limits for workers of 20 mSv per year, averaged over 5 years [I.8]. The earlier models assume an extremely pessimistic exposure model of 2000 h per year. Retaining this value, together with exposure within a room of 30 m × 10 m × 10 m with four air changes per hour, and an adult breathing rate of 1.25 m³/h, the permitted release rate, r , for an effective dose of 20 mSv can be calculated as follows:

$$r = \frac{20 \times 10^{-6} A_2}{50} \times \frac{3000 \times 4}{2000 \times 1.25} \text{ per hour}$$

$$r = 1.9 \times 10^{-6} A_2 \text{ per hour}$$

I.74. The room size assumed is larger than that assumed for an acute release under the Q system. However, the assumed exposure time is very pessimistic. Exposure for 200 h in a much more confined space of 300 m³ would lead to exactly the same predicted effective dose. For incidental exposure out of doors for persons in the vicinity of a leaking Type B package, the maximum inhalation dose would be very much lower.

I.75. The current limit of $10^{-6} A_2$ per hour is thus retained and is shown to be conservative. Experience shows that it is rare for packages in routine transport to leak at rates near the permitted limit. Indeed, such leakage for packages carrying liquids would lead to very severe surface contamination in the vicinity of the seals and would be readily obvious as a result of any radiological survey during transit or on receipt by the consignee.

Release rates for accident conditions

I.76. Accidents of the severity simulated in the Type B tests specified in the Regulations are unlikely to occur in a confined space indoors, or if they did the resulting conditions would be such as to necessitate immediate evacuation of all persons in the vicinity [I.2]. Hence the exposure scenario of interest in this context is that of an accident occurring out of doors. In this situation the radiological implications of the maximum allowable release of A_2 in a period of one week from a

Type B package may be expressed as an equivalent dose limit by consideration of the exposure to a person remaining continuously downwind of the damaged package throughout the period of the release [I.34].

I.77. In practice it is unlikely that any accidental release would persist for the full period of one week. In most situations emergency services personnel would attend the scene of an accident and take effective remedial actions to limit the release within a period of a few hours. On this basis the maximum effective dose via inhalation to persons exposed in the range of 50–200 m downwind from a damaged Type B package under average weather conditions is 1–10 mSv, increasing by a factor of about 5 under generally less probable and persistent stable meteorological conditions (see, for example, Fig. 3 of Ref. [I.35]). Local containment and atmospheric turbulence effects close to the radioactive source, plus possible plume rise effects if a fire were involved, will tend to minimize the spatial variation of doses beyond a few tens of metres from the source towards the lower end of the dose ranges cited above. The neglect of potential doses to persons within a few tens of metres of the source is considered justified in part by the conservative assumption of continuous exposure downwind of the source throughout the release period, and in part by the fact that emergency services personnel in this area should be working under health physics supervision and control.

I.78. The special provision in the case of Kr-85 which was introduced in the 1973 edition of the Regulations, and was retained in the 1985 edition of the Regulations, stems from consideration of the dosimetric consequences of a release of this radionuclide. The allowable release of $10 \times A_2$ was originally derived on the basis of a comparison of the potential radiation dose to the whole body, or any critical organ, of persons exposed within about 20 m of a source of Kr-85 and other non-gaseous radionuclides. In particular, it was noted that the inhalation pathway model used in the derivation of A_2 values at the time was inappropriate for a rare gas which is not significantly incorporated into body tissues. This criticism remains valid within the 1996 edition of the Regulations, where under the Q system the A_2 value for Kr-85 is equal to the Q_E value for the submersion dose to the skin of persons exposed indoors following the rapid release of the contents of a Type A package in an accident. It can be demonstrated that even the allowable release of $10 \times A_2$ for Kr-85 is highly conservative compared with the equivalent A_2 for other non-gaseous radionuclides. For a release of A_2 which is subject to a dilution factor d_f , the maximum resulting effective dose via inhalation D_{inh} is given by:

$$D_{inh} = A_2 \times d_f \times 3.3 \times 10^{-4} \times \frac{50}{A_2 \times 10^{-6}} (\text{mSv})$$

where 3.3×10^{-4} is the average adult breathing rate in m^3/s and an intake of $A_2 \times 10^{-6}$ has been equated with a dose of 50 mSv.

On the same basis, a release of $10 \times A_2$ for Kr-85 (100 TBq) results in a submersion dose given by:

$$D_{\text{subm}} = 100 \times d_f \times 2.4 \times 10^{-1} \text{ (mSv)}$$

where 2.4×10^{-1} is the submersion dose coefficient in $\text{mSv} \cdot \text{m}^3 \cdot \text{TBq}^{-1} \cdot \text{s}^{-1}$.

I.79. From the above expressions, $D_{\text{inh}}/D_{\text{subm}}$ is about 680. Thus the Type B package activity release limit for Kr-85 is seen to be conservative by more than two orders of magnitude in comparison with other non-gaseous radionuclides.

TABULATION OF Q VALUES

I.80. A full listing of Q values determined on the basis of the models described in the previous sections is given in Table I.2. Also included are the corresponding Type A package A_1 and A_2 contents limit values for special form and non-special form radioactive materials, respectively. The Q values shown in Table I.2 have been rounded to two significant figures and the A_1 and A_2 values to one significant figure; in the latter case the arbitrary 40 TBq cut-off has also been applied.

I.81. In general, the new values lie within a factor of about 3 of the earlier values; there are a few radionuclides where the new A_1 and A_2 values are outside this range. A few tens of radionuclides have new A_1 values higher than previous values by factors ranging between 10 and 100. This is mainly due to the improved modelling for beta emitters. There are no new A_1 or A_2 values lower than the previous figures by more than a factor of 10. A few radionuclides previously listed are now excluded but additional isomers are included, namely both isomers of Eu-150 and Np-236.

TABLE I.2. TYPE A PACKAGE CONTENTS LIMITS: Q_A , Q_B , Q_C , etc.
 Values and limits for special form (A_1) and non-special form (A_2) materials

Radio-nuclide	a - Q_F tabulated in place of Q_A	Q_A or Q_F (TBq)	Q_B (TBq)	Q_C (TBq)	Q_D or Q_E (TBq)	A_1 (TBq)	A_2 (TBq)
Ac-225		$4.9 \times 10^{+00}$	8.5×10^{-01}	6.3×10^{-03}	3.0×10^{-01}	8×10^{-01}	6×10^{-03}
Ac-227	a	9.3×10^{-01}	$1.3 \times 10^{+02}$	9.3×10^{-05}	$3.7 \times 10^{+01}$	9×10^{-01}	9×10^{-05}
Ac-228		$1.2 \times 10^{+00}$	5.6×10^{-01}	$2.0 \times 10^{+00}$	5.2×10^{-01}	6×10^{-01}	5×10^{-01}
Ag-105		$2.0 \times 10^{+00}$	$1.0 \times 10^{+03}$	$6.3 \times 10^{+01}$	$2.5 \times 10^{+01}$	$2 \times 10^{+00}$	$2 \times 10^{+00}$
Ag-108m		6.5×10^{-01}	$5.9 \times 10^{+00}$	$1.4 \times 10^{+00}$	$6.0 \times 10^{+00}$	7×10^{-01}	7×10^{-01}
Ag-110m		4.2×10^{-01}	$1.9 \times 10^{+01}$	$4.2 \times 10^{+00}$	$2.1 \times 10^{+00}$	4×10^{-01}	4×10^{-01}
Ag-111		$4.1 \times 10^{+01}$	$1.9 \times 10^{+00}$	$2.9 \times 10^{+01}$	6.2×10^{-01}	$2 \times 10^{+00}$	6×10^{-01}
Al-26		4.3×10^{-01}	1.4×10^{-01}	$2.8 \times 10^{+00}$	7.1×10^{-01}	1×10^{-01}	1×10^{-01}
Am-241	a	$1.3 \times 10^{+01}$	$1.0 \times 10^{+03}$	1.3×10^{-03}	$3.8 \times 10^{+02}$	$1 \times 10^{+01}$	1×10^{-03}
Am-242m	a	$1.4 \times 10^{+01}$	$5.0 \times 10^{+01}$	1.4×10^{-03}	8.4×10^{-01}	$1 \times 10^{+01}$	1×10^{-03}
Am-243		$5.0 \times 10^{+00}$	$2.6 \times 10^{+02}$	1.3×10^{-03}	4.1×10^{-01}	$5 \times 10^{+00}$	1×10^{-03}
Ar-37		$1.0 \times 10^{+03}$	$1.0 \times 10^{+03}$	—	$1.0 \times 10^{+03}$	$4 \times 10^{+01}$	$4 \times 10^{+01}$
Ar-39		—	$7.3 \times 10^{+01}$	—	$1.8 \times 10^{+01}$	$4 \times 10^{+01}$	$2 \times 10^{+01}$
Ar-41		8.8×10^{-01}	3.1×10^{-01}	—	3.1×10^{-01}	3×10^{-01}	3×10^{-01}
As-72		6.1×10^{-01}	2.8×10^{-01}	$5.4 \times 10^{+01}$	6.5×10^{-01}	3×10^{-01}	3×10^{-01}
As-73		$9.5 \times 10^{+01}$	$1.0 \times 10^{+03}$	$5.4 \times 10^{+01}$	$1.0 \times 10^{+03}$	$4 \times 10^{+01}$	$4 \times 10^{+01}$
As-74		$1.4 \times 10^{+00}$	$1.7 \times 10^{+00}$	$2.4 \times 10^{+01}$	9.4×10^{-01}	$1 \times 10^{+00}$	9×10^{-01}
As-76		$2.5 \times 10^{+00}$	2.5×10^{-01}	$6.8 \times 10^{+01}$	5.9×10^{-01}	3×10^{-01}	3×10^{-01}
As-77		$1.3 \times 10^{+02}$	$1.8 \times 10^{+01}$	$1.3 \times 10^{+02}$	6.5×10^{-01}	$2 \times 10^{+01}$	7×10^{-01}
At-211		$2.5 \times 10^{+01}$	$1.0 \times 10^{+03}$	5.1×10^{-01}	$4.4 \times 10^{+02}$	$2 \times 10^{+01}$	5×10^{-01}
Au-193		$7.0 \times 10^{+00}$	$1.0 \times 10^{+03}$	$4.2 \times 10^{+02}$	$1.8 \times 10^{+00}$	$7 \times 10^{+00}$	$2 \times 10^{+00}$
Au-194		$1.1 \times 10^{+00}$	$1.0 \times 10^{+03}$	$2.0 \times 10^{+02}$	$6.1 \times 10^{+00}$	$1 \times 10^{+00}$	$1 \times 10^{+00}$
Au-195		$1.3 \times 10^{+01}$	$1.0 \times 10^{+03}$	$3.1 \times 10^{+01}$	$5.5 \times 10^{+00}$	$1 \times 10^{+01}$	$6 \times 10^{+00}$
Au-198		$2.6 \times 10^{+00}$	$1.1 \times 10^{+00}$	$6.0 \times 10^{+01}$	6.1×10^{-01}	$1 \times 10^{+00}$	6×10^{-01}
Au-199		$1.4 \times 10^{+01}$	$1.0 \times 10^{+03}$	$6.7 \times 10^{+01}$	6.4×10^{-01}	$1 \times 10^{+01}$	6×10^{-01}
Ba-131		$1.6 \times 10^{+00}$	$1.0 \times 10^{+03}$	$1.9 \times 10^{+02}$	$2.2 \times 10^{+00}$	$2 \times 10^{+00}$	$2 \times 10^{+00}$
Ba-133		$2.6 \times 10^{+00}$	$1.0 \times 10^{+03}$	$3.3 \times 10^{+01}$	$1.0 \times 10^{+01}$	$3 \times 10^{+00}$	$3 \times 10^{+00}$
Ba-133m		$1.5 \times 10^{+01}$	$1.0 \times 10^{+03}$	$2.6 \times 10^{+02}$	6.2×10^{-01}	$2 \times 10^{+01}$	6×10^{-01}

TABLE I.2. (cont.)

Radio-nuclide	a - Q_F tabulated in place of Q_A	Q_A or Q_F (TBq)	Q_B (TBq)	Q_C (TBq)	Q_D or Q_E (TBq)	A_1 (TBq)	A_2 (TBq)
Ba-140		6.3×10^{-01}	4.5×10^{-01}	$2.4 \times 10^{+01}$	3.1×10^{-01}	5×10^{-01}	3×10^{-01}
Be-7		$2.1 \times 10^{+01}$	$1.0 \times 10^{+03}$	$9.4 \times 10^{+02}$	$1.0 \times 10^{+03}$	$2 \times 10^{+01}$	$2 \times 10^{+01}$
Be-10		—	$5.8 \times 10^{+01}$	$1.5 \times 10^{+00}$	5.8×10^{-01}	$4 \times 10^{+01}$	6×10^{-01}
Bi-205		6.9×10^{-01}	$1.0 \times 10^{+03}$	$5.4 \times 10^{+01}$	$1.1 \times 10^{+01}$	7×10^{-01}	7×10^{-01}
Bi-206		3.4×10^{-01}	$1.0 \times 10^{+03}$	$2.9 \times 10^{+01}$	$1.1 \times 10^{+00}$	3×10^{-01}	3×10^{-01}
Bi-207		7.1×10^{-01}	$1.0 \times 10^{+03}$	$9.4 \times 10^{+00}$	$5.0 \times 10^{+00}$	7×10^{-01}	7×10^{-01}
Bi-210		—	$1.3 \times 10^{+00}$	6.0×10^{-01}	6.2×10^{-01}	$1 \times 10^{+00}$	6×10^{-01}
Bi-210m		$4.3 \times 10^{+00}$	6.2×10^{-01}	1.6×10^{-02}	4.9×10^{-01}	6×10^{-01}	2×10^{-02}
Bi-212		$1.0 \times 10^{+00}$	6.5×10^{-01}	$1.7 \times 10^{+00}$	5.8×10^{-01}	7×10^{-01}	6×10^{-01}
Bk-247	a	$7.7 \times 10^{+00}$	$1.0 \times 10^{+03}$	7.7×10^{-04}	$1.4 \times 10^{+00}$	$8 \times 10^{+00}$	8×10^{-04}
Bk-249		$1.0 \times 10^{+03}$	$1.0 \times 10^{+03}$	3.3×10^{-01}	$1.2 \times 10^{+01}$	$4 \times 10^{+01}$	3×10^{-01}
Br-76		4.4×10^{-01}	6.3×10^{-01}	$1.2 \times 10^{+02}$	9.9×10^{-01}	4×10^{-01}	4×10^{-01}
Br-77		$3.4 \times 10^{+00}$	$1.0 \times 10^{+03}$	$5.7 \times 10^{+02}$	$2.3 \times 10^{+01}$	$3 \times 10^{+00}$	$3 \times 10^{+00}$
Br-82		4.1×10^{-01}	$1.0 \times 10^{+03}$	$7.8 \times 10^{+01}$	7.7×10^{-01}	4×10^{-01}	4×10^{-01}
C-11		$1.0 \times 10^{+00}$	$2.0 \times 10^{+00}$	$1.0 \times 10^{+03}$	5.8×10^{-01}	$1 \times 10^{+00}$	6×10^{-01}
C-14		—	$1.0 \times 10^{+03}$	$8.6 \times 10^{+01}$	$3.2 \times 10^{+00}$	$4 \times 10^{+01}$	$3 \times 10^{+00}$
Ca-41		$1.0 \times 10^{+03}$	$1.0 \times 10^{+03}$	Unlimited	Unlimited	Unlimited	Unlimited
Ca-45		$1.0 \times 10^{+03}$	$1.0 \times 10^{+03}$	$1.9 \times 10^{+01}$	$1.2 \times 10^{+00}$	$4 \times 10^{+01}$	$1 \times 10^{+00}$
Ca-47		$2.7 \times 10^{+00}$	$3.7 \times 10^{+01}$	$2.0 \times 10^{+01}$	3.3×10^{-01}	$3 \times 10^{+00}$	3×10^{-01}
Cd-109		$2.9 \times 10^{+01}$	$1.0 \times 10^{+03}$	$6.2 \times 10^{+00}$	$1.9 \times 10^{+00}$	$3 \times 10^{+01}$	$2 \times 10^{+00}$
Cd-113m		—	$9.1 \times 10^{+01}$	4.5×10^{-01}	6.9×10^{-01}	$4 \times 10^{+01}$	5×10^{-01}
Cd-115		$3.9 \times 10^{+00}$	$3.3 \times 10^{+00}$	$4.3 \times 10^{+01}$	3.9×10^{-01}	$3 \times 10^{+00}$	4×10^{-01}
Cd-115m		$5.0 \times 10^{+01}$	5.2×10^{-01}	$6.8 \times 10^{+00}$	6.1×10^{-01}	5×10^{-01}	5×10^{-01}
Ce-139		$6.8 \times 10^{+00}$	$1.0 \times 10^{+03}$	$2.8 \times 10^{+01}$	$2.2 \times 10^{+00}$	$7 \times 10^{+00}$	$2 \times 10^{+00}$
Ce-141		$1.6 \times 10^{+01}$	$3.2 \times 10^{+02}$	$1.4 \times 10^{+01}$	5.8×10^{-01}	$2 \times 10^{+01}$	6×10^{-01}
Ce-143		$3.7 \times 10^{+00}$	8.9×10^{-01}	$6.2 \times 10^{+01}$	6.0×10^{-01}	9×10^{-01}	6×10^{-01}
Ce-144		$2.2 \times 10^{+01}$	2.5×10^{-01}	$1.0 \times 10^{+00}$	3.8×10^{-01}	2×10^{-01}	2×10^{-01}
Cf-248	a	$6.1 \times 10^{+01}$	$1.0 \times 10^{+03}$	6.1×10^{-03}	$1.0 \times 10^{+03}$	$4 \times 10^{+01}$	6×10^{-03}

TABLE I.2. (cont.)

Radio-nuclide	a - Q _F tabulated in place of Q _A	Q _A or Q _F (TBq)	Q _B (TBq)	Q _C (TBq)	Q _D or Q _E (TBq)	A ₁ (TBq)	A ₂ (TBq)
Cf-249		$3.2 \times 10^{+00}$	$1.0 \times 10^{+03}$	7.6×10^{-04}	$4.6 \times 10^{+00}$	$3 \times 10^{+00}$	8×10^{-04}
Cf-250	a	$1.6 \times 10^{+01}$	$1.0 \times 10^{+03}$	1.6×10^{-03}	$1.0 \times 10^{+03}$	$2 \times 10^{+01}$	2×10^{-03}
Cf-251	a	$7.5 \times 10^{+00}$	$1.0 \times 10^{+03}$	7.5×10^{-04}	5.2×10^{-01}	$7 \times 10^{+00}$	7×10^{-04}
Cf-252		4.7×10^{-02}	$1.0 \times 10^{+03}$	2.8×10^{-03}	$5.2 \times 10^{+02}$	5×10^{-02}	3×10^{-03}
Cf-253	a	$4.2 \times 10^{+02}$	$1.0 \times 10^{+03}$	4.2×10^{-02}	$1.2 \times 10^{+00}$	$4 \times 10^{+01}$	4×10^{-02}
Cf-254		1.4×10^{-03}	$1.0 \times 10^{+03}$	1.4×10^{-03}	$1.0 \times 10^{+03}$	1×10^{-03}	1×10^{-03}
Cl-36		$1.0 \times 10^{+03}$	$1.0 \times 10^{+01}$	$7.2 \times 10^{+00}$	6.3×10^{-01}	$1 \times 10^{+01}$	6×10^{-01}
Cl-38		8.1×10^{-01}	2.2×10^{-01}	$1.0 \times 10^{+03}$	5.6×10^{-01}	2×10^{-01}	2×10^{-01}
Cm-240	a	$1.7 \times 10^{+02}$	$1.0 \times 10^{+03}$	1.7×10^{-02}	$1.0 \times 10^{+03}$	$4 \times 10^{+01}$	2×10^{-02}
Cm-241		$2.2 \times 10^{+00}$	$1.0 \times 10^{+03}$	$1.3 \times 10^{+00}$	$1.5 \times 10^{+00}$	$2 \times 10^{+00}$	$1 \times 10^{+00}$
Cm-242	a	$1.0 \times 10^{+02}$	$1.0 \times 10^{+03}$	1.0×10^{-02}	$1.0 \times 10^{+03}$	$4 \times 10^{+01}$	1×10^{-02}
Cm-243		$8.6 \times 10^{+00}$	$1.0 \times 10^{+03}$	1.3×10^{-03}	8.3×10^{-01}	$9 \times 10^{+00}$	1×10^{-03}
Cm-244	a	$1.6 \times 10^{+01}$	$1.0 \times 10^{+03}$	1.6×10^{-03}	$1.0 \times 10^{+03}$	$2 \times 10^{+01}$	2×10^{-03}
Cm-245	a	$9.1 \times 10^{+00}$	$1.0 \times 10^{+03}$	9.1×10^{-04}	$2.7 \times 10^{+00}$	$9 \times 10^{+00}$	9×10^{-04}
Cm-246	a	$9.1 \times 10^{+00}$	$1.0 \times 10^{+03}$	9.1×10^{-04}	$1.0 \times 10^{+03}$	$9 \times 10^{+00}$	9×10^{-04}
Cm-247		$3.2 \times 10^{+00}$	$1.6 \times 10^{+02}$	9.8×10^{-04}	Unlimited	$3 \times 10^{+00}$	1×10^{-03}
Cm-248		1.8×10^{-02}	$1.0 \times 10^{+03}$	2.5×10^{-04}	Unlimited	2×10^{-02}	3×10^{-04}
Co-55		5.4×10^{-01}	9.7×10^{-01}	$9.1 \times 10^{+01}$	7.7×10^{-01}	5×10^{-01}	5×10^{-01}
Co-56		3.3×10^{-01}	$1.5 \times 10^{+01}$	$7.8 \times 10^{+00}$	$2.9 \times 10^{+00}$	3×10^{-01}	3×10^{-01}
Co-57		$1.0 \times 10^{+01}$	$1.0 \times 10^{+03}$	$5.3 \times 10^{+01}$	$1.3 \times 10^{+01}$	$1 \times 10^{+01}$	$1 \times 10^{+01}$
Co-58		$1.1 \times 10^{+00}$	$7.8 \times 10^{+02}$	$2.5 \times 10^{+01}$	$3.8 \times 10^{+00}$	$1 \times 10^{+00}$	$1 \times 10^{+00}$
Co-58m		$1.0 \times 10^{+03}$	$1.0 \times 10^{+03}$	$1.0 \times 10^{+03}$	$1.0 \times 10^{+03}$	$4 \times 10^{+01}$	$4 \times 10^{+01}$
Co-60		4.5×10^{-01}	$7.3 \times 10^{+02}$	$1.7 \times 10^{+00}$	9.7×10^{-01}	4×10^{-01}	4×10^{-01}
Cr-51		$3.4 \times 10^{+01}$	$1.0 \times 10^{+03}$	$1.0 \times 10^{+03}$	$1.0 \times 10^{+03}$	$3 \times 10^{+01}$	$3 \times 10^{+01}$
Cs-129		$3.6 \times 10^{+00}$	$1.0 \times 10^{+03}$	$1.0 \times 10^{+03}$	$3.7 \times 10^{+01}$	$4 \times 10^{+00}$	$4 \times 10^{+00}$
Cs-131		$3.1 \times 10^{+01}$	$1.0 \times 10^{+03}$	$1.0 \times 10^{+03}$	$1.0 \times 10^{+03}$	$3 \times 10^{+01}$	$3 \times 10^{+01}$
Cs-132		$1.5 \times 10^{+00}$	$1.0 \times 10^{+03}$	$2.1 \times 10^{+02}$	$2.5 \times 10^{+01}$	$1 \times 10^{+00}$	$1 \times 10^{+00}$
Cs-134		6.9×10^{-01}	$3.6 \times 10^{+00}$	$7.4 \times 10^{+00}$	9.2×10^{-01}	7×10^{-01}	7×10^{-01}
Cs-134m		$3.7 \times 10^{+01}$	$1.0 \times 10^{+03}$	$1.0 \times 10^{+03}$	6.3×10^{-01}	$4 \times 10^{+01}$	6×10^{-01}
Cs-135		—	$1.0 \times 10^{+03}$	Unlimited	$1.5 \times 10^{+00}$	$4 \times 10^{+01}$	$1 \times 10^{+00}$
Cs-136		5.1×10^{-01}	$8.3 \times 10^{+02}$	$3.8 \times 10^{+01}$	7.0×10^{-01}	5×10^{-01}	5×10^{-01}
Cs-137		$1.8 \times 10^{+00}$	$8.2 \times 10^{+00}$	$1.0 \times 10^{+01}$	6.3×10^{-01}	$2 \times 10^{+00}$	6×10^{-01}

TABLE I.2. (cont.)

Radio-nuclide	$a - Q_F$ tabulated in place of Q_A	Q_A or Q_F (TBq)	Q_B (TBq)	Q_C (TBq)	Q_D or Q_E (TBq)	A_1 (TBq)	A_2 (TBq)
Cu-64		$5.6 \times 10^{+00}$	$1.1 \times 10^{+02}$	$4.2 \times 10^{+02}$	$1.1 \times 10^{+00}$	$6 \times 10^{+00}$	$1 \times 10^{+00}$
Cu-67		$1.0 \times 10^{+01}$	$4.1 \times 10^{+02}$	$8.6 \times 10^{+01}$	6.9×10^{-01}	$1 \times 10^{+01}$	7×10^{-01}
Dy-159		$2.0 \times 10^{+01}$	$1.0 \times 10^{+03}$	$1.4 \times 10^{+02}$	$1.0 \times 10^{+03}$	$2 \times 10^{+01}$	$2 \times 10^{+01}$
Dy-165		$4.1 \times 10^{+01}$	9.4×10^{-01}	$8.2 \times 10^{+02}$	6.1×10^{-01}	9×10^{-01}	6×10^{-01}
Dy-166		$3.4 \times 10^{+01}$	8.6×10^{-01}	$2.0 \times 10^{+01}$	3.4×10^{-01}	9×10^{-01}	3×10^{-01}
Er-169		$1.0 \times 10^{+03}$	$1.0 \times 10^{+03}$	$5.1 \times 10^{+01}$	9.5×10^{-01}	$4 \times 10^{+01}$	$1 \times 10^{+00}$
Er-171		$2.9 \times 10^{+00}$	8.3×10^{-01}	$2.3 \times 10^{+02}$	5.1×10^{-01}	8×10^{-01}	5×10^{-01}
Eu-147		$2.2 \times 10^{+00}$	$1.0 \times 10^{+03}$	$5.0 \times 10^{+01}$	$3.8 \times 10^{+00}$	$2 \times 10^{+00}$	$2 \times 10^{+00}$
Eu-148		5.1×10^{-01}	$1.0 \times 10^{+03}$	$1.9 \times 10^{+01}$	$1.9 \times 10^{+01}$	5×10^{-01}	5×10^{-01}
Eu-149		$1.5 \times 10^{+01}$	$1.0 \times 10^{+03}$	$1.9 \times 10^{+02}$	$7.4 \times 10^{+01}$	$2 \times 10^{+01}$	$2 \times 10^{+01}$
Eu-150 (34 y)		7.2×10^{-01}	$1.0 \times 10^{+03}$	$1.0 \times 10^{+00}$	$7.1 \times 10^{+00}$	7×10^{-01}	7×10^{-01}
Eu-150 (13 h)		$2.3 \times 10^{+01}$	$1.5 \times 10^{+00}$	$2.6 \times 10^{+02}$	6.9×10^{-01}	$2 \times 10^{+00}$	7×10^{-01}
Eu-152		9.6×10^{-01}	$1.7 \times 10^{+02}$	$1.3 \times 10^{+00}$	$1.3 \times 10^{+00}$	$1 \times 10^{+00}$	$1 \times 10^{+00}$
Eu-152m		$3.7 \times 10^{+00}$	8.1×10^{-01}	$2.3 \times 10^{+02}$	7.8×10^{-01}	8×10^{-01}	8×10^{-01}
Eu-154		9.0×10^{-01}	$1.6 \times 10^{+00}$	$1.0 \times 10^{+00}$	5.5×10^{-01}	9×10^{-01}	6×10^{-01}
Eu-155		$1.9 \times 10^{+01}$	$1.0 \times 10^{+03}$	$7.7 \times 10^{+00}$	$3.2 \times 10^{+00}$	$2 \times 10^{+01}$	$3 \times 10^{+00}$
Eu-156		8.8×10^{-01}	7.4×10^{-01}	$1.5 \times 10^{+01}$	6.7×10^{-01}	7×10^{-01}	7×10^{-01}
F-18		$1.0 \times 10^{+00}$	$2.8 \times 10^{+01}$	$8.3 \times 10^{+02}$	5.8×10^{-01}	$1 \times 10^{+00}$	6×10^{-01}
Fe-52		4.1×10^{-01}	3.2×10^{-01}	$7.6 \times 10^{+01}$	3.7×10^{-01}	3×10^{-01}	3×10^{-01}
Fe-55		$1.0 \times 10^{+03}$	$1.0 \times 10^{+03}$	$6.5 \times 10^{+01}$	$1.0 \times 10^{+03}$	$4 \times 10^{+01}$	$4 \times 10^{+01}$
Fe-59		9.4×10^{-01}	$4.4 \times 10^{+01}$	$1.4 \times 10^{+01}$	8.9×10^{-01}	9×10^{-01}	9×10^{-01}
Fe-60		$2.0 \times 10^{+02}$	$1.0 \times 10^{+03}$	2.1×10^{-01}	$3.7 \times 10^{+00}$	$4 \times 10^{+01}$	2×10^{-01}
Ga-67		$7.4 \times 10^{+00}$	$1.0 \times 10^{+03}$	$2.2 \times 10^{+02}$	$3.2 \times 10^{+00}$	$7 \times 10^{+00}$	$3 \times 10^{+00}$
Ga-68		$1.1 \times 10^{+00}$	4.6×10^{-01}	$9.8 \times 10^{+02}$	6.6×10^{-01}	5×10^{-01}	5×10^{-01}
Ga-72		4.3×10^{-01}	3.7×10^{-01}	$9.1 \times 10^{+01}$	6.2×10^{-01}	4×10^{-01}	4×10^{-01}
Gd-146		5.3×10^{-01}	$2.9 \times 10^{+02}$	$7.3 \times 10^{+00}$	$1.0 \times 10^{+00}$	5×10^{-01}	5×10^{-01}
Gd-148	a	$2.0 \times 10^{+01}$	—	2.0×10^{-03}	—	$2 \times 10^{+01}$	2×10^{-03}
Gd-153		$9.5 \times 10^{+00}$	$1.0 \times 10^{+03}$	$2.4 \times 10^{+01}$	$8.9 \times 10^{+00}$	$1 \times 10^{+01}$	$9 \times 10^{+00}$
Gd-159		$2.1 \times 10^{+01}$	$3.1 \times 10^{+00}$	$1.9 \times 10^{+02}$	6.4×10^{-01}	$3 \times 10^{+00}$	6×10^{-01}

TABLE I.2. (cont.)

Radio-nuclide	a - Q _F tabulated in place of Q _A	Q _A or Q _F (TBq)	Q _B (TBq)	Q _C (TBq)	Q _D or Q _E (TBq)	A ₁ (TBq)	A ₂ (TBq)
Ge-68		$1.1 \times 10^{+00}$	4.6×10^{-01}	$3.8 \times 10^{+00}$	6.6×10^{-01}	5×10^{-01}	5×10^{-01}
Ge-71		$5.2 \times 10^{+02}$	$1.0 \times 10^{+03}$	$1.0 \times 10^{+03}$	$1.0 \times 10^{+03}$	$4 \times 10^{+01}$	$4 \times 10^{+01}$
Ge-77		$1.1 \times 10^{+00}$	3.3×10^{-01}	$1.4 \times 10^{+02}$	6.0×10^{-01}	3×10^{-01}	3×10^{-01}
Hf-172		5.8×10^{-01}	$1.0 \times 10^{+03}$	$1.5 \times 10^{+00}$	$1.7 \times 10^{+00}$	6×10^{-01}	6×10^{-01}
Hf-175		$2.9 \times 10^{+00}$	$1.0 \times 10^{+03}$	$4.5 \times 10^{+01}$	$4.7 \times 10^{+00}$	$3 \times 10^{+00}$	$3 \times 10^{+00}$
Hf-181		$1.9 \times 10^{+00}$	$1.0 \times 10^{+03}$	$1.1 \times 10^{+01}$	5.0×10^{-01}	$2 \times 10^{+00}$	5×10^{-01}
Hf-182		$4.6 \times 10^{+00}$	$1.0 \times 10^{+03}$	Unlimited	Unlimited	Unlimited	Unlimited
Hg-194		$1.1 \times 10^{+00}$	$1.0 \times 10^{+03}$	$1.3 \times 10^{+00}$	$6.1 \times 10^{+00}$	$1 \times 10^{+00}$	$1 \times 10^{+00}$
Hg-195m		$3.1 \times 10^{+00}$	$1.0 \times 10^{+03}$	$5.3 \times 10^{+00}$	7.3×10^{-01}	$3 \times 10^{+00}$	7×10^{-01}
Hg-197		$1.6 \times 10^{+01}$	$1.0 \times 10^{+03}$	$1.1 \times 10^{+01}$	$1.6 \times 10^{+01}$	$2 \times 10^{+01}$	$1 \times 10^{+01}$
Hg-197m		$1.3 \times 10^{+01}$	$1.0 \times 10^{+03}$	$8.1 \times 10^{+00}$	3.5×10^{-01}	$1 \times 10^{+01}$	4×10^{-01}
Hg-203		$4.6 \times 10^{+00}$	$1.0 \times 10^{+03}$	$6.7 \times 10^{+00}$	$1.1 \times 10^{+00}$	$5 \times 10^{+00}$	$1 \times 10^{+00}$
Ho-166		$3.8 \times 10^{+01}$	4.4×10^{-01}	$7.6 \times 10^{+01}$	5.8×10^{-01}	4×10^{-01}	4×10^{-01}
Ho-166m		6.2×10^{-01}	$1.0 \times 10^{+03}$	4.5×10^{-01}	$1.3 \times 10^{+00}$	6×10^{-01}	5×10^{-01}
I-123		$6.3 \times 10^{+00}$	$1.0 \times 10^{+03}$	$2.3 \times 10^{+02}$	$2.9 \times 10^{+00}$	$6 \times 10^{+00}$	$3 \times 10^{+00}$
I-124		$1.1 \times 10^{+00}$	$6.0 \times 10^{+00}$	$3.8 \times 10^{+00}$	$2.5 \times 10^{+00}$	$1 \times 10^{+00}$	$1 \times 10^{+00}$
I-125		$1.6 \times 10^{+01}$	$1.0 \times 10^{+03}$	$3.3 \times 10^{+00}$	$1.0 \times 10^{+03}$	$2 \times 10^{+01}$	$3 \times 10^{+00}$
I-126		$2.3 \times 10^{+00}$	$6.4 \times 10^{+00}$	$1.7 \times 10^{+00}$	$1.3 \times 10^{+00}$	$2 \times 10^{+00}$	$1 \times 10^{+00}$
I-129		$2.9 \times 10^{+01}$	$1.0 \times 10^{+03}$	Unlimited	Unlimited	Unlimited	Unlimited
I-131		$2.8 \times 10^{+00}$	$2.0 \times 10^{+01}$	$2.3 \times 10^{+00}$	6.9×10^{-01}	$3 \times 10^{+00}$	7×10^{-01}
I-132		4.8×10^{-01}	4.4×10^{-01}	$1.8 \times 10^{+02}$	6.1×10^{-01}	4×10^{-01}	4×10^{-01}
I-133		$1.8 \times 10^{+00}$	7.3×10^{-01}	$1.1 \times 10^{+01}$	6.2×10^{-01}	7×10^{-01}	6×10^{-01}
I-134		4.2×10^{-01}	3.2×10^{-01}	$6.9 \times 10^{+02}$	5.9×10^{-01}	3×10^{-01}	3×10^{-01}
I-135		8.2×10^{-01}	6.2×10^{-01}	$5.2 \times 10^{+01}$	6.2×10^{-01}	6×10^{-01}	6×10^{-01}
In-111		$2.8 \times 10^{+00}$	$1.0 \times 10^{+03}$	$2.2 \times 10^{+02}$	$3.0 \times 10^{+00}$	$3 \times 10^{+00}$	$3 \times 10^{+00}$
In-113m		$4.1 \times 10^{+00}$	$1.0 \times 10^{+03}$	$1.0 \times 10^{+03}$	$1.6 \times 10^{+00}$	$4 \times 10^{+00}$	$2 \times 10^{+00}$
In-114m		$1.1 \times 10^{+01}$	$1.0 \times 10^{+03}$	$5.4 \times 10^{+00}$	4.8×10^{-01}	$1 \times 10^{+01}$	5×10^{-01}
In-115m		$6.5 \times 10^{+00}$	$1.0 \times 10^{+03}$	$8.3 \times 10^{+02}$	$1.0 \times 10^{+00}$	$7 \times 10^{+00}$	$1 \times 10^{+00}$
Ir-189		$1.3 \times 10^{+01}$	$1.0 \times 10^{+03}$	$9.1 \times 10^{+01}$	$1.8 \times 10^{+01}$	$1 \times 10^{+01}$	$1 \times 10^{+01}$
Ir-190		7.5×10^{-01}	$1.0 \times 10^{+03}$	$2.2 \times 10^{+01}$	7.5×10^{-01}	7×10^{-01}	7×10^{-01}
Ir-192		$1.3 \times 10^{+00}$	$4.6 \times 10^{+01}$	$8.1 \times 10^{+00}$	6.1×10^{-01}	$1 \times 10^{+00}$	6×10^{-01}
Ir-194		$1.2 \times 10^{+01}$	3.3×10^{-01}	$8.9 \times 10^{+01}$	5.9×10^{-01}	3×10^{-01}	3×10^{-01}

TABLE I.2. (cont.)

Radio-nuclide	$a - Q_F$ tabulated in place of Q_A	Q_A or Q_F (TBq)	Q_B (TBq)	Q_C (TBq)	Q_D or Q_E (TBq)	A_1 (TBq)	A_2 (TBq)
K-40		$7.3 \times 10^{+00}$	9.4×10^{-01}	Unlimited	Unlimited	9×10^{-01}	9×10^{-01}
K-42		$4.2 \times 10^{+00}$	2.2×10^{-01}	$3.8 \times 10^{+02}$	5.7×10^{-01}	2×10^{-01}	2×10^{-01}
K-43		$1.1 \times 10^{+00}$	7.3×10^{-01}	$3.3 \times 10^{+02}$	6.2×10^{-01}	7×10^{-01}	6×10^{-01}
Kr-81		$1.1 \times 10^{+02}$	$1.0 \times 10^{+03}$	—	$7.9 \times 10^{+01}$	$4 \times 10^{+01}$	$4 \times 10^{+01}$
Kr-85		$4.8 \times 10^{+02}$	$1.4 \times 10^{+01}$	—	$1.4 \times 10^{+01}$	$1 \times 10^{+01}$	$1 \times 10^{+01}$
Kr-85m		$7.5 \times 10^{+00}$	$7.6 \times 10^{+00}$	—	$2.8 \times 10^{+00}$	$8 \times 10^{+00}$	$3 \times 10^{+00}$
Kr-87		$1.5 \times 10^{+00}$	2.1×10^{-01}	—	4.8×10^{-01}	2×10^{-01}	2×10^{-01}
La-137		$3.0 \times 10^{+01}$	$1.0 \times 10^{+03}$	$5.7 \times 10^{+00}$	$1.0 \times 10^{+03}$	$3 \times 10^{+01}$	$6 \times 10^{+00}$
La-140		4.9×10^{-01}	3.7×10^{-01}	$4.5 \times 10^{+01}$	6.0×10^{-01}	4×10^{-01}	4×10^{-01}
Lu-172		5.9×10^{-01}	$1.0 \times 10^{+03}$	$3.3 \times 10^{+01}$	$2.2 \times 10^{+00}$	6×10^{-01}	6×10^{-01}
Lu-173		$8.0 \times 10^{+00}$	$1.0 \times 10^{+03}$	$2.2 \times 10^{+01}$	$1.7 \times 10^{+01}$	$8 \times 10^{+00}$	$8 \times 10^{+00}$
Lu-174		$8.5 \times 10^{+00}$	$1.0 \times 10^{+03}$	$1.3 \times 10^{+01}$	$2.9 \times 10^{+01}$	$9 \times 10^{+00}$	$9 \times 10^{+00}$
Lu-174m		$1.6 \times 10^{+01}$	$1.0 \times 10^{+03}$	$1.3 \times 10^{+01}$	$3.7 \times 10^{+01}$	$2 \times 10^{+01}$	$1 \times 10^{+01}$
Lu-177		$3.3 \times 10^{+01}$	$1.0 \times 10^{+03}$	$4.2 \times 10^{+01}$	7.3×10^{-01}	$3 \times 10^{+01}$	7×10^{-01}
Mg-28		3.7×10^{-01}	2.5×10^{-01}	$2.6 \times 10^{+01}$	3.2×10^{-01}	3×10^{-01}	3×10^{-01}
Mn-52		3.2×10^{-01}	$7.3 \times 10^{+02}$	$3.6 \times 10^{+01}$	$1.9 \times 10^{+00}$	3×10^{-01}	3×10^{-01}
Mn-53		$1.0 \times 10^{+03}$	$1.0 \times 10^{+03}$	Unlimited	Unlimited	Unlimited	Unlimited
Mn-54		$1.3 \times 10^{+00}$	$1.0 \times 10^{+03}$	$3.3 \times 10^{+01}$	$1.0 \times 10^{+03}$	$1 \times 10^{+00}$	$1 \times 10^{+00}$
Mn-56		6.7×10^{-01}	3.0×10^{-01}	$3.8 \times 10^{+02}$	6.0×10^{-01}	3×10^{-01}	3×10^{-01}
Mo-93		$8.6 \times 10^{+01}$	$1.0 \times 10^{+03}$	$2.3 \times 10^{+01}$	$1.0 \times 10^{+03}$	$4 \times 10^{+01}$	$2 \times 10^{+01}$
Mo-99		$6.2 \times 10^{+00}$	$1.3 \times 10^{+00}$	$5.1 \times 10^{+01}$	5.5×10^{-01}	$1 \times 10^{+00}$	6×10^{-01}
N-13		$1.0 \times 10^{+00}$	9.3×10^{-01}	—	5.8×10^{-01}	9×10^{-01}	6×10^{-01}
Na-22		5.0×10^{-01}	$3.8 \times 10^{+00}$	$3.8 \times 10^{+01}$	6.5×10^{-01}	5×10^{-01}	5×10^{-01}
Na-24		3.0×10^{-01}	2.0×10^{-01}	$1.7 \times 10^{+02}$	6.0×10^{-01}	2×10^{-01}	2×10^{-01}
Nb-93m		$4.9 \times 10^{+02}$	$1.0 \times 10^{+03}$	$3.1 \times 10^{+01}$	$1.0 \times 10^{+03}$	$4 \times 10^{+01}$	$3 \times 10^{+01}$
Nb-94		6.8×10^{-01}	$1.0 \times 10^{+03}$	$1.1 \times 10^{+00}$	7.0×10^{-01}	7×10^{-01}	7×10^{-01}
Nb-95		$1.4 \times 10^{+00}$	$1.0 \times 10^{+03}$	$3.1 \times 10^{+01}$	$4.0 \times 10^{+00}$	$1 \times 10^{+00}$	$1 \times 10^{+00}$
Nb-97		$1.6 \times 10^{+00}$	9.0×10^{-01}	$1.0 \times 10^{+03}$	6.1×10^{-01}	9×10^{-01}	6×10^{-01}

TABLE I.2. (cont.)

Radio-nuclide	a - Q _F tabulated in place of Q _A	Q _A or Q _F (TBq)	Q _B (TBq)	Q _C (TBq)	Q _D or Q _E (TBq)	A ₁ (TBq)	A ₂ (TBq)
Nd-147		$7.4 \times 10^{+00}$	$5.6 \times 10^{+00}$	$2.2 \times 10^{+01}$	6.5×10^{-01}	$6 \times 10^{+00}$	6×10^{-01}
Nd-149		$2.9 \times 10^{+00}$	6.3×10^{-01}	$5.6 \times 10^{+02}$	5.1×10^{-01}	6×10^{-01}	5×10^{-01}
Ni-59		$1.0 \times 10^{+03}$	$1.0 \times 10^{+03}$	Unlimited	Unlimited	Unlimited	Unlimited
Ni-63		—	$1.0 \times 10^{+03}$	$2.9 \times 10^{+01}$	$1.0 \times 10^{+03}$	$4 \times 10^{+01}$	$3 \times 10^{+01}$
Ni-65		$2.1 \times 10^{+00}$	4.4×10^{-01}	$5.7 \times 10^{+02}$	6.1×10^{-01}	4×10^{-01}	4×10^{-01}
Np-235		$1.4 \times 10^{+02}$	$1.0 \times 10^{+03}$	$1.3 \times 10^{+02}$	$1.0 \times 10^{+03}$	$4 \times 10^{+01}$	$4 \times 10^{+01}$
Np-236 (0.1 My)		$8.7 \times 10^{+00}$	$1.0 \times 10^{+03}$	1.7×10^{-02}	5.0×10^{-01}	$9 \times 10^{+00}$	2×10^{-02}
Np-236 (22 h)	a	$2.3 \times 10^{+01}$	$1.0 \times 10^{+03}$	$1.0 \times 10^{+01}$	$1.5 \times 10^{+00}$	$2 \times 10^{+01}$	$2 \times 10^{+00}$
Np-237		$2.4 \times 10^{+01}$	$1.0 \times 10^{+03}$	2.4×10^{-03}	Unlimited	$2 \times 10^{+01}$	2×10^{-03}
Np-239		$6.7 \times 10^{+00}$	$2.6 \times 10^{+02}$	$5.6 \times 10^{+01}$	4.1×10^{-01}	$7 \times 10^{+00}$	4×10^{-01}
Os-185		$1.5 \times 10^{+00}$	$1.0 \times 10^{+03}$	$3.3 \times 10^{+01}$	$2.3 \times 10^{+01}$	$1 \times 10^{+00}$	$1 \times 10^{+00}$
Os-191		$1.5 \times 10^{+01}$	$1.0 \times 10^{+03}$	$2.8 \times 10^{+01}$	$2.3 \times 10^{+00}$	$1 \times 10^{+01}$	$2 \times 10^{+00}$
Os-191m		$1.3 \times 10^{+02}$	$1.0 \times 10^{+03}$	$3.3 \times 10^{+02}$	$2.7 \times 10^{+01}$	$4 \times 10^{+01}$	$3 \times 10^{+01}$
Os-193		$1.5 \times 10^{+01}$	$1.6 \times 10^{+00}$	$9.8 \times 10^{+01}$	5.9×10^{-01}	$2 \times 10^{+00}$	6×10^{-01}
Os-194		$1.2 \times 10^{+01}$	3.1×10^{-01}	6.3×10^{-01}	5.9×10^{-01}	3×10^{-01}	3×10^{-01}
P-32		—	4.5×10^{-01}	$1.6 \times 10^{+01}$	6.0×10^{-01}	5×10^{-01}	5×10^{-01}
P-33		—	$1.0 \times 10^{+03}$	$3.6 \times 10^{+01}$	$1.2 \times 10^{+00}$	$4 \times 10^{+01}$	$1 \times 10^{+00}$
Pa-230	a	$1.7 \times 10^{+00}$	$1.0 \times 10^{+03}$	6.6×10^{-02}	$2.1 \times 10^{+00}$	$2 \times 10^{+00}$	7×10^{-02}
Pa-231		$3.8 \times 10^{+00}$	$1.0 \times 10^{+03}$	3.8×10^{-04}	$1.8 \times 10^{+01}$	$4 \times 10^{+00}$	4×10^{-04}
Pa-233		$5.4 \times 10^{+00}$	$1.0 \times 10^{+03}$	$1.4 \times 10^{+01}$	6.5×10^{-01}	$5 \times 10^{+00}$	7×10^{-01}
Pb-201		$1.5 \times 10^{+00}$	$1.0 \times 10^{+03}$	$7.7 \times 10^{+02}$	$3.3 \times 10^{+00}$	$1 \times 10^{+00}$	$1 \times 10^{+00}$
Pb-202		$9.0 \times 10^{+02}$	$1.0 \times 10^{+03}$	Unlimited	$1.6 \times 10^{+01}$	$4 \times 10^{+01}$	$2 \times 10^{+01}$
Pb-203		$3.6 \times 10^{+00}$	$1.0 \times 10^{+03}$	$5.5 \times 10^{+02}$	$2.6 \times 10^{+00}$	$4 \times 10^{+00}$	$3 \times 10^{+00}$
Pb-205		$8.3 \times 10^{+02}$	$1.0 \times 10^{+03}$	Unlimited	Unlimited	Unlimited	Unlimited
Pb-210		$2.4 \times 10^{+02}$	$1.3 \times 10^{+00}$	5.1×10^{-02}	6.2×10^{-01}	$1 \times 10^{+00}$	5×10^{-02}
Pb-212		$1.0 \times 10^{+00}$	7.0×10^{-01}	2.2×10^{-01}	2.7×10^{-01}	7×10^{-01}	2×10^{-01}
Pd-103		$4.7 \times 10^{+01}$	$1.0 \times 10^{+03}$	$1.2 \times 10^{+02}$	$1.0 \times 10^{+03}$	$4 \times 10^{+01}$	$4 \times 10^{+01}$
Pd-107		—	$1.0 \times 10^{+03}$	Unlimited	Unlimited	Unlimited	Unlimited
Pd-109		$7.0 \times 10^{+01}$	$1.9 \times 10^{+00}$	$1.4 \times 10^{+02}$	4.7×10^{-01}	$2 \times 10^{+00}$	5×10^{-01}

TABLE I.2. (cont.)

Radio-nuclide	a - Q_F tabulated in place of Q_A	Q_A or Q_F (TBq)	Q_B (TBq)	Q_C (TBq)	Q_D or Q_E (TBq)	A_1 (TBq)	A_2 (TBq)
Pm-143		$3.3 \times 10^{+00}$	$1.0 \times 10^{+03}$	$3.6 \times 10^{+01}$	$3.6 \times 10^{+02}$	$3 \times 10^{+00}$	$3 \times 10^{+00}$
Pm-144		6.7×10^{-01}	$1.0 \times 10^{+03}$	$6.4 \times 10^{+00}$	$3.4 \times 10^{+01}$	7×10^{-01}	7×10^{-01}
Pm-145		$2.6 \times 10^{+01}$	$1.0 \times 10^{+03}$	$1.5 \times 10^{+01}$	$1.0 \times 10^{+03}$	$3 \times 10^{+01}$	$1 \times 10^{+01}$
Pm-147		$1.0 \times 10^{+03}$	$1.0 \times 10^{+03}$	$1.1 \times 10^{+01}$	$1.7 \times 10^{+00}$	$4 \times 10^{+01}$	$2 \times 10^{+00}$
Pm-148m		8.3×10^{-01}	$7.6 \times 10^{+00}$	$9.1 \times 10^{+00}$	7.2×10^{-01}	8×10^{-01}	7×10^{-01}
Pm-149		$1.0 \times 10^{+02}$	$1.7 \times 10^{+00}$	$6.9 \times 10^{+01}$	6.2×10^{-01}	$2 \times 10^{+00}$	6×10^{-01}
Pm-151		$3.3 \times 10^{+00}$	$1.8 \times 10^{+00}$	$1.1 \times 10^{+02}$	6.1×10^{-01}	$2 \times 10^{+00}$	6×10^{-01}
Po-210	a	$1.7 \times 10^{+02}$	$1.0 \times 10^{+03}$	1.7×10^{-02}	$1.0 \times 10^{+03}$	$4 \times 10^{+01}$	2×10^{-02}
Pr-142		$2.0 \times 10^{+01}$	3.6×10^{-01}	$8.9 \times 10^{+01}$	6.0×10^{-01}	4×10^{-01}	4×10^{-01}
Pr-143		$1.0 \times 10^{+03}$	$3.0 \times 10^{+00}$	$2.2 \times 10^{+01}$	6.3×10^{-01}	$3 \times 10^{+00}$	6×10^{-01}
Pt-188		9.7×10^{-01}	$1.0 \times 10^{+03}$	$5.7 \times 10^{+01}$	7.8×10^{-01}	$1 \times 10^{+00}$	8×10^{-01}
Pt-191		$3.6 \times 10^{+00}$	$1.0 \times 10^{+03}$	$4.5 \times 10^{+02}$	$3.5 \times 10^{+00}$	$4 \times 10^{+00}$	$3 \times 10^{+00}$
Pt-193		$8.7 \times 10^{+02}$	$1.0 \times 10^{+03}$	$1.0 \times 10^{+03}$	$1.0 \times 10^{+03}$	$4 \times 10^{+01}$	$4 \times 10^{+01}$
Pt-193m		$9.1 \times 10^{+01}$	$1.0 \times 10^{+03}$	$3.8 \times 10^{+02}$	5.5×10^{-01}	$4 \times 10^{+01}$	5×10^{-01}
Pt-195m		$1.5 \times 10^{+01}$	$1.0 \times 10^{+03}$	$2.6 \times 10^{+02}$	4.8×10^{-01}	$1 \times 10^{+01}$	5×10^{-01}
Pt-197		$4.7 \times 10^{+01}$	$2.4 \times 10^{+01}$	$5.5 \times 10^{+02}$	6.3×10^{-01}	$2 \times 10^{+01}$	6×10^{-01}
Pt-197m		$1.3 \times 10^{+01}$	$1.0 \times 10^{+03}$	$1.0 \times 10^{+03}$	5.8×10^{-01}	$1 \times 10^{+01}$	6×10^{-01}
Pu-236	a	$2.8 \times 10^{+01}$	$1.0 \times 10^{+03}$	2.8×10^{-03}	$6.5 \times 10^{+02}$	$3 \times 10^{+01}$	3×10^{-03}
Pu-237		$2.3 \times 10^{+01}$	$1.0 \times 10^{+03}$	$1.4 \times 10^{+02}$	$1.2 \times 10^{+02}$	$2 \times 10^{+01}$	$2 \times 10^{+01}$
Pu-238	a	$1.2 \times 10^{+01}$	$1.0 \times 10^{+03}$	1.2×10^{-03}	$1.0 \times 10^{+03}$	$1 \times 10^{+01}$	1×10^{-03}
Pu-239	a	$1.1 \times 10^{+01}$	$1.0 \times 10^{+03}$	1.1×10^{-03}	Unlimited	$1 \times 10^{+01}$	1×10^{-03}
Pu-240	a	$1.1 \times 10^{+01}$	$1.0 \times 10^{+03}$	1.1×10^{-03}	Unlimited	$1 \times 10^{+01}$	1×10^{-03}
Pu-241		$1.0 \times 10^{+03}$	$1.0 \times 10^{+03}$	5.9×10^{-02}	$1.0 \times 10^{+03}$	$4 \times 10^{+01}$	6×10^{-02}
Pu-242	a	$1.1 \times 10^{+01}$	$1.0 \times 10^{+03}$	1.1×10^{-03}	Unlimited	$1 \times 10^{+01}$	1×10^{-03}
Pu-244		$3.1 \times 10^{+00}$	3.8×10^{-01}	1.1×10^{-03}	Unlimited	4×10^{-01}	1×10^{-03}
Ra-223		$3.9 \times 10^{+00}$	4.0×10^{-01}	7.2×10^{-03}	2.6×10^{-01}	4×10^{-01}	7×10^{-03}
Ra-224		$1.1 \times 10^{+00}$	4.3×10^{-01}	1.6×10^{-02}	2.7×10^{-01}	4×10^{-01}	2×10^{-02}
Ra-225		$1.2 \times 10^{+01}$	2.2×10^{-01}	3.6×10^{-03}	2.3×10^{-01}	2×10^{-01}	4×10^{-03}
Ra-226		6.5×10^{-01}	2.5×10^{-01}	2.7×10^{-03}	2.7×10^{-01}	2×10^{-01}	3×10^{-03}
Ra-228		$1.2 \times 10^{+00}$	5.6×10^{-01}	1.9×10^{-02}	5.2×10^{-01}	6×10^{-01}	2×10^{-02}
Rb-81		$1.7 \times 10^{+00}$	$1.5 \times 10^{+01}$	$1.0 \times 10^{+03}$	8.3×10^{-01}	$2 \times 10^{+00}$	8×10^{-01}

TABLE I.2. (cont.)

Radio-nuclide	a - Q _F tabulated in place of Q _A	Q _A or Q _F (TBq)	Q _B (TBq)	Q _C (TBq)	Q _D or Q _E (TBq)	A ₁ (TBq)	A ₂ (TBq)
Rb-83		$2.1 \times 10^{+00}$	$1.0 \times 10^{+03}$	$6.9 \times 10^{+01}$	$4.3 \times 10^{+02}$	$2 \times 10^{+00}$	$2 \times 10^{+00}$
Rb-84		$1.2 \times 10^{+00}$	$4.0 \times 10^{+01}$	$4.5 \times 10^{+01}$	$2.2 \times 10^{+00}$	$1 \times 10^{+00}$	$1 \times 10^{+00}$
Rb-86		$1.2 \times 10^{+01}$	4.8×10^{-01}	$5.2 \times 10^{+01}$	6.1×10^{-01}	5×10^{-01}	5×10^{-01}
Rb-87		—	$1.0 \times 10^{+03}$	Unlimited	Unlimited	Unlimited	Unlimited
Rb(nat)		—	$1.0 \times 10^{+03}$	Unlimited	Unlimited	Unlimited	Unlimited
Re-184		$1.2 \times 10^{+00}$	$1.0 \times 10^{+03}$	$2.8 \times 10^{+01}$	$1.7 \times 10^{+00}$	$1 \times 10^{+00}$	$1 \times 10^{+00}$
Re-184m		$2.8 \times 10^{+00}$	$1.0 \times 10^{+03}$	$8.2 \times 10^{+00}$	$1.2 \times 10^{+00}$	$3 \times 10^{+00}$	$1 \times 10^{+00}$
Re-186		$5.8 \times 10^{+01}$	$2.0 \times 10^{+00}$	$4.5 \times 10^{+01}$	5.9×10^{-01}	$2 \times 10^{+00}$	6×10^{-01}
Re-187		—	$1.0 \times 10^{+03}$	Unlimited	Unlimited	Unlimited	Unlimited
Re-188		$2.0 \times 10^{+01}$	3.5×10^{-01}	$9.1 \times 10^{+01}$	5.4×10^{-01}	4×10^{-01}	4×10^{-01}
Re-189		$3.2 \times 10^{+01}$	$2.5 \times 10^{+00}$	$1.2 \times 10^{+02}$	5.7×10^{-01}	$3 \times 10^{+00}$	6×10^{-01}
Re(nat)		—	$1.0 \times 10^{+03}$	Unlimited	Unlimited	Unlimited	Unlimited
Rh-99		$1.8 \times 10^{+00}$	$1.0 \times 10^{+03}$	$6.0 \times 10^{+01}$	$7.5 \times 10^{+00}$	$2 \times 10^{+00}$	$2 \times 10^{+00}$
Rh-101		$4.3 \times 10^{+00}$	$1.0 \times 10^{+03}$	$9.8 \times 10^{+00}$	$2.6 \times 10^{+00}$	$4 \times 10^{+00}$	$3 \times 10^{+00}$
Rh-102		5.0×10^{-01}	$1.0 \times 10^{+03}$	$3.1 \times 10^{+00}$	$5.4 \times 10^{+01}$	5×10^{-01}	5×10^{-01}
Rh-102m		$2.2 \times 10^{+00}$	$8.9 \times 10^{+00}$	$7.5 \times 10^{+00}$	$1.8 \times 10^{+00}$	$2 \times 10^{+00}$	$2 \times 10^{+00}$
Rh-103m		$4.5 \times 10^{+02}$	$1.0 \times 10^{+03}$	$1.0 \times 10^{+03}$	$1.0 \times 10^{+03}$	$4 \times 10^{+01}$	$4 \times 10^{+01}$
Rh-105		$1.4 \times 10^{+01}$	$1.8 \times 10^{+02}$	$1.5 \times 10^{+02}$	7.9×10^{-01}	$1 \times 10^{+01}$	8×10^{-01}
Rn-222		6.7×10^{-01}	2.6×10^{-01}	—	4.2×10^{-03}	3×10^{-01}	4×10^{-03}
Ru-97		$4.7 \times 10^{+00}$	$1.0 \times 10^{+03}$	$4.5 \times 10^{+02}$	$1.3 \times 10^{+01}$	$5 \times 10^{+00}$	$5 \times 10^{+00}$
Ru-103		$2.2 \times 10^{+00}$	$2.0 \times 10^{+02}$	$1.8 \times 10^{+01}$	$1.6 \times 10^{+00}$	$2 \times 10^{+00}$	$2 \times 10^{+00}$
Ru-105		$1.4 \times 10^{+00}$	$1.2 \times 10^{+00}$	$2.8 \times 10^{+02}$	6.1×10^{-01}	$1 \times 10^{+00}$	6×10^{-01}
Ru-106		$5.3 \times 10^{+00}$	2.2×10^{-01}	8.1×10^{-01}	5.7×10^{-01}	2×10^{-01}	2×10^{-01}
S-35		—	$1.0 \times 10^{+03}$	$3.8 \times 10^{+01}$	$3.0 \times 10^{+00}$	$4 \times 10^{+01}$	$3 \times 10^{+00}$
Sb-122		$2.4 \times 10^{+00}$	4.3×10^{-01}	$5.0 \times 10^{+01}$	6.2×10^{-01}	4×10^{-01}	4×10^{-01}
Sb-124		6.2×10^{-01}	7.2×10^{-01}	$8.2 \times 10^{+00}$	6.9×10^{-01}	6×10^{-01}	6×10^{-01}
Sb-125		$2.4 \times 10^{+00}$	$2.5 \times 10^{+02}$	$1.1 \times 10^{+01}$	$1.4 \times 10^{+00}$	$2 \times 10^{+00}$	$1 \times 10^{+00}$
Sb-126		3.8×10^{-01}	$1.3 \times 10^{+00}$	$1.8 \times 10^{+01}$	7.1×10^{-01}	4×10^{-01}	4×10^{-01}
Sc-44		5.1×10^{-01}	6.1×10^{-01}	$2.6 \times 10^{+02}$	6.2×10^{-01}	5×10^{-01}	5×10^{-01}
Sc-46		5.4×10^{-01}	$1.0 \times 10^{+03}$	$7.8 \times 10^{+00}$	8.5×10^{-01}	5×10^{-01}	5×10^{-01}
Sc-47		$1.1 \times 10^{+01}$	$1.7 \times 10^{+02}$	$7.1 \times 10^{+01}$	7.0×10^{-01}	$1 \times 10^{+01}$	7×10^{-01}

TABLE I.2. (cont.)

Radio-nuclide	$a - Q_F$ tabulated in place of Q_A	Q_A or Q_F (TBq)	Q_B (TBq)	Q_C (TBq)	Q_D or Q_E (TBq)	A_1 (TBq)	A_2 (TBq)
Sc-48		3.3×10^{-01}	9.0×10^{-01}	$4.5 \times 10^{+01}$	6.5×10^{-01}	3×10^{-01}	3×10^{-01}
Se-75		$2.9 \times 10^{+00}$	$1.0 \times 10^{+03}$	$3.6 \times 10^{+01}$	$1.0 \times 10^{+01}$	$3 \times 10^{+00}$	$3 \times 10^{+00}$
Se-79		—	$1.0 \times 10^{+03}$	$1.7 \times 10^{+01}$	$2.3 \times 10^{+00}$	$4 \times 10^{+01}$	$2 \times 10^{+00}$
Si-31		$1.0 \times 10^{+03}$	5.8×10^{-01}	$6.3 \times 10^{+02}$	6.0×10^{-01}	6×10^{-01}	6×10^{-01}
Si-32		—	$1.0 \times 10^{+03}$	4.5×10^{-01}	$1.6 \times 10^{+00}$	$4 \times 10^{+01}$	5×10^{-01}
Sm-145		$1.3 \times 10^{+01}$	$1.0 \times 10^{+03}$	$3.3 \times 10^{+01}$	$1.0 \times 10^{+03}$	$1 \times 10^{+01}$	$1 \times 10^{+01}$
Sm-147		$5.6 \times 10^{+01}$	—	Unlimited	—	Unlimited	Unlimited
Sm-151		$1.0 \times 10^{+03}$	$1.0 \times 10^{+03}$	$1.4 \times 10^{+01}$	$1.0 \times 10^{+03}$	$4 \times 10^{+01}$	$1 \times 10^{+01}$
Sm-153		$1.7 \times 10^{+01}$	$9.1 \times 10^{+00}$	$8.2 \times 10^{+01}$	6.1×10^{-01}	$9 \times 10^{+00}$	6×10^{-01}
Sn-113		$3.7 \times 10^{+00}$	$1.0 \times 10^{+03}$	$2.0 \times 10^{+01}$	$1.6 \times 10^{+00}$	$4 \times 10^{+00}$	$2 \times 10^{+00}$
Sn-117m		$7.1 \times 10^{+00}$	$1.0 \times 10^{+03}$	$2.2 \times 10^{+01}$	4.0×10^{-01}	$7 \times 10^{+00}$	4×10^{-01}
Sn-119m		$6.2 \times 10^{+01}$	$1.0 \times 10^{+03}$	$2.5 \times 10^{+01}$	$1.0 \times 10^{+03}$	$4 \times 10^{+01}$	$3 \times 10^{+01}$
Sn-121m		$1.4 \times 10^{+02}$	$1.0 \times 10^{+03}$	$1.1 \times 10^{+01}$	8.5×10^{-01}	$4 \times 10^{+01}$	9×10^{-01}
Sn-123		$1.6 \times 10^{+02}$	7.5×10^{-01}	$6.5 \times 10^{+00}$	6.1×10^{-01}	8×10^{-01}	6×10^{-01}
Sn-125		$3.6 \times 10^{+00}$	3.7×10^{-01}	$1.7 \times 10^{+01}$	6.2×10^{-01}	4×10^{-01}	4×10^{-01}
Sn-126		6.6×10^{-01}	5.9×10^{-01}	$1.9 \times 10^{+00}$	3.6×10^{-01}	6×10^{-01}	4×10^{-01}
Sr-82		9.7×10^{-01}	2.4×10^{-01}	$5.0 \times 10^{+00}$	5.9×10^{-01}	2×10^{-01}	2×10^{-01}
Sr-85		$2.1 \times 10^{+00}$	$1.0 \times 10^{+03}$	$6.5 \times 10^{+01}$	$8.5 \times 10^{+01}$	$2 \times 10^{+00}$	$2 \times 10^{+00}$
Sr-85m		$5.2 \times 10^{+00}$	$1.0 \times 10^{+03}$	$1.0 \times 10^{+03}$	$1.8 \times 10^{+01}$	$5 \times 10^{+00}$	$2 \times 10^{+00}$
Sr-87m		$3.3 \times 10^{+00}$	$1.0 \times 10^{+03}$	$1.0 \times 10^{+03}$	$3.3 \times 10^{+00}$	$3 \times 10^{+00}$	$3 \times 10^{+00}$
Sr-89		$1.0 \times 10^{+03}$	6.2×10^{-01}	$6.7 \times 10^{+00}$	6.1×10^{-01}	6×10^{-01}	6×10^{-01}
Sr-90		$1.0 \times 10^{+03}$	3.2×10^{-01}	3.3×10^{-01}	3.1×10^{-01}	3×10^{-01}	3×10^{-01}
Sr-91		$1.5 \times 10^{+00}$	3.0×10^{-01}	$1.2 \times 10^{+02}$	6.0×10^{-01}	3×10^{-01}	3×10^{-01}
Sr-92		$8.2 \times 10^{+00}$	$1.1 \times 10^{+00}$	$1.2 \times 10^{+02}$	3.1×10^{-01}	$1 \times 10^{+00}$	3×10^{-01}
T(H-3)		—	$1.0 \times 10^{+03}$	$1.0 \times 10^{+03}$	—	$4 \times 10^{+01}$	$4 \times 10^{+01}$
Ta-178 (2.2 h)		$1.1 \times 10^{+00}$	$1.0 \times 10^{+03}$	$7.2 \times 10^{+02}$	8.2×10^{-01}	$1 \times 10^{+00}$	8×10^{-01}
Ta-179		$3.1 \times 10^{+01}$	$1.0 \times 10^{+03}$	$9.6 \times 10^{+01}$	$1.0 \times 10^{+03}$	$3 \times 10^{+01}$	$3 \times 10^{+01}$
Ta-182		8.7×10^{-01}	$1.3 \times 10^{+01}$	$5.1 \times 10^{+00}$	5.4×10^{-01}	9×10^{-01}	5×10^{-01}
Tb-157		$3.1 \times 10^{+02}$	$1.0 \times 10^{+03}$	$4.2 \times 10^{+01}$	$1.0 \times 10^{+03}$	$4 \times 10^{+01}$	$4 \times 10^{+01}$

TABLE I.2. (cont.)

Radio-nuclide	a - Q _F tabulated in place of Q _A	Q _A or Q _F (TBq)	Q _B (TBq)	Q _C (TBq)	Q _D or Q _E (TBq)	A ₁ (TBq)	A ₂ (TBq)
Tb-158		$1.4 \times 10^{+00}$	$1.6 \times 10^{+02}$	$1.1 \times 10^{+00}$	$1.8 \times 10^{+00}$	$1 \times 10^{+00}$	$1 \times 10^{+00}$
Tb-160		9.8×10^{-01}	$2.3 \times 10^{+00}$	$7.6 \times 10^{+00}$	5.8×10^{-01}	$1 \times 10^{+00}$	6×10^{-01}
Tc-95m		$1.5 \times 10^{+00}$	$1.0 \times 10^{+03}$	$5.7 \times 10^{+01}$	$1.2 \times 10^{+01}$	$2 \times 10^{+00}$	$2 \times 10^{+00}$
Tc-96		4.3×10^{-01}	$1.0 \times 10^{+03}$	$7.0 \times 10^{+01}$	$1.4 \times 10^{+02}$	4×10^{-01}	4×10^{-01}
Tc-96m		4.3×10^{-01}	$1.0 \times 10^{+03}$	$7.1 \times 10^{+01}$	$1.4 \times 10^{+02}$	4×10^{-01}	4×10^{-01}
Tc-97		$7.6 \times 10^{+01}$	$1.0 \times 10^{+03}$	Unlimited	Unlimited	Unlimited	Unlimited
Tc-97m		$8.6 \times 10^{+01}$	$1.0 \times 10^{+03}$	$1.6 \times 10^{+01}$	$1.4 \times 10^{+00}$	$4 \times 10^{+01}$	$1 \times 10^{+00}$
Tc-98		7.5×10^{-01}	$1.0 \times 10^{+03}$	Unlimited	6.8×10^{-01}	8×10^{-01}	7×10^{-01}
Tc-99		—	$1.0 \times 10^{+03}$	Unlimited	8.8×10^{-01}	$4 \times 10^{+01}$	9×10^{-01}
Tc-99m		$9.8 \times 10^{+00}$	$1.0 \times 10^{+03}$	$1.0 \times 10^{+03}$	$4.3 \times 10^{+00}$	$1 \times 10^{+01}$	$4 \times 10^{+00}$
Te-121		$1.8 \times 10^{+00}$	$1.0 \times 10^{+03}$	$1.3 \times 10^{+02}$	$1.0 \times 10^{+02}$	$2 \times 10^{+00}$	$2 \times 10^{+00}$
Te-121m		$5.1 \times 10^{+00}$	$1.0 \times 10^{+03}$	$1.2 \times 10^{+01}$	$2.5 \times 10^{+00}$	$5 \times 10^{+00}$	$3 \times 10^{+00}$
Te-123m		$7.7 \times 10^{+00}$	$1.0 \times 10^{+03}$	$1.3 \times 10^{+01}$	$1.2 \times 10^{+00}$	$8 \times 10^{+00}$	$1 \times 10^{+00}$
Te-125m		$2.0 \times 10^{+01}$	$1.0 \times 10^{+03}$	$1.5 \times 10^{+01}$	9.1×10^{-01}	$2 \times 10^{+01}$	9×10^{-01}
Te-127		$2.2 \times 10^{+02}$	$1.9 \times 10^{+01}$	$4.2 \times 10^{+02}$	6.6×10^{-01}	$2 \times 10^{+01}$	7×10^{-01}
Te-127m		$5.0 \times 10^{+01}$	$1.9 \times 10^{+01}$	$6.8 \times 10^{+00}$	5.0×10^{-01}	$2 \times 10^{+01}$	5×10^{-01}
Te-129		$1.7 \times 10^{+01}$	6.6×10^{-01}	$1.0 \times 10^{+03}$	6.1×10^{-01}	7×10^{-01}	6×10^{-01}
Te-129m		$1.3 \times 10^{+01}$	8.5×10^{-01}	$7.9 \times 10^{+00}$	4.4×10^{-01}	8×10^{-01}	4×10^{-01}
Te-131m		7.5×10^{-01}	$1.2 \times 10^{+00}$	$4.5 \times 10^{+01}$	4.9×10^{-01}	7×10^{-01}	5×10^{-01}
Te-132		4.9×10^{-01}	4.9×10^{-01}	$2.0 \times 10^{+01}$	4.2×10^{-01}	5×10^{-01}	4×10^{-01}
Th-227		$1.1 \times 10^{+01}$	$1.0 \times 10^{+03}$	5.2×10^{-03}	$4.7 \times 10^{+00}$	$1 \times 10^{+01}$	5×10^{-03}
Th-228		7.6×10^{-01}	5.3×10^{-01}	1.2×10^{-03}	2.7×10^{-01}	5×10^{-01}	1×10^{-03}
Th-229	a	$5.1 \times 10^{+00}$	$1.0 \times 10^{+03}$	5.1×10^{-04}	$1.8 \times 10^{+00}$	$5 \times 10^{+00}$	5×10^{-04}
Th-230	a	$1.2 \times 10^{+01}$	$1.0 \times 10^{+03}$	1.2×10^{-03}	Unlimited	$1 \times 10^{+01}$	1×10^{-03}
Th-231		$3.9 \times 10^{+01}$	$1.0 \times 10^{+03}$	1.6×10^{-02}	$1.2 \times 10^{+00}$	$4 \times 10^{+01}$	2×10^{-02}
Th-232		$1.2 \times 10^{+00}$	$1.0 \times 10^{+03}$	Unlimited	Unlimited	Unlimited	Unlimited
Th-234		$4.2 \times 10^{+01}$	3.0×10^{-01}	$6.8 \times 10^{+00}$	4.9×10^{-01}	3×10^{-01}	3×10^{-01}
Th(nat)		4.7×10^{-01}	2.7×10^{-01}	Unlimited	Unlimited	Unlimited	Unlimited
Ti-44		4.8×10^{-01}	6.1×10^{-01}	4.2×10^{-01}	6.2×10^{-01}	5×10^{-01}	4×10^{-01}
Tl-200		8.5×10^{-01}	$1.0 \times 10^{+03}$	$3.6 \times 10^{+02}$	$7.1 \times 10^{+00}$	9×10^{-01}	9×10^{-01}
Tl-201		$1.2 \times 10^{+01}$	$1.0 \times 10^{+03}$	$1.0 \times 10^{+03}$	$4.0 \times 10^{+00}$	$1 \times 10^{+01}$	$4 \times 10^{+00}$
Tl-202		$2.3 \times 10^{+00}$	$1.0 \times 10^{+03}$	$2.5 \times 10^{+02}$	$1.6 \times 10^{+01}$	$2 \times 10^{+00}$	$2 \times 10^{+00}$
Tl-204		$9.9 \times 10^{+02}$	$9.6 \times 10^{+00}$	$1.1 \times 10^{+02}$	6.9×10^{-01}	$1 \times 10^{+01}$	7×10^{-01}

TABLE I.2. (cont.)

Radio-nuclide	a - Q _F tabulated in place of Q _A	Q _A or Q _F (TBq)	Q _B (TBq)	Q _C (TBq)	Q _D or Q _E (TBq)	A ₁ (TBq)	A ₂ (TBq)
Tm-167		$7.4 \times 10^{+00}$	$1.0 \times 10^{+03}$	$4.5 \times 10^{+01}$	8.2×10^{-01}	$7 \times 10^{+00}$	8×10^{-01}
Tm-170		$2.0 \times 10^{+02}$	$2.6 \times 10^{+00}$	$7.6 \times 10^{+00}$	6.1×10^{-01}	$3 \times 10^{+00}$	6×10^{-01}
Tm-171		$1.0 \times 10^{+03}$	$1.0 \times 10^{+03}$	$3.8 \times 10^{+01}$	$1.0 \times 10^{+02}$	$4 \times 10^{+01}$	$4 \times 10^{+01}$
U-230 (F)		$5.2 \times 10^{+01}$	$1.0 \times 10^{+03}$	1.4×10^{-01}	$3.1 \times 10^{+00}$	$4 \times 10^{+01}$	1×10^{-01}
U-230 (M)	a	$3.8 \times 10^{+01}$	$1.0 \times 10^{+03}$	3.8×10^{-03}	$3.1 \times 10^{+00}$	$4 \times 10^{+01}$	4×10^{-03}
U-230 (S)	a	$3.3 \times 10^{+01}$	$1.0 \times 10^{+03}$	3.3×10^{-03}	$3.1 \times 10^{+00}$	$3 \times 10^{+01}$	3×10^{-03}
U-232 (F)	a	$1.4 \times 10^{+02}$	$1.0 \times 10^{+03}$	1.4×10^{-02}	$1.8 \times 10^{+02}$	$4 \times 10^{+01}$	1×10^{-02}
U-232 (M)	a	$7.1 \times 10^{+01}$	$1.0 \times 10^{+03}$	7.1×10^{-03}	$1.8 \times 10^{+02}$	$4 \times 10^{+01}$	7×10^{-03}
U-232 (S)	a	$1.4 \times 10^{+01}$	$1.0 \times 10^{+03}$	1.4×10^{-03}	$1.8 \times 10^{+02}$	$1 \times 10^{+01}$	1×10^{-03}
U-233 (F)		$8.0 \times 10^{+02}$	$1.0 \times 10^{+03}$	8.8×10^{-02}	Unlimited	$4 \times 10^{+01}$	9×10^{-02}
U-233 (M)	a	$1.6 \times 10^{+02}$	$1.0 \times 10^{+03}$	1.6×10^{-02}	Unlimited	$4 \times 10^{+01}$	2×10^{-02}
U-233 (S)	a	$5.7 \times 10^{+01}$	$1.0 \times 10^{+03}$	5.7×10^{-03}	Unlimited	$4 \times 10^{+01}$	6×10^{-03}
U-234 (F)		$6.0 \times 10^{+02}$	$1.0 \times 10^{+03}$	9.1×10^{-02}	Unlimited	$4 \times 10^{+01}$	9×10^{-02}
U-234 (M)	a	$1.6 \times 10^{+02}$	$1.0 \times 10^{+03}$	1.6×10^{-02}	Unlimited	$4 \times 10^{+01}$	2×10^{-02}
U-234 (S)	a	$5.9 \times 10^{+01}$	$1.0 \times 10^{+03}$	5.9×10^{-03}	Unlimited	$4 \times 10^{+01}$	6×10^{-03}
U-235 (F)		$6.4 \times 10^{+00}$	$1.0 \times 10^{+03}$	Unlimited	Unlimited	Unlimited	Unlimited
U-235 (M)		$6.4 \times 10^{+00}$	$1.0 \times 10^{+03}$	Unlimited	Unlimited	Unlimited	Unlimited
U-235 (S)		$6.4 \times 10^{+00}$	$1.0 \times 10^{+03}$	Unlimited	Unlimited	Unlimited	Unlimited
U-236 (F)		$6.6 \times 10^{+02}$	$1.0 \times 10^{+03}$	Unlimited	Unlimited	Unlimited	Unlimited
U-236 (M)	a	$1.7 \times 10^{+02}$	$1.0 \times 10^{+03}$	1.7×10^{-02}	Unlimited	$4 \times 10^{+01}$	2×10^{-02}
U-236 (S)	a	$6.3 \times 10^{+01}$	$1.0 \times 10^{+03}$	6.3×10^{-03}	Unlimited	$4 \times 10^{+01}$	6×10^{-03}
U-238 (F)		$7.5 \times 10^{+02}$	$1.0 \times 10^{+03}$	Unlimited	Unlimited	Unlimited	Unlimited
U-238 (M)	a	$1.9 \times 10^{+02}$	$1.0 \times 10^{+03}$	Unlimited	Unlimited	Unlimited	Unlimited
U-238 (S)	a	$6.8 \times 10^{+01}$	$1.0 \times 10^{+03}$	Unlimited	Unlimited	Unlimited	Unlimited
U (nat)		6.4×10^{-01}	1.3×10^{-01}	Unlimited	Unlimited	Unlimited	Unlimited
U (<20% enr.)		—	—	—	—	Unlimited	Unlimited
U (dep)		$4.7 \times 10^{+01}$	3.3×10^{-01}	Unlimited	Unlimited	Unlimited	Unlimited
V-48		3.8×10^{-01}	$3.0 \times 10^{+00}$	$2.2 \times 10^{+01}$	$1.1 \times 10^{+00}$	4×10^{-01}	4×10^{-01}
V-49		$1.0 \times 10^{+03}$	$1.0 \times 10^{+03}$	$1.0 \times 10^{+03}$	$1.0 \times 10^{+03}$	$4 \times 10^{+01}$	$4 \times 10^{+01}$
W-178		$8.8 \times 10^{+00}$	$1.0 \times 10^{+03}$	$6.4 \times 10^{+02}$	$4.6 \times 10^{+00}$	$9 \times 10^{+00}$	$5 \times 10^{+00}$
W-181		$2.6 \times 10^{+01}$	$1.0 \times 10^{+03}$	$1.0 \times 10^{+03}$	$5.3 \times 10^{+02}$	$3 \times 10^{+01}$	$3 \times 10^{+01}$
W-185		$1.0 \times 10^{+03}$	$1.0 \times 10^{+03}$	$3.6 \times 10^{+02}$	8.1×10^{-01}	$4 \times 10^{+01}$	8×10^{-01}
W-187		$2.2 \times 10^{+00}$	$2.1 \times 10^{+00}$	$2.5 \times 10^{+02}$	6.2×10^{-01}	$2 \times 10^{+00}$	6×10^{-01}
W-188		$2.0 \times 10^{+01}$	3.7×10^{-01}	$4.4 \times 10^{+01}$	3.5×10^{-01}	4×10^{-01}	3×10^{-01}

TABLE I.2. (cont.)

Radio-nuclide	$a - Q_F$ tabulated in place of Q_A	Q_A or Q_F (TBq)	Q_B (TBq)	Q_C (TBq)	Q_D or Q_E (TBq)	A_1 (TBq)	A_2 (TBq)
Xe-122		$1.1 \times 10^{+00}$	4.0×10^{-01}	—	$8.8 \times 10^{+00}$	4×10^{-01}	4×10^{-01}
Xe-123		$1.8 \times 10^{+00}$	$1.0 \times 10^{+01}$	—	6.8×10^{-01}	$2 \times 10^{+00}$	7×10^{-01}
Xe-127		$3.9 \times 10^{+00}$	$1.0 \times 10^{+03}$	—	$1.7 \times 10^{+00}$	$4 \times 10^{+00}$	$2 \times 10^{+00}$
Xe-131m		$3.8 \times 10^{+01}$	$1.0 \times 10^{+03}$	—	$4.0 \times 10^{+01}$	$4 \times 10^{+01}$	$4 \times 10^{+01}$
Xe-133		$2.1 \times 10^{+01}$	$1.0 \times 10^{+03}$	—	$1.5 \times 10^{+01}$	$2 \times 10^{+01}$	$1 \times 10^{+01}$
Xe-135		$4.5 \times 10^{+00}$	$3.5 \times 10^{+00}$	—	$1.8 \times 10^{+00}$	$3 \times 10^{+00}$	$2 \times 10^{+00}$
Y-87		$1.4 \times 10^{+00}$	$1.0 \times 10^{+03}$	$1.2 \times 10^{+02}$	$3.2 \times 10^{+00}$	$1 \times 10^{+00}$	$1 \times 10^{+00}$
Y-88		4.3×10^{-01}	$1.0 \times 10^{+03}$	$1.2 \times 10^{+01}$	$2.2 \times 10^{+02}$	4×10^{-01}	4×10^{-01}
Y-90		$1.0 \times 10^{+03}$	3.2×10^{-01}	$3.3 \times 10^{+01}$	5.9×10^{-01}	3×10^{-01}	3×10^{-01}
Y-91		$3.1 \times 10^{+02}$	5.9×10^{-01}	$6.0 \times 10^{+00}$	6.1×10^{-01}	6×10^{-01}	6×10^{-01}
Y-91m		$2.0 \times 10^{+00}$	$1.0 \times 10^{+03}$	$1.0 \times 10^{+03}$	$1.2 \times 10^{+01}$	$2 \times 10^{+00}$	$2 \times 10^{+00}$
Y-92		$4.4 \times 10^{+00}$	2.2×10^{-01}	$2.5 \times 10^{+02}$	5.6×10^{-01}	2×10^{-01}	2×10^{-01}
Y-93		$1.3 \times 10^{+01}$	2.6×10^{-01}	$1.2 \times 10^{+02}$	5.8×10^{-01}	3×10^{-01}	3×10^{-01}
Yb-169		$3.5 \times 10^{+00}$	$1.0 \times 10^{+03}$	$1.8 \times 10^{+01}$	$1.0 \times 10^{+00}$	$4 \times 10^{+00}$	$1 \times 10^{+00}$
Yb-175		$2.7 \times 10^{+01}$	$1.0 \times 10^{+03}$	$7.1 \times 10^{+01}$	$4.2 \times 10^{+01}$	$2 \times 10^{+00}$	$2 \times 10^{+00}$
Zn-69		$1.0 \times 10^{+03}$	$3.2 \times 10^{+00}$	$1.0 \times 10^{+03}$	6.2×10^{-01}	$3 \times 10^{+00}$	6×10^{-01}
Zn-69m		$3.4 \times 10^{+00}$	$4.0 \times 10^{+00}$	$1.7 \times 10^{+02}$	5.9×10^{-01}	$3 \times 10^{+00}$	6×10^{-01}
Zr-88		$2.6 \times 10^{+00}$	$1.0 \times 10^{+03}$	$1.4 \times 10^{+01}$	$2.1 \times 10^{+01}$	$3 \times 10^{+00}$	$3 \times 10^{+00}$
Zr-93		—	$1.0 \times 10^{+03}$	Unlimited	Unlimited	Unlimited	Unlimited
Zr-95		$1.8 \times 10^{+00}$	$4.5 \times 10^{+02}$	$9.1 \times 10^{+00}$	8.5×10^{-01}	$2 \times 10^{+00}$	8×10^{-01}
Zr-97		9.2×10^{-01}	3.7×10^{-01}	$5.0 \times 10^{+01}$	5.6×10^{-01}	4×10^{-01}	4×10^{-01}

Consideration of physical and chemical properties

I.82. A further factor considered by the Special Working Group meeting was the need to apply additional limits for materials whose physical properties might render invalid the assumptions used in deriving the Q values discussed above. Such considerations are relevant to materials that may become volatile at the elevated temperatures which could occur in a fire, or which may be transported as very finely divided powders, and especially for the model used to evaluate the Q_C values. However, on balance it was considered that only in the most extreme circumstances would the assumed intake factor of 10^{-6} be exceeded and that special modification of the Q_C model was unnecessary for these materials.

I.83. As in the case of the 1985 edition of the Regulations, no consideration was given to the chemical form or chemical properties of radionuclides. However, in the determination of Q_C values the most restrictive of the dose coefficients recommended by the ICRP [I.8] were used.

Multiple exposure pathways

I.84. Following the 1985 edition of the Regulations, the application of the Q system as described here treats the derivation of each Q value, and hence each potential exposure pathway, separately. In general this will result in compliance with the dosimetric criteria defined earlier, provided that the doses incurred by persons exposed near a damaged package are dominated by one pathway. However, if two or more Q values closely approach each other this will not necessarily be the case. For example, in the case of a radionuclide transported as a special form radioactive material for which $Q_A \approx Q_B$, the effective dose and skin dose to an exposed person could approach 50 mSv and 0.5 Sv, respectively, on the basis of the Q system models. Examination of Table I.2 shows that this consideration applies only to a relatively small number of radionuclides, and for this reason the independent treatment of exposure pathways is retained within the Q system.

Mixtures of radionuclides

I.85. Finally, it is necessary to consider the package contents limits for mixtures of radionuclides, including the special case of mixed fission products. For mixtures whose identities and activities are known it is necessary to show that:

$$\sum_i \frac{B(i)}{A_1(i)} + \sum_j \frac{C(j)}{A_2(j)} \leq 1$$

where

B(i) is the activity of radionuclide i as special form material,

A₁(i) is the A₁ value for radionuclide i,

C(j) is the activity of radionuclide j as other than special form material, and

A₂(j) is the A₂ value for radionuclide j.

1.86. Alternatively, values for mixtures may be determined as follows:

$$X_m \text{ for mixture} = \frac{1}{\sum_i \frac{f(i)}{X(i)}}$$

where

f(i) is the fraction of activity of radionuclide i in the mixture,

X(i) is the appropriate value of A₁ or A₂ for the radionuclide, and

X_m is the derived value of A₁ or A₂, for the mixture.

DECAY CHAINS USED IN THE Q SYSTEM

1.87. Table I.3 lists the various decay chains that were used in developing A₁ and A₂ values with the Q system as described in paras I.54–I.56.

CONCLUSIONS

1.88. The Q system described here represents an updating of the original A₁/A₂ system used in the 1985 edition of the Regulations for the determination of Type A package contents and other limits. It incorporates the latest recommendations of the ICRP and by explicitly identifying the dosimetric considerations underlying the derivation of these limits provides a firm and defensible basis for the Regulations.

1.89. The Q system now has the following features:

- (1) The radiological criteria and exposure assumptions used in the 1985 edition of the Regulations have been reviewed and retained;
- (2) The effective dose quantity of ICRP Publication 60 [I.8] has been adopted;
- (3) The evaluation of the external dose from photons and beta particles has been rigorously revised; and
- (4) The evaluation of inhalation intakes is now in terms of the effective dose and based on the dose coefficients from the Basic Safety Standards [I.10] and ICRP Publication 68 [I.9].

Further review based upon future developments is not precluded.

TABLE I.3. DECAY CHAINS USED IN THE Q SYSTEM

Parent radionuclide	Daughter radionuclides
12 Mg 28(*)	13 Al 28
18 Ar 42(*)	19 K 42
20 Ca 47	21 Sc 47
22 Ti 44(*)	21 Sc 44
26 Fe 52(*)	25 Mn 52m
26 Fe 60	27 Co 60m
30 Zn 69m(*)	30 Zn 69
32 Ge 68(*)	31 Ga 68
37 Rb 83	36 Kr 83m
38 Sr 82(*)	37 Rb 82
38 Sr 90(*)	39 Y 90
38 Sr 91	39 Y 91m
38 Sr 92(*)	39 Y 92
39 Y 87	38 Sr 87m
40 Zr 95	41 Nb 95m
40 Zr 97	41 Nb 97m, 41 Nb 97
42 Mo 99	43 Tc 99m
43 Tc 95m	43 Tc 95
43 Tc 96m(*)	43 Tc 96
44 Ru 103	45 Rh 103m
44 Ru 106(*)	45 Rh 106
46 Pd 103	45 Rh 103m
47 Ag 108m	47 Ag 108
47 Ag 110m	47 Ag 110
48 Cd 115	49 In 115m
49 In 114m(*)	49 In 114
50 Sn 113	49 In 113m
50 Sn 121m	50 Sn 121
50 Sn 126	51 Sb 126m
52 Te 118	51 Sb 118
52 Te 127m	52 Te 127
52 Te 129m	52 Te 129
52 Te 131m	52 Te 131
52 Te 132	53 I 132
53 I 135	51 Xe 135m
54 Xe 122	53 I 122
55 Cs 137	56 Ba 137m
56 Ba 131	55 Cs 131
56 Ba 140	57 La 140
58 Ce 144	59 Pr 144m, 59 Pr 144

TABLE I.3. (cont.)

Parent radionuclide	Daughter radionuclides
61 Pm 148m	61 Pm 148
64 Gd 146	63 Eu 146
66 Dy 166	67 Ho 166
72 Hf 172	71 Lu 172
74 W 178	73 Ta 178
74 W 188	75 Re 188
75 Re 189	76 Os 189m
76 Os 194	77 Ir 194
77 Ir 189	76 Os 189m
78 Pt 188	77 Ir 188
80 Hg 194	79 Au 194
80 Hg 195m	80 Hg 195
82 Pb 210	83 Bi 210
82 Pb 212	83 Bi 212, 81 Tl 208, 84 Po 212
83 Bi 210m	81 Tl 206
83 Bi 212	81 Tl 208, 84 Po 212
85 At 211	84 Po 211
86 Rn 222	84 Po 218, 82 Pb 214, 85 At 218, 83 Bi 214, 84 Po 214
88 Ra 223	86 Rn 219, 84 Po 215, 82 Pb 211, 83 Bi 211, 84 Po 211, 81 Tl 207
88 Ra 224	86 Rn 220, 84 Po 216, 82 Pb 212, 83 Bi 212, 81 Tl 208, 84 Po 212
88 Ra 225	89 Ac 225, 87 Fr 221, 85 At 217, 83 Bi 213, 81 Tl 209, 84 Po 213, 82 Pb 209
88 Ra 226	86 Rn 222, 84 Po 218, 82 Pb 214, 85 At 218, 83 Bi 214, 84 Po 214
88 Ra 228	89 Ac 228
89 Ac 225	87 Fr 221, 85 At 217, 83 Bi 213, 81 Tl 209, 84 Po 213, 82 Pb 209
89 Ac 227	87 Fr 223
90 Th 228	88 Ra 224, 86 Rn 220, 84 Po 216, 82 Pb 212, 83 Bi 212, 81 Tl 208, 84 Po 212
90 Th 234	91 Pa 234m, 91 Pa 234
91 Pa 230	89 Ac 226, 90 Th 226, 87 Fr 222, 88 Ra 222, 86 Rn 218, 84 Po 214
92 U 230	90 Th 226, 88 Ra 222, 86 Rn 218, 84 Po 214
92 U 235	90 Th 231
94 Pu 241	92 U 237
94 Pu 244	92 U 240, 93 Np 240m
95 Am 242m	95 Am 242, 93 Np 238

TABLE I.3. (cont.)

Parent radionuclide	Daughter radionuclides
95 Am 243	93 Np 239
96 Cm 247	94 Pu 243
97 Bk 249	95 Am 245
98 Cf 253	96 Cm 249

REFERENCES TO APPENDIX I

- [I.1] INTERNATIONAL ATOMIC ENERGY AGENCY, International Studies on Certain Aspects of the Safe Transport of Radioactive Materials, 1980–1985, IAEA-TECDOC-375, IAEA, Vienna (1986).
- [I.2] GOLDFINCH, E.P., MACDONALD, H.F., Dosimetric aspects of permitted activity leakage rates for Type B packages for the transport of radioactive materials, *Radiat. Prot. Dosim.* **2** (1982) 75.
- [I.3] MACDONALD, H.F., GOLDFINCH, E.P., “An alternative approach to the A_1/A_2 system for determining package contents limits and permitted releases of radioactivity from transport packages”, Packaging and Transportation of Radioactive Materials, PATRAM 80 (Proc. Symp. Berlin, 1980), Bundesanstalt für Materialprüfung, Berlin (1980).
- [I.4] MACDONALD, H.F., GOLDFINCH, E.P., *Radiat. Prot. Dosim.* **1** (1981) 29.
- [I.5] MACDONALD, H.F., GOLDFINCH, E.P., *ibid.*, p. 199.
- [I.6] GOLDFINCH, E.P., MACDONALD, H.F., “A review of some radiological aspects of the IAEA Regulations for the Safe Transport of Radioactive Materials”, Radiological Protection —Advances in Theory and Practice (Proc. Symp. Inverness, 1982), Society for Radiological Protection, Berkeley, UK (1982).
- [I.7] GOLDFINCH, E.P., MACDONALD, H.F., “IAEA Regulations for the Safe Transport of Radioactive Materials: Revised A_1 and A_2 values”, Packaging and Transportation of Radioactive Materials, PATRAM 83 (Proc. Symp. New Orleans, 1983), Oak Ridge National Laboratory, Oak Ridge, TN (1983).
- [I.8] INTERNATIONAL COMMISSION ON RADIOLOGICAL PROTECTION, 1990 Recommendations of the ICRP, ICRP Publication 60, Pergamon Press, Oxford and New York (1991).
- [I.9] INTERNATIONAL COMMISSION ON RADIOLOGICAL PROTECTION, Dose Coefficients for Intakes of Radionuclides by Workers, ICRP Publication No. 68, Pergamon Press, Oxford and New York (1995).
- [I.10] FOOD AND AGRICULTURE ORGANIZATION OF THE UNITED NATIONS, INTERNATIONAL ATOMIC ENERGY AGENCY, INTERNATIONAL LABOUR ORGANISATION, OECD NUCLEAR ENERGY AGENCY, PAN AMERICAN HEALTH ORGANIZATION, WORLD HEALTH ORGANIZATION, International

Basic Safety Standards for Protection against Ionizing Radiation and for the Safety of Radiation Sources, Safety Series No. 115, IAEA, Vienna (1996).

- [I.11] INTERNATIONAL COMMISSION ON RADIOLOGICAL PROTECTION, Task Group on Dose Calculations — Energy and Intensity Data for Emissions Accompanying Radionuclide Transformations, ICRP Publication 38, Pergamon Press, Oxford and New York (1984).
- [I.12] INTERNATIONAL COMMISSION ON RADIOLOGICAL PROTECTION, Data for Use in Protection against External Radiation, ICRP Publication 51, Pergamon Press, Oxford and New York (1987).
- [I.13] ECKERMAN, K.F., WESTFALL, R.J., RYMAN, J.C., CRISTY, M., Nuclear Decay Data Files of the Dosimetry Research Group, Rep. ORNL/TM-12350, Oak Ridge National Laboratory, Oak Ridge, TN (1993).
- [I.14] CROSS, W.G., ING, H., FREEDMAN, N.O., WONG, P.J., Table of beta-ray dose distributions in an infinite water medium, *Health Phys.* **63** (1992) 2.
- [I.15] CROSS, W.G., ING, H., FREEDMAN, N.O., MAINVILLE, J., Tables of Beta-Ray Dose Distributions in Water, Air, and Other Media, Rep. AECL-7617, Atomic Energy of Canada Ltd., Chalk River, Ontario (1982).
- [I.16] INTERNATIONAL COMMISSION ON RADIOLOGICAL PROTECTION, ICRP Publication 26, Pergamon Press, Oxford and New York (1977).
- [I.17] CROSS, W.G., ING, H., FREEDMAN, N.O., MAINVILLE, J., Tables of Beta-Ray Dose Distributions in Water, Air, and Other Media, Rep. AECL-2793, Atomic Energy of Canada Ltd., Chalk River, Ontario (1967).
- [I.18] BAILEY, M.R., BETA: A Computer Program for Calculating Beta Dose Rates from Point and Plane Sources, Rep. RD/B/N2763, Central Electricity Generating Board, London (1973).
- [I.19] INTERNATIONAL COMMISSION ON RADIOLOGICAL PROTECTION, Limits for Intakes of Radionuclides by Workers, Publication 30, Parts 1–3, Pergamon Press, Oxford and New York (1980).
- [I.20] LOHMANN, D.H., “Transport of radioactive materials: A review of damage to packages from the radiochemical centre during transport”, *Packaging and Transportation of Radioactive Materials*, PATRAM 80 (Proc. Symp. Berlin, 1980), Bundesanstalt für Materialprüfung, Berlin (1980).
- [I.21] HADJANTONION, A., ARMIRIOTIS, J., ZANNOS, A., “The performance of Type A packaging under air crash and fire accident conditions”, *ibid.*
- [I.22] TAYLOR, C.B.G., “Radioisotope packages in crush and fire”, *ibid.*
- [I.23] STEWART, K., Principal characteristics of radioactive contaminants which may appear in the atmosphere, *Progress in Nuclear Energy, Series 12, Health Physics, Vol. 2*, Pergamon Press, Oxford and New York (1969).
- [I.24] WEHNER, G., “The importance of reportable events in public acceptance”, *Packaging and Transportation of Radioactive Materials*, PATRAM 83 (Proc. Symp. New Orleans, 1983), Oak Ridge National Laboratory, Oak Ridge, TN (1983).
- [I.25] BRYANT, P.M., Methods of Estimation of the Dispersion of Windborne Material and Data to Assist in their Application, Rep. AHSB(RP)R42, UKAEA, Berkeley, UK (1964).
- [I.26] DUNSTER, H.J., Maximum Permissible Levels of Skin Contamination, Rep. AHSB (RP)R78, UKAEA, Harwell (1967).

- [I.27] CROSS, W.G., FREEDMAN, N.O., WONG, P.Y., Beta ray dose distributions from skin contamination, *Radiat. Prot. Dosim.* **40** 3 (1992) 149–168.
- [I.28] UNITED STATES ENVIRONMENTAL PROTECTION AGENCY, External Exposure to Radionuclides in Air, Water and Soil, Federal Guidance Report No. 12, USEPA, Washington, DC (1993).
- [I.29] INTERNATIONAL COMMISSION ON RADIOLOGICAL PROTECTION, Data for Protection against Ionizing Radiation from External Sources: Supplement to ICRP Publication 15, ICRP Publication 21, Pergamon Press, Oxford and New York (1973).
- [I.30] FAIRBAIRN, A., MORLEY, F., KOLB, W., “The classification of radionuclides for transport purposes”, *The Safe Transport of Radioactive Materials* (GIBSON, R., Ed.), Pergamon Press, Oxford and New York (1966) 44–46.
- [I.31] INTERNATIONAL COMMISSION ON RADIOLOGICAL PROTECTION, Limits for Inhalation of Radon Daughters by Workers, ICRP Publication 32, Pergamon Press, Oxford and New York (1981).
- [I.32] AMERICAN SOCIETY FOR TESTING AND MATERIALS, Standard Specification for Uranium Hexafluoride Enriched to Less than 5% U-235, ASTM C996-90, ASTM, Philadelphia, PA (1991).
- [I.33] INTERNATIONAL COMMISSION ON RADIOLOGICAL PROTECTION, Recommendations of the International Commission on Radiological Protection (as amended 1959 and revised 1962), ICRP Publication 6, Pergamon Press, Oxford and New York (1964).
- [I.34] MACDONALD, H.F., Radiological Limits in the Transport of Irradiated Nuclear Fuels, Rep. TPRD/B/0388/N84, Central Electricity Generating Board, Berkeley, UK (1984).
- [I.35] MACDONALD, H.F., “Individual and collective doses arising in the transport of irradiated nuclear fuels”, *Packaging and Transportation of Radioactive Materials*, PATRAM 80 (Proc. Symp. Berlin, 1980), Bundesanstalt für Materialprüfung, Berlin (1980).
- [I.36] LAUTERBACH, U., “Radiation level for low specific activity materials in compact stacks, packaging and transportation of radioactive materials”, *ibid.*

Appendix II

HALF-LIFE AND SPECIFIC ACTIVITY OF RADIONUCLIDES, DOSE AND DOSE RATE COEFFICIENTS OF RADIONUCLIDES AND SPECIFIC ACTIVITY

II.1. Table II.1 provides a listing of the half-life and the specific activity of each radionuclide calculated using the equation shown in para. 240.2 (see Ref. [II.1]). As specified in para. 240 of the Regulations, the specific activity of a radionuclide is the “activity per unit mass of that nuclide”, whereas the specific activity of a material “shall mean the activity per unit mass or volume of the material in which the radionuclides are essentially uniformly distributed”. The specific activity values listed in Table II.1 relate to the radionuclide and not to the material.

II.2. Table II.2 provides a listing of the dose and dose rate coefficients of each radionuclide.

II.3. Table II.3 provides the specific activity of uranium for various levels of enrichment. These figures for uranium include the activity of U-234, which is concentrated during the enrichment process.

TABLE II.1. HALF-LIFE AND SPECIFIC ACTIVITY OF RADIONUCLIDES

Radionuclide	Element and atomic number	Half-life		Specific activity (Bq/g)
		$T_{1/2}$ (a,d,h,min)	$T_{1/2}$ (s)	
Ac-225	Actinium (89)	10 d	8.640×10^5	2.150×10^{15}
Ac-227		21.773 a	6.866×10^8	2.682×10^{12}
Ac-228		6.13 h	2.207×10^4	8.308×10^{16}
Ag-105	Silver (47)	41 d	3.542×10^6	1.124×10^{15}
Ag-108m		127 a	4.005×10^9	9.664×10^{11}
Ag-110m		249.9 d	2.159×10^7	1.760×10^{14}
Ag-111		7.45 d	6.437×10^5	5.850×10^{15}
Al-26	Aluminium (13)	7.16×10^5 a	2.258×10^{13}	7.120×10^8
Am-241	Americium (95)	432.2 a	1.363×10^{10}	1.273×10^{11}
Am-242m		152 a	4.793×10^9	3.603×10^{11}
Am-243		7380 a	2.327×10^{11}	7.391×10^9

TABLE II.1. (cont.)

Radionuclide	Element and atomic number	Half-life		Specific activity (Bq/g)
		$T_{1/2}$ (a,d,h,min)	$T_{1/2}$ (s)	
Ar-37	Argon (18)	35.02 d	3.026×10^6	3.734×10^{15}
Ar-39		269 a	8.483×10^9	1.263×10^{12}
Ar-41		1.827 h	6.577×10^3	1.550×10^{18}
As-72	Arsenic (33)	26 h	9.360×10^4	6.203×10^{16}
As-73		80.3 d	6.938×10^6	8.253×10^{14}
As-74		17.76 d	1.534×10^6	3.681×10^{15}
As-76		26.32 h	9.475×10^4	5.805×10^{16}
As-77		38.8 h	1.397×10^5	3.886×10^{16}
At-211	Astatine (85)	7.214 h	2.597×10^4	7.628×10^{16}
Au-193	Gold (79)	17.65 h	6.354×10^4	3.409×10^{16}
Au-194		39.5 h	1.422×10^5	1.515×10^{16}
Au-195		183 d	1.581×10^7	1.356×10^{14}
Au-198		2.696 d	2.329×10^5	9.063×10^{15}
Au-199		3.139 d	2.712×10^5	7.745×10^{15}
Ba-131	Barium (56)	11.8 d	1.020×10^6	3.130×10^{15}
Ba-133		10.74 a	3.387×10^8	9.279×10^{12}
Ba-133m		38.9 h	1.400×10^5	2.244×10^{16}
Ba-140		12.74 d	1.101×10^6	2.712×10^{15}
Be-7	Beryllium (4)	53.3 d	4.605×10^6	1.297×10^{16}
Be-10		1.6×10^6 a	5.046×10^{13}	8.284×10^8
Bi-205	Bismuth (83)	15.31 d	1.323×10^6	1.541×10^{15}
Bi-206		6.243 d	5.394×10^5	3.762×10^{15}
Bi-207		38 a	1.198×10^9	1.685×10^{12}
Bi-210		5.012 d	4.330×10^5	4.597×10^{15}
Bi-210m		3.0×10^6 a	9.461×10^{13}	2.104×10^7
Bi-212		60.55 min	3.633×10^3	5.427×10^{17}
Bk-247	Berkelium (97)	1380 a	4.352×10^{10}	3.889×10^{10}
Bk-249		320 d	2.765×10^7	6.072×10^{13}
Br-76	Bromine (35)	16.2 h	5.832×10^4	9.431×10^{16}
Br-77		56 h	2.016×10^5	2.693×10^{16}
Br-82		35.3 h	1.271×10^5	4.011×10^{16}

TABLE II.1. (cont.)

Radionuclide	Element and atomic number	Half-life		Specific activity (Bq/g)
		$T_{1/2}$ (a,d,h,min)	$T_{1/2}$ (s)	
C-11	Carbon (6)	20.38 min	1.223×10^3	3.108×10^{19}
C-14		5730 a	1.807×10^{11}	1.652×10^{11}
Ca-41	Calcium (20)	1.4×10^5 a	4.415×10^{12}	2.309×10^9
Ca-45		163 d	1.408×10^7	6.596×10^{14}
Ca-47		4.53 d	3.914×10^5	2.272×10^{16}
Cd-109	Cadmium (48)	464 d	4.009×10^7	9.566×10^{13}
Cd-113m		13.6 a	4.289×10^8	8.625×10^{12}
Cd-115		53.46 h	1.925×10^5	1.889×10^{16}
Cd-115m		44.6 d	3.853×10^6	9.433×10^{14}
Ce-139	Cerium (58)	137.66 d	1.189×10^7	2.528×10^{14}
Ce-141		32.501 d	2.808×10^6	1.056×10^{15}
Ce-143		33 h	1.188×10^5	2.461×10^{16}
Ce-144		284.3 d	2.456×10^7	1.182×10^{14}
Cf-248	Californium (98)	333.5 d	2.881×10^7	5.849×10^{13}
Cf-249		350.6 a	1.106×10^{10}	1.518×10^{11}
Cf-250		13.08 a	4.125×10^8	4.053×10^{12}
Cf-251		898 a	2.832×10^{10}	5.881×10^{10}
Cf-252		2.638 a	8.319×10^7	1.994×10^{13}
Cf-253		17.81 d	1.539×10^6	1.074×10^{15}
Cf-254		60.5 d	5.227×10^6	3.148×10^{14}
Cl-36		Chlorine (17)	3.01×10^5 a	9.492×10^{12}
Cl-38	37.21 min		2.233×10^3	4.927×10^{18}
Cm-240	Curium (96)	27 d	2.333×10^6	7.466×10^{14}
Cm-241		32.8 d	2.834×10^6	6.120×10^{14}
Cm-242		162.8 d	1.407×10^7	1.228×10^{14}
Cm-243		28.5 a	8.988×10^8	1.914×10^{12}
Cm-244		18.11 a	5.711×10^8	3.000×10^{12}
Cm-245		8500 a	2.681×10^{11}	6.365×10^9
Cm-246		4730 a	1.492×10^{11}	1.139×10^{10}
Cm-247		1.56×10^7 a	4.920×10^{14}	3.440×10^6
Cm-248		3.39×10^5 a	1.069×10^{13}	1.577×10^8

TABLE II.1. (cont.)

Radionuclide	Element and atomic number	Half-life		Specific activity (Bq/g)
		$T_{1/2}$ (a,d,h,min)	$T_{1/2}$ (s)	
Co-55	Cobalt (27)	17.54 h	6.314×10^4	1.204×10^{17}
Co-56		78.76 d	6.805×10^6	1.097×10^{15}
Co-57		270.9 d	2.341×10^7	3.133×10^{14}
Co-58		70.8 d	6.117×10^6	1.178×10^{15}
Co-58m		9.15 h	3.294×10^4	2.188×10^{17}
Co-60		5.271 a	1.662×10^8	4.191×10^{13}
Cr-51		Chromium (24)	27.704 d	2.394×10^6
Cs-129	Caesium (55)	32.06 h	1.154×10^5	2.808×10^{16}
Cs-131		9.69 d	8.372×10^5	3.811×10^{15}
Cs-132		6.475 d	5.594×10^5	5.660×10^{15}
Cs-134		2.062 a	6.503×10^7	4.797×10^{13}
Cs-134m		2.9 h	1.044×10^4	2.988×10^{17}
Cs-135		2.3×10^6 a	7.253×10^{13}	4.269×10^7
Cs-136		13.1 d	1.132×10^6	2.716×10^{15}
Cs-137		30 a	9.461×10^8	3.225×10^{12}
Cu-64		Copper (29)	12.701 h	4.572×10^4
Cu-67	61.86 h		2.227×10^5	2.801×10^{16}
Dy-159	Dysprosium (66)	144.4 d	1.248×10^7	2.107×10^{14}
Dy-165		2.334 h	8.402×10^3	3.015×10^{17}
Dy-166		81.6 h	2.938×10^5	8.572×10^{15}
Er-169	Erbium (68)	9.3 d	8.035×10^5	3.078×10^{15}
Er-171		7.52 h	2.707×10^4	9.029×10^{16}
Eu-147	Europium (63)	24 d	2.074×10^6	1.371×10^{15}
Eu-148		54.5 d	4.709×10^6	5.998×10^{14}
Eu-149		93.1 d	8.044×10^6	3.488×10^{14}
Eu-150 (short-lived)		12.62 h	4.543×10^4	6.134×10^{16}
Eu-150 (long-lived)		34.2 a	1.079×10^9	2.584×10^{12}
Eu-152		13.33 a	4.204×10^8	6.542×10^{12}
Eu-152m		9.32 h	3.355×10^4	8.196×10^{16}
Eu-154		8.8 a	2.775×10^8	9.781×10^{12}
Eu-155		4.96 a	1.564×10^8	1.724×10^{13}
Eu-156		15.19 d	1.312×10^6	2.042×10^{15}

TABLE II.1. (cont.)

Radionuclide	Element and atomic number	Half-life		Specific activity (Bq/g)
		$T_{1/2}$ (a,d,h,min)	$T_{1/2}$ (s)	
F-18	Fluorine (9)	109.77 min	6.586×10^3	3.526×10^{18}
Fe-52	Iron (26)	8.275 h	2.979×10^4	2.698×10^{17}
Fe-55		2.7 a	8.515×10^7	8.926×10^{13}
Fe-59		44.529 d	3.847×10^6	1.841×10^{15}
Fe-60		1.0×10^5 a	3.154×10^{12}	2.209×10^9
Ga-67	Gallium (31)	78.26 h	2.817×10^5	2.214×10^{16}
Ga-68		68 min	4.080×10^3	1.507×10^{18}
Ga-72		14.1 h	5.076×10^4	1.144×10^{17}
Gd-146	Gadolinium (64)	48.3 d	4.173×10^6	6.861×10^{14}
Gd-148		93 a	2.933×10^9	9.630×10^{11}
Gd-153		242 d	2.091×10^7	1.307×10^{14}
Gd-159		18.56 h	6.682×10^4	3.935×10^{16}
Ge-68	Germanium (32)	288 d	2.488×10^7	2.470×10^{14}
Ge-71		11.8 d	1.020×10^6	5.775×10^{15}
Ge-77		11.3 h	4.068×10^4	1.334×10^{17}
Hf-172	Hafnium (72)	1.87 a	5.897×10^7	4.121×10^{13}
Hf-175		70 d	6.048×10^6	3.949×10^{14}
Hf-181		42.4 d	3.663×10^6	6.304×10^{14}
Hf-182		9.0×10^6 a	2.838×10^{14}	8.092×10^6
Hg-194	Mercury (80)	260 a	8.199×10^9	2.628×10^{11}
Hg-195m		41.6 h	1.498×10^5	1.431×10^{16}
Hg-197		64.1 h	2.308×10^5	9.195×10^{15}
Hg-197m		23.8 h	8.568×10^4	2.476×10^{16}
Hg-203		46.6 d	4.026×10^6	5.114×10^{14}
Ho-166	Holmium (67)	26.8 h	9.648×10^4	2.610×10^{16}
Ho-166m		1200 a	3.784×10^{10}	6.654×10^{10}
I-123	Iodine (53)	13.2 h	4.752×10^4	7.151×10^{16}
I-124		4.18 d	3.612×10^5	9.334×10^{15}
I-125		60.14 d	5.196×10^6	6.436×10^{14}
I-126		13.02 d	1.125×10^6	2.949×10^{15}

TABLE II.1. (cont.)

Radionuclide	Element and atomic number	Half-life		Specific activity (Bq/g)
		$T_{1/2}$ (a,d,h,min)	$T_{1/2}$ (s)	
I-129		1.57×10^7 a	4.951×10^{14}	6.545×10^6
I-131		8.04 d	6.947×10^5	4.593×10^{15}
I-132		2.3 h	8.280×10^3	3.824×10^{17}
I-133		20.8 h	7.488×10^4	4.197×10^{16}
I-134		52.6 min	3.156×10^3	9.884×10^{17}
I-135		6.61 h	2.380×10^4	1.301×10^{17}
In-111	Indium (49)	2.83 d	2.445×10^5	1.540×10^{16}
In-113m		1.658 h	5.969×10^3	6.197×10^{17}
In-114m		49.51 d	4.278×10^6	8.572×10^{14}
In-115m		4.486 h	1.615×10^4	2.251×10^{17}
Ir-189	Iridium (77)	13.3 d	1.149×10^6	1.925×10^{15}
Ir-190		12.1 d	1.045×10^6	2.104×10^{15}
Ir-192		74.02 d	6.395×10^6	3.404×10^{14}
Ir-194		19.15 h	6.894×10^4	3.125×10^{16}
K-40	Potassium (19)	1.28×10^9 a	4.037×10^{16}	2.589×10^5
K-42		12.36 h	4.450×10^4	2.237×10^{17}
K-43		22.6 h	8.136×10^4	1.195×10^{17}
Kr-81	Krypton (36)	2.1×10^5 a	6.623×10^{12}	7.792×10^8
Kr-85		10.72 a	3.381×10^8	1.455×10^{13}
Kr-85m		4.48 h	1.613×10^4	3.049×10^{17}
Kr-87		76.3 min	4.578×10^3	1.049×10^{18}
La-137	Lanthanum (57)	6.0×10^4 a	1.892×10^{12}	1.612×10^9
La-140		40.272 h	1.450×10^5	2.059×10^{16}
Lu-172	Lutetium (71)	6.7 d	5.789×10^5	4.198×10^{15}
Lu-173		1.37 a	4.320×10^7	5.592×10^{13}
Lu-174		3.31 a	1.044×10^8	2.301×10^{13}
Lu-174m		142 d	1.227×10^7	1.958×10^{14}
Lu-177		6.71 d	5.797×10^5	4.073×10^{15}
Mg-28	Magnesium (12)	20.91 h	7.528×10^4	1.983×10^{17}
Mn-52	Manganese (25)	5.591 d	4.831×10^5	1.664×10^{16}

TABLE II.1. (cont.)

Radionuclide	Element and atomic number	Half-life		Specific activity (Bq/g)
		$T_{1/2}$ (a,d,h,min)	$T_{1/2}$ (s)	
Mn-53		3.7×10^6 a	1.167×10^{14}	6.759×10^7
Mn-54		312.5 d	2.700×10^7	2.867×10^{14}
Mn-56		2.5785 h	9.283×10^3	8.041×10^{17}
Mo-93	Molybdenum (42)	3500 a	1.104×10^{11}	4.072×10^{10}
Mo-99		66 h	2.376×10^5	1.777×10^{16}
N-13	Nitrogen (7)	9.965 min	5.979×10^2	5.378×10^{19}
Na-22	Sodium (11)	2.602 a	8.206×10^7	2.315×10^{14}
Na-24		15 h	5.400×10^4	3.225×10^{17}
Nb-93m	Niobium (41)	13.6 a	4.289×10^8	1.048×10^{13}
Nb-94		2.03×10^4 a	6.402×10^{11}	6.946×10^9
Nb-95		35.15 d	3.037×10^6	1.449×10^{15}
Nb-97		72.1 min	4.326×10^3	9.961×10^{17}
Nd-147	Neodymium (60)	10.98 d	9.487×10^5	2.997×10^{15}
Nd-149		1.73 h	6.228×10^3	4.504×10^{17}
Ni-59	Nickel (28)	7.5×10^4 a	2.365×10^{12}	2.995×10^9
Ni-63		96 a	3.027×10^9	2.192×10^{12}
Ni-65		2.52 h	9.072×10^3	7.089×10^{17}
Np-235	Neptunium (93)	396.1 d	3.422×10^7	5.197×10^{13}
Np-236 (long lived)		1.15×10^5 a	3.627×10^{12}	4.884×10^8
Np-236 (short lived)		22.5 h	8.100×10^4	2.187×10^{16}
Np-237		2.14×10^6 a	6.749×10^{13}	2.613×10^7
Np-239		2.355 d	2.035×10^5	8.596×10^{15}
Os-185	Osmium (76)	94 d	8.122×10^6	2.782×10^{14}
Os-191		15.4 d	1.331×10^6	1.645×10^{15}
Os-191m		13.03 h	4.691×10^4	4.665×10^{16}
Os-193		30 h	1.080×10^5	2.005×10^{16}
Os-194		6 a	1.892×10^8	1.139×10^{13}
P-32	Phosphorus (15)	14.29 d	1.235×10^6	1.058×10^{16}
P-33		25.4 d	2.195×10^6	5.772×10^{15}

TABLE II.1. (cont.)

Radionuclide	Element and atomic number	Half-life		Specific activity (Bq/g)
		$T_{1/2}$ (a,d,h,min)	$T_{1/2}$ (s)	
Pa-230	Protactinium (91)	17.4 d	1.503×10^6	1.209×10^{15}
Pa-231		32 760 a	1.033×10^{12}	1.752×10^9
Pa-233		27 d	2.333×10^6	7.690×10^{14}
Pb-201	Lead (82)	9.4 h	3.384×10^4	6.145×10^{16}
Pb-202		3.0×10^5 a	9.461×10^{12}	2.187×10^8
Pb-203		52.05 h	1.874×10^5	1.099×10^{16}
Pb-205		1.43×10^7 a	4.510×10^{14}	4.521×10^6
Pb-210		22.3 a	7.033×10^8	2.830×10^{12}
Pb-212		10.64 h	3.830×10^4	5.147×10^{16}
Pd-103		Palladium (46)	16.96 d	1.465×10^6
Pd-107	6.5×10^6 a		2.050×10^{14}	1.906×10^7
Pd-109	13.427 h		4.834×10^4	7.934×10^{16}
Pm-143	Promethium (61)	265 d	2.290×10^7	1.277×10^{14}
Pm-144		363 d	3.136×10^7	9.255×10^{13}
Pm-145		17.7 a	5.582×10^8	5.165×10^{12}
Pm-147		2.6234 a	8.273×10^7	3.437×10^{13}
Pm-148m		41.3 d	3.568×10^6	7.915×10^{14}
Pm-149		53.08 h	1.911×10^5	1.468×10^{16}
Pm-151		28.4 h	1.022×10^5	2.708×10^{16}
Po-210		Polonium (84)	138.38 d	1.196×10^7
Pr-142	Praseodymium (59)	19.13 h	6.887×10^4	4.274×10^{16}
Pr-143		13.56 d	1.172×10^6	2.495×10^{15}
Pt-188	Platinum (78)	10.2 d	8.813×10^5	2.523×10^{15}
Pt-191		2.8 d	2.419×10^5	9.046×10^{15}
Pt-193		50 a	1.577×10^9	1.374×10^{12}
Pt-193m		4.33 d	3.741×10^5	5.789×10^{15}
Pt-195m		4.02 d	3.473×10^5	6.172×10^{15}
Pt-197		18.3 h	6.588×10^4	3.221×10^{16}
Pt-197m		94.4 min	5.664×10^3	3.746×10^{17}
Pu-236		Plutonium (94)	2.851 a	8.991×10^7
Pu-237	45.3 d		3.914×10^6	4.506×10^{14}

TABLE II.1. (cont.)

Radionuclide	Element and atomic number	Half-life		Specific activity (Bq/g)
		$T_{1/2}$ (a,d,h,min)	$T_{1/2}$ (s)	
Pu-238		87.74 a	2.767×10^9	6.347×10^{11}
Pu-239		24 065 a	7.589×10^{11}	2.305×10^9
Pu-240		6537 a	2.062×10^{11}	8.449×10^9
Pu-241		14.4 a	4.541×10^8	3.819×10^{12}
Pu-242		3.763×10^5 a	1.187×10^{13}	1.456×10^8
Pu-244		8.26×10^7 a	2.605×10^{15}	6.577×10^5
Ra-223	Radium (88)	11.434 d	9.879×10^5	1.897×10^{15}
Ra-224		3.66 d	3.162×10^5	5.901×10^{15}
Ra-225		14.8 d	1.279×10^6	1.453×10^{15}
Ra-226		1600 a	5.046×10^{10}	3.666×10^{10}
Ra-228		5.75 a	1.813×10^8	1.011×10^{13}
Rb-81	Rubidium (37)	4.58 h	1.649×10^4	3.130×10^{17}
Rb-83		86.2 d	7.448×10^6	6.762×10^{14}
Rb-84		32.77 d	2.831×10^6	1.758×10^{15}
Rb-86		18.66 d	1.612×10^6	3.015×10^{15}
Rb-87		4.7×10^{10} a	1.482×10^{18}	3.242×10^3
Re-184	Rhenium (75)	38 d	3.283×10^6	6.919×10^{14}
Re-184m		165 d	1.426×10^7	1.594×10^{14}
Re-186		90.64 h	3.263×10^5	6.887×10^{15}
Re-187		5.0×10^{10} a	1.577×10^{18}	1.418×10^3
Re-188		16.98 h	6.113×10^4	3.637×10^{16}
Re-189		24.3 h	8.748×10^4	2.528×10^{16}
Rh-99	Rhodium (45)	16 d	1.382×10^6	3.054×10^{15}
Rh-101		3.2 a	1.009×10^8	4.101×10^{13}
Rh-102		2.9 a	9.145×10^7	4.481×10^{13}
Rh-102m		207 d	1.788×10^7	2.291×10^{14}
Rh-103m		56.12 min	3.367×10^3	1.205×10^{18}
Rh-105		35.36 h	1.273×10^5	3.127×10^{16}
Rn-222	Radon (86)	3.8235 d	3.304×10^5	5.700×10^{15}
Ru-97	Ruthenium (44)	2.9 d	2.506×10^5	1.720×10^{16}
Ru-103		39.28 d	3.394×10^6	1.196×10^{15}
Ru-105		4.44 h	1.598×10^4	2.491×10^{17}
Ru-106		368.2 d	3.181×10^7	1.240×10^{14}

TABLE II.1. (cont.)

Radionuclide	Element and atomic number	Half-life		Specific activity (Bq/g)
		$T_{1/2}$ (a,d,h,min)	$T_{1/2}$ (s)	
S-35	Sulphur (16)	87.44 d	7.555×10^6	1.581×10^{15}
Sb-122	Antimony (51)	2.7 d	2.333×10^5	1.469×10^{16}
Sb-124		60.2 d	5.201×10^6	6.481×10^{14}
Sb-125		2.77 a	8.735×10^7	3.828×10^{13}
Sb-126		12.4 d	1.071×10^6	3.096×10^{15}
Sc-44	Scandium (21)	3.927 h	1.414×10^4	6.720×10^{17}
Sc-46		83.83 d	7.243×10^6	1.255×10^{15}
Sc-47		3.351 d	2.895×10^5	3.072×10^{16}
Sc-48		43.7 h	1.573×10^5	5.535×10^{16}
Se-75	Selenium (34)	119.8 d	1.035×10^7	5.384×10^{14}
Se-79		6.5×10^4 a	2.050×10^{12}	2.581×10^9
Si-31	Silicon (14)	157.3 min	9.438×10^3	1.429×10^{18}
Si-32		450 a	1.419×10^{10}	9.205×10^{11}
Sm-145	Samarium (62)	340 d	2.938×10^7	9.813×10^{13}
Sm-147		1.06×10^{11} a	3.343×10^{18}	8.506×10^2
Sm-151		90 a	2.838×10^9	9.753×10^{11}
Sm-153		46.7 h	1.681×10^5	1.625×10^{16}
Sn-113	Tin (50)	115.1 d	9.945×10^6	3.720×10^{14}
Sn-117m		13.61 d	1.176×10^6	3.038×10^{15}
Sn-119m		293 d	2.532×10^7	1.388×10^{14}
Sn-121m		55 a	1.734×10^9	1.992×10^{12}
Sn-123		129.2 d	1.116×10^7	3.044×10^{14}
Sn-125		9.64 d	8.329×10^5	4.015×10^{15}
Sn-126		1.0×10^5 a	3.154×10^{12}	1.052×10^9
Sr-82		Strontium (38)	25 d	2.160×10^6
Sr-85	64.84 d		5.602×10^6	8.778×10^{14}
Sr-85m	69.5 min		4.170×10^3	1.179×10^{18}
Sr-87m	2.805 h		1.010×10^4	4.758×10^{17}
Sr-89	50.5 d		4.363×10^6	1.076×10^{15}
Sr-90	29.12 a		9.183×10^8	5.057×10^{12}
Sr-91	9.5 h		3.420×10^4	1.343×10^{17}
Sr-92	2.71 h		9.756×10^3	4.657×10^{17}

TABLE II.1. (cont.)

Radionuclide	Element and atomic number	Half-life		Specific activity (Bq/g)
		$T_{1/2}$ (a,d,h,min)	$T_{1/2}$ (s)	
T(H-3)	Tritium (1)	12.35 a	3.895×10^8	3.578×10^{14}
Ta-178 (long lived)	Tantalum (73)	2.2 h	7.920×10^3	2.965×10^{17}
Ta-179		664.9 d	5.745×10^7	4.065×10^{13}
Ta-182		115 d	9.936×10^6	2.311×10^{14}
Tb-157	Terbium (65)	150 a	4.730×10^9	5.628×10^{11}
Tb-158		150 a	4.730×10^9	5.593×10^{11}
Tb-160		72.3 d	6.247×10^6	4.182×10^{14}
Tc-95m	Technetium (43)	61 d	5.270×10^6	8.349×10^{14}
Tc-96		4.28 d	3.698×10^5	1.177×10^{16}
Tc-96m		51.5 min	3.090×10^3	1.409×10^{18}
Tc-97		2.6×10^6 a	8.199×10^{13}	5.256×10^7
Tc-97m		87 d	7.517×10^6	5.733×10^{14}
Tc-98		4.2×10^6 a	1.325×10^{14}	3.220×10^7
Tc-99		2.13×10^5 a	6.717×10^{12}	6.286×10^8
Tc-99m		6.02 h	2.167×10^4	1.948×10^{17}
Te-121	Tellurium (52)	17 d	1.469×10^6	2.352×10^{15}
Te-121m		154 d	1.331×10^7	2.596×10^{14}
Te-123m		119.7 d	1.034×10^7	3.286×10^{14}
Te-125m		58 d	5.011×10^6	6.673×10^{14}
Te-127		9.35 h	3.366×10^4	9.778×10^{16}
Te-127m		109 d	9.418×10^6	3.495×10^{14}
Te-129		69.6 min	4.176×10^3	7.759×10^{17}
Te-129m		33.6 d	2.903×10^6	1.116×10^{15}
Te-131m		30 h	1.080×10^5	2.954×10^{16}
Te-132		78.2 h	2.815×10^5	1.125×10^{16}
Th-227	Thorium (90)	18.718 d	1.617×10^6	1.139×10^{15}
Th-228		1.9131 a	6.033×10^7	3.039×10^{13}
Th-229		7340 a	2.315×10^{11}	7.886×10^9
Th-230		7.7×10^4 a	2.428×10^{12}	7.484×10^8
Th-231		25.52 h	9.187×10^4	1.970×10^{16}
Th-232		1.405×10^{10} a	4.431×10^{17}	4.066×10^3
Th-234		24.1 d	2.082×10^6	8.579×10^{14}

TABLE II.1. (cont.)

Radionuclide	Element and atomic number	Half-life		Specific activity (Bq/g)
		$T_{1/2}$ (a,d,h,min)	$T_{1/2}$ (s)	
Ti-44	Titanium (22)	47.3 a	1.492×10^9	6.369×10^{12}
Tl-200	Thallium (81)	26.1 h	9.396×10^4	2.224×10^{16}
Tl-201		3.044 d	2.630×10^5	7.907×10^{15}
Tl-202		12.23 d	1.057×10^6	1.958×10^{15}
Tl-204		3.779 a	1.192×10^8	1.719×10^{13}
Tm-167	Thulium (69)	9.24 d	7.983×10^5	3.135×10^{15}
Tm-170		128.6 d	1.111×10^7	2.213×10^{14}
Tm-171		1.92 a	6.055×10^7	4.037×10^{13}
U-230	Uranium (92)	20.8 d	1.797×10^6	1.011×10^{15}
U-232		72 a	2.271×10^9	7.935×10^{11}
U-233		1.585×10^5 a	4.998×10^{12}	3.589×10^8
U-234		2.445×10^5 a	7.711×10^{12}	2.317×10^8
U-235		7.038×10^8 a	2.220×10^{16}	8.014×10^4
U-236		2.3415×10^7 a	7.384×10^{14}	2.399×10^6
U-238		4.468×10^9 a	1.409×10^{17}	1.246×10^4
V-48		Vanadium (23)	16.238 d	1.403×10^6
V-49	330 d		2.851×10^7	2.992×10^{14}
W-178	Tungsten (74)	21.7 d	1.875×10^6	1.253×10^{15}
W-181		121.2 d	1.047×10^7	2.205×10^{14}
W-185		75.1 d	6.489×10^6	3.482×10^{14}
W-187		23.9 h	8.604×10^4	2.598×10^{16}
W-188		69.4 d	5.996×10^6	3.708×10^{14}
Xe-122	Xenon (54)	20.1 h	7.236×10^4	4.735×10^{16}
Xe-123		2.08 h	7.488×10^3	4.538×10^{17}
Xe-127		36.41 d	3.146×10^6	1.046×10^{15}
Xe-131m		11.9 d	1.028×10^6	3.103×10^{15}
Xe-133		5.245 d	4.532×10^5	6.935×10^{15}
Xe-135		9.09 h	3.272×10^4	9.462×10^{16}
Y-87	Yttrium (39)	80.3 h	2.891×10^5	1.662×10^{16}
Y-88		106.64 d	9.214×10^6	5.155×10^{14}
Y-90		64 h	2.304×10^5	2.016×10^{16}

TABLE II.1. (cont.)

Radionuclide	Element and atomic number	Half-life		Specific activity (Bq/g)
		$T_{1/2}$ (a,d,h,min)	$T_{1/2}$ (s)	
Y-91		58.51 d	5.055×10^6	9.086×10^{14}
Y-91m		49.71 min	2.983×10^3	1.540×10^{18}
Y-92		3.54 h	1.274×10^4	3.565×10^{17}
Y-93		10.1 h	3.636×10^4	1.236×10^{17}
Yb-169	Ytterbium (70)	32.01 d	2.766×10^6	8.943×10^{14}
Yb-175		4.19 d	3.620×10^5	6.598×10^{15}
Zn-65	Zinc (30)	243.9 d	2.107×10^7	3.052×10^{14}
Zn-69		57 min	3.420×10^3	1.771×10^{18}
Zn-69m		13.76 h	4.954×10^4	1.223×10^{17}
Zr-88	Zirconium (40)	83.4 d	7.206×10^6	6.592×10^{14}
Zr-93		1.53×10^6 a	4.825×10^{13}	9.315×10^7
Zr-95		63.98 d	5.528×10^6	7.960×10^{14}
Zr-97		16.9 h	6.084×10^4	7.083×10^{16}

TABLE II.2. DOSE AND DOSE RATE COEFFICIENTS OF RADIONUCLIDES

EXPLANATORY NOTES

- (a) Effective dose rate coefficient for external dose due to photons calculated at 1 m.
 (b) Effective dose rate coefficient for external dose due to beta emission calculated at 1 m.
 (c) Effective dose coefficient for inhalation.
 (d) Skin dose coefficient for the skin dose contamination.
 (*) For the effective dose coefficient for submersion dose due to gaseous isotopes see Table I.1 of Appendix I.

Radionuclide	\dot{e}_{pt} (a) (Sv·Bq ⁻¹ ·h ⁻¹)	\dot{e}_{β} (b) (Sv·Bq ⁻¹ ·h ⁻¹)	e_{inh} (c) (Sv·Bq ⁻¹)	h_{skin} (d) (Sv·m ² ·TBq ⁻¹ ·s ⁻¹)
Ac-225	2.0×10^{-14}	1.2×10^{-12}	7.9×10^{-06}	9.3×10^{-02}
Ac-227	9.6×10^{-17}	7.7×10^{-15}	5.4×10^{-04}	7.6×10^{-04}
Ac-228	8.3×10^{-14}	1.8×10^{-12}	2.5×10^{-08}	5.3×10^{-02}
Ag-105	5.0×10^{-14}	1.0×10^{-15}	7.8×10^{-10}	1.1×10^{-03}
Ag-108m	1.5×10^{-13}	1.7×10^{-13}	3.5×10^{-08}	4.7×10^{-03}
Ag-110m	2.4×10^{-13}	5.3×10^{-14}	1.2×10^{-08}	1.4×10^{-02}
Ag-111	2.4×10^{-15}	5.3×10^{-13}	1.7×10^{-09}	4.5×10^{-02}
Al-26	2.3×10^{-13}	7.1×10^{-12}	1.8×10^{-08}	3.9×10^{-02}
Am-241	3.3×10^{-15}	1.0×10^{-15}	3.9×10^{-05}	7.4×10^{-05}
Am-242m	2.5×10^{-15}	2.0×10^{-14}	3.5×10^{-05}	3.3×10^{-02}
Am-243	2.0×10^{-14}	3.8×10^{-15}	3.9×10^{-05}	6.8×10^{-02}
Ar-37	1.0×10^{-16}	1.0×10^{-15}	—	2.8×10^{-05}
Ar-39 (*)	—	1.4×10^{-14}	—	—
Ar-41 (*)	1.1×10^{-13}	3.2×10^{-12}	—	—
As-72	1.6×10^{-13}	3.6×10^{-12}	9.2×10^{-10}	4.2×10^{-02}
As-73	1.1×10^{-15}	1.0×10^{-15}	9.3×10^{-10}	2.8×10^{-05}
As-74	7.1×10^{-14}	5.9×10^{-13}	2.1×10^{-09}	2.9×10^{-02}
As-76	4.0×10^{-14}	4.0×10^{-12}	7.4×10^{-10}	4.7×10^{-02}
As-77	7.7×10^{-16}	5.6×10^{-14}	3.8×10^{-10}	4.2×10^{-02}
At-211	4.0×10^{-15}	1.0×10^{-15}	9.8×10^{-08}	6.3×10^{-05}

TABLE II.2. (cont.)

Radionuclide	\dot{e}_{pt} (a) (Sv·Bq ⁻¹ ·h ⁻¹)	\dot{e}_{β} (b) (Sv·Bq ⁻¹ ·h ⁻¹)	e_{inh} (c) (Sv·Bq ⁻¹)	\dot{h}_{skin} (d) (Sv·m ² ·TBq ⁻¹ ·s ⁻¹)
Au-193	1.4×10^{-14}	1.0×10^{-15}	1.2×10^{-10}	1.5×10^{-02}
Au-194	9.1×10^{-14}	1.0×10^{-15}	2.5×10^{-10}	4.6×10^{-03}
Au-195	7.7×10^{-15}	1.0×10^{-15}	1.6×10^{-09}	5.0×10^{-03}
Au-198	3.8×10^{-14}	9.1×10^{-13}	8.4×10^{-10}	4.6×10^{-02}
Au-199	7.1×10^{-15}	1.0×10^{-15}	7.5×10^{-10}	4.4×10^{-02}
Ba-131	6.3×10^{-14}	1.0×10^{-15}	2.6×10^{-10}	1.3×10^{-02}
Ba-133	3.8×10^{-14}	1.0×10^{-15}	1.5×10^{-09}	2.7×10^{-03}
Ba-133m	6.7×10^{-15}	1.0×10^{-15}	1.9×10^{-10}	4.5×10^{-02}
Ba-140	1.6×10^{-13}	2.2×10^{-12}	2.1×10^{-09}	9.0×10^{-02}
Be-7	4.8×10^{-15}	1.0×10^{-15}	5.2×10^{-11}	2.8×10^{-05}
Be-10	—	1.7×10^{-14}	3.2×10^{-08}	14.8×10^{-02}
Bi-205	1.4×10^{-13}	1.0×10^{-15}	9.2×10^{-10}	2.5×10^{-03}
Bi-206	2.9×10^{-13}	1.0×10^{-15}	1.7×10^{-09}	2.4×10^{-02}
Bi-207	1.4×10^{-13}	1.0×10^{-15}	5.2×10^{-09}	5.5×10^{-03}
Bi-210		7.7×10^{-13}	8.4×10^{-08}	4.5×10^{-02}
Bi-210m	2.3×10^{-14}	1.6×10^{-12}	3.1×10^{-06}	5.7×10^{-02}
Bi-212	1.0×10^{-13}	1.5×10^{-12}	3.0×10^{-08}	4.8×10^{-02}
Bk-247	9.1×10^{-15}	1.0×10^{-15}	6.5×10^{-05}	2.0×10^{-02}
Bk-249	1.0×10^{-16}	1.0×10^{-15}	1.5×10^{-07}	2.3×10^{-03}
Br-76	2.3×10^{-13}	1.6×10^{-12}	4.2×10^{-10}	2.8×10^{-02}
Br-77	2.9×10^{-14}	1.0×10^{-15}	8.7×10^{-11}	1.2×10^{-03}
Br-82	2.4×10^{-13}	1.0×10^{-15}	6.4×10^{-10}	3.6×10^{-02}
C-11	1.0×10^{-13}	5.0×10^{-13}	5.0×10^{-11}	4.8×10^{-02}
C-14	—	1.0×10^{-15}	5.8×10^{-10}	8.8×10^{-03}
Ca-41	1.0×10^{-16}	1.0×10^{-15}	—	—
Ca-45	1.0×10^{-16}	1.0×10^{-15}	2.7×10^{-09}	2.3×10^{-02}
Ca-47	3.7×10^{-14}	2.7×10^{-14}	2.5×10^{-09}	8.4×10^{-02}
Cd-109	3.4×10^{-15}	1.0×10^{-15}	8.1×10^{-09}	1.4×10^{-02}
Cd-113m	—	1.1×10^{-14}	1.1×10^{-07}	4.0×10^{-02}
Cd-115	2.6×10^{-14}	3.0×10^{-13}	1.1×10^{-09}	7.1×10^{-02}

TABLE II.2. (cont.)

Radionuclide	\dot{e}_{pt} (a) (Sv·Bq ⁻¹ ·h ⁻¹)	\dot{e}_{β} (b) (Sv·Bq ⁻¹ ·h ⁻¹)	e_{inh} (c) (Sv·Bq ⁻¹)	\dot{h}_{skin} (d) (Sv·m ² ·TBq ⁻¹ ·s ⁻¹)
Cd-115m	2.0×10^{-15}	1.9×10^{-12}	7.3×10^{-09}	4.6×10^{-02}
Ce-139	1.5×10^{-14}	1.0×10^{-15}	1.8×10^{-09}	1.3×10^{-02}
Ce-141	6.3×10^{-15}	3.1×10^{-15}	3.6×10^{-09}	4.8×10^{-02}
Ce-143	2.7×10^{-14}	1.1×10^{-12}	8.1×10^{-10}	4.6×10^{-02}
Ce-144	4.5×10^{-15}	4.0×10^{-12}	4.9×10^{-08}	7.3×10^{-02}
Cf-248	1.5×10^{-16}	1.0×10^{-15}	8.2×10^{-06}	2.8×10^{-05}
Cf-249	3.1×10^{-14}	1.0×10^{-15}	6.6×10^{-05}	6.1×10^{-03}
Cf-250	1.5×10^{-16}	1.0×10^{-15}	3.2×10^{-05}	2.8×10^{-05}
Cf-251	1.1×10^{-14}	1.0×10^{-15}	6.7×10^{-05}	5.4×10^{-02}
Cf-252	2.1×10^{-12}	1.0×10^{-15}	1.8×10^{-05}	5.4×10^{-05}
Cf-253	8.1×10^{-18}	1.0×10^{-15}	1.2×10^{-06}	2.3×10^{-02}
Cf-254	7.1×10^{-11}	1.0×10^{-15}	3.7×10^{-05}	2.8×10^{-05}
Cl-36	1.0×10^{-16}	1.0×10^{-13}	6.9×10^{-09}	4.4×10^{-02}
Cl-38	1.2×10^{-13}	4.5×10^{-12}	4.7×10^{-11}	5.0×10^{-02}
Cm-240	2.2×10^{-16}	1.0×10^{-15}	2.9×10^{-06}	2.8×10^{-05}
Cm-241	4.5×10^{-14}	1.0×10^{-15}	3.8×10^{-08}	1.9×10^{-02}
Cm-242	2.0×10^{-16}	1.0×10^{-15}	4.8×10^{-06}	2.8×10^{-05}
Cm-243	1.2×10^{-14}	1.0×10^{-15}	3.8×10^{-05}	3.4×10^{-02}
Cm-244	1.9×10^{-16}	1.0×10^{-15}	3.1×10^{-05}	2.8×10^{-05}
Cm-245	7.9×10^{-15}	1.0×10^{-15}	5.5×10^{-05}	1.0×10^{-02}
Cm-246	1.7×10^{-16}	1.0×10^{-15}	5.5×10^{-05}	2.8×10^{-05}
Cm-247	3.1×10^{-14}	6.3×10^{-15}	5.1×10^{-05}	—
Cm-248	5.6×10^{-12}	1.0×10^{-15}	2.0×10^{-04}	—
Co-55	1.9×10^{-13}	1.0×10^{-12}	5.5×10^{-10}	3.6×10^{-02}
Co-56	3.0×10^{-13}	6.7×10^{-14}	6.3×10^{-09}	9.5×10^{-03}
Co-57	1.0×10^{-14}	1.0×10^{-15}	9.4×10^{-10}	2.1×10^{-03}
Co-58	9.1×10^{-14}	1.3×10^{-15}	2.0×10^{-09}	7.4×10^{-03}
Co-58m	1.0×10^{-16}	1.0×10^{-15}	5.0×10^{-11}	2.8×10^{-05}
Co-60	2.2×10^{-13}	1.4×10^{-15}	2.9×10^{-08}	2.9×10^{-02}
Cr-51	2.9×10^{-15}	1.0×10^{-15}	5.0×10^{-11}	2.8×10^{-05}
Cs-129	2.8×10^{-14}	1.0×10^{-15}	5.0×10^{-11}	7.4×10^{-04}

TABLE II.2. (cont.)

Radionuclide	\dot{e}_{pt} (a) (Sv·Bq ⁻¹ ·h ⁻¹)	\dot{e}_p (b) (Sv·Bq ⁻¹ ·h ⁻¹)	e_{inh} (c) (Sv·Bq ⁻¹)	\dot{h}_{skin} (d) (Sv·m ² ·TBq ⁻¹ ·s ⁻¹)
Cs-131	3.2×10^{-15}	1.0×10^{-15}	5.0×10^{-11}	2.8×10^{-05}
Cs-132	6.7×10^{-14}	1.0×10^{-15}	2.4×10^{-10}	1.1×10^{-03}
Cs-134	1.4×10^{-13}	2.8×10^{-13}	6.8×10^{-09}	3.0×10^{-02}
Cs-134m	2.7×10^{-15}	1.0×10^{-15}	5.0×10^{-11}	4.4×10^{-02}
Cs-135	—	1.0×10^{-15}	—	1.9×10^{-02}
Cs-136	2.0×10^{-13}	1.2×10^{-15}	1.3×10^{-09}	4.0×10^{-02}
Cs-137	5.6×10^{-14}	1.2×10^{-13}	4.8×10^{-09}	4.4×10^{-02}
Cu-64	1.8×10^{-14}	9.1×10^{-15}	1.2×10^{-10}	2.4×10^{-02}
Cu-67	1.0×10^{-14}	2.4×10^{-15}	5.8×10^{-10}	4.0×10^{-02}
Dy-159	5.0×10^{-15}	1.0×10^{-15}	3.5×10^{-10}	2.8×10^{-05}
Dy-165	2.4×10^{-15}	1.1×10^{-12}	6.1×10^{-11}	4.6×10^{-02}
Dy-166	2.9×10^{-15}	1.2×10^{-12}	2.5×10^{-09}	8.1×10^{-02}
Er-169	1.0×10^{-16}	1.0×10^{-15}	9.8×10^{-10}	2.9×10^{-02}
Er-171	3.4×10^{-14}	1.2×10^{-12}	2.2×10^{-10}	5.5×10^{-02}
Eu-147	4.5×10^{-14}	1.0×10^{-15}	1.0×10^{-09}	7.4×10^{-03}
Eu-148	2.0×10^{-13}	1.0×10^{-15}	2.7×10^{-09}	1.4×10^{-03}
Eu-149	6.7×10^{-15}	1.0×10^{-15}	2.7×10^{-10}	3.8×10^{-04}
Eu-150 (long lived)	1.4×10^{-13}	1.0×10^{-15}	5.0×10^{-08}	3.9×10^{-03}
Eu-150 (short lived)	4.3×10^{-15}	6.7×10^{-13}	1.9×10^{-10}	4.0×10^{-02}
Eu-152	1.0×10^{-13}	5.9×10^{-15}	3.9×10^{-08}	2.1×10^{-02}
Eu-152m	2.7×10^{-14}	1.2×10^{-12}	2.2×10^{-10}	3.6×10^{-02}
Eu-154	1.1×10^{-13}	6.3×10^{-13}	5.0×10^{-08}	5.0×10^{-02}
Eu-155	5.3×10^{-15}	1.0×10^{-15}	6.5×10^{-09}	8.7×10^{-03}
Eu-156	1.1×10^{-13}	1.4×10^{-12}	3.3×10^{-09}	4.2×10^{-02}
F-18	1.0×10^{-13}	3.6×10^{-14}	6.0×10^{-11}	4.8×10^{-02}
Fe-52	2.4×10^{-13}	3.1×10^{-12}	6.3×10^{-10}	7.4×10^{-02}
Fe-55	1.0×10^{-16}	1.0×10^{-15}	7.7×10^{-10}	2.8×10^{-05}
Fe-59	1.1×10^{-13}	2.3×10^{-14}	3.5×10^{-09}	3.1×10^{-02}
Fe-60	5.0×10^{-16}	1.0×10^{-15}	2.4×10^{-07}	7.6×10^{-03}

TABLE II.2. (cont.)

Radionuclide	\dot{e}_{pt} (a) (Sv·Bq ⁻¹ ·h ⁻¹)	\dot{e}_{β} (b) (Sv·Bq ⁻¹ ·h ⁻¹)	e_{inh} (c) (Sv·Bq ⁻¹)	\dot{h}_{skin} (d) (Sv·m ² ·TBq ⁻¹ ·s ⁻¹)
Ga-67	1.4×10^{-14}	1.0×10^{-15}	2.3×10^{-10}	8.6×10^{-03}
Ga-68	9.1×10^{-14}	2.2×10^{-12}	5.1×10^{-11}	4.2×10^{-02}
Ga-72	2.3×10^{-13}	2.7×10^{-12}	5.5×10^{-10}	4.5×10^{-02}
Gd-146	1.9×10^{-13}	3.4×10^{-15}	6.8×10^{-09}	2.7×10^{-02}
Gd-148	—	—	2.5×10^{-05}	—
Gd-153	1.1×10^{-14}	1.0×10^{-15}	2.1×10^{-09}	3.1×10^{-03}
Gd-159	4.8×10^{-15}	3.2×10^{-13}	2.7×10^{-10}	4.4×10^{-02}
Ge-68	9.1×10^{-14}	2.2×10^{-12}	1.3×10^{-08}	4.2×10^{-02}
Ge-71	1.9×10^{-16}	1.0×10^{-15}	5.0×10^{-11}	2.8×10^{-05}
Ge-77	9.1×10^{-14}	3.0×10^{-12}	3.6×10^{-10}	4.6×10^{-02}
Hf-172	1.7×10^{-13}	1.0×10^{-15}	3.2×10^{-08}	1.6×10^{-02}
Hf-175	3.4×10^{-14}	1.0×10^{-15}	1.1×10^{-09}	5.9×10^{-03}
Hf-181	5.3×10^{-14}	1.0×10^{-15}	4.7×10^{-09}	5.6×10^{-02}
Hf-182	2.2×10^{-14}	1.0×10^{-15}	—	—
Hg-194	9.1×10^{-14}	1.0×10^{-15}	4.0×10^{-08}	4.6×10^{-03}
Hg-195m	3.2×10^{-14}	1.0×10^{-15}	9.4×10^{-09}	3.8×10^{-02}
Hg-197	6.3×10^{-15}	1.0×10^{-15}	4.4×10^{-09}	1.8×10^{-03}
Hg-197m	7.7×10^{-15}	1.0×10^{-15}	6.2×10^{-09}	7.9×10^{-02}
Hg-203	2.2×10^{-14}	1.0×10^{-15}	7.5×10^{-09}	2.5×10^{-02}
Ho-166	2.6×10^{-15}	2.3×10^{-12}	6.6×10^{-10}	4.8×10^{-02}
Ho-166m	1.6×10^{-13}	1.0×10^{-15}	1.1×10^{-07}	2.2×10^{-02}
I-123	1.6×10^{-14}	1.0×10^{-15}	2.1×10^{-10}	9.5×10^{-03}
I-124	9.1×10^{-14}	1.7×10^{-13}	1.2×10^{-08}	1.1×10^{-02}
I-125	6.3×10^{-15}	1.0×10^{-15}	1.4×10^{-08}	2.8×10^{-05}
I-126	4.3×10^{-14}	1.6×10^{-13}	2.9×10^{-08}	2.1×10^{-02}
I-129	3.4×10^{-15}	1.0×10^{-15}	—	—
I-131	3.6×10^{-14}	5.0×10^{-14}	2.0×10^{-08}	4.0×10^{-02}
I-132	2.1×10^{-13}	2.3×10^{-12}	2.8×10^{-10}	4.6×10^{-02}
I-133	5.6×10^{-14}	1.4×10^{-12}	4.5×10^{-09}	4.5×10^{-02}
I-134	2.4×10^{-13}	3.1×10^{-12}	7.2×10^{-11}	4.7×10^{-02}
I-135	1.2×10^{-13}	1.6×10^{-12}	9.6×10^{-10}	4.5×10^{-02}

TABLE II.2. (cont.)

Radionuclide	\dot{e}_{pt} (a) (Sv·Bq ⁻¹ ·h ⁻¹)	\dot{e}_{β} (b) (Sv·Bq ⁻¹ ·h ⁻¹)	e_{inh} (c) (Sv·Bq ⁻¹)	\dot{h}_{skin} (d) (Sv·m ² ·TBq ⁻¹ ·s ⁻¹)
In-111	3.6×10^{-14}	1.0×10^{-15}	2.3×10^{-10}	9.3×10^{-03}
In-113m	2.4×10^{-14}	1.0×10^{-15}	5.0×10^{-11}	1.7×10^{-02}
In-114m	9.1×10^{-15}	1.0×10^{-15}	9.3×10^{-09}	5.8×10^{-02}
In-115m	1.5×10^{-14}	1.0×10^{-15}	6.0×10^{-11}	2.7×10^{-02}
Ir-189	7.7×10^{-15}	1.0×10^{-15}	5.5×10^{-10}	1.6×10^{-03}
Ir-190	1.3×10^{-13}	1.0×10^{-15}	2.3×10^{-09}	3.7×10^{-02}
Ir-192	7.7×10^{-14}	2.2×10^{-14}	6.2×10^{-09}	4.5×10^{-02}
Ir-194	8.3×10^{-15}	3.0×10^{-12}	5.6×10^{-10}	4.7×10^{-02}
K-40	1.4×10^{-14}	1.1×10^{-12}	—	—
K-42	2.4×10^{-14}	4.5×10^{-12}	1.3×10^{-10}	4.9×10^{-02}
K-43	9.1×10^{-14}	1.4×10^{-12}	1.5×10^{-10}	4.5×10^{-02}
Kr-81	(*) 9.1×10^{-16}	1.0×10^{-15}	—	—
Kr-85	(*) 2.1×10^{-16}	7.1×10^{-14}	—	—
Kr-85m	(*) 1.3×10^{-14}	1.3×10^{-13}	—	—
Kr-87	(*) 6.7×10^{-14}	4.8×10^{-12}	—	—
La-137	3.3×10^{-15}	1.0×10^{-15}	8.6×10^{-09}	2.8×10^{-05}
La-140	2.0×10^{-13}	2.7×10^{-12}	1.1×10^{-09}	4.7×10^{-02}
Lu-172	1.7×10^{-13}	1.0×10^{-15}	1.5×10^{-09}	1.3×10^{-02}
Lu-173	1.3×10^{-14}	1.0×10^{-15}	2.3×10^{-09}	1.6×10^{-03}
Lu-174	1.2×10^{-14}	1.0×10^{-15}	4.0×10^{-09}	9.6×10^{-04}
Lu-174m	6.3×10^{-15}	1.0×10^{-15}	3.8×10^{-09}	7.5×10^{-04}
Lu-177	3.0×10^{-15}	1.0×10^{-15}	1.1×10^{-09}	3.8×10^{-02}
Mg-28	2.7×10^{-13}	4.0×10^{-12}	1.9×10^{-09}	8.7×10^{-02}
Mn-52	3.1×10^{-13}	1.4×10^{-15}	1.4×10^{-09}	1.5×10^{-02}
Mn-53	1.0×10^{-16}	1.0×10^{-15}	—	—
Mn-54	7.7×10^{-14}	1.0×10^{-15}	1.5×10^{-09}	2.8×10^{-05}
Mn-56	1.5×10^{-13}	3.3×10^{-12}	1.3×10^{-10}	4.7×10^{-02}
Mo-93	1.2×10^{-15}	1.0×10^{-15}	2.2×10^{-09}	2.8×10^{-05}
Mo-99	1.6×10^{-14}	8.0×10^{-13}	9.7×10^{-10}	5.1×10^{-02}

TABLE II.2. (cont.)

Radionuclide	\dot{e}_{pt} (a) (Sv·Bq ⁻¹ ·h ⁻¹)	\dot{e}_{β} (b) (Sv·Bq ⁻¹ ·h ⁻¹)	e_{inh} (c) (Sv·Bq ⁻¹)	\dot{h}_{skin} (d) (Sv·m ² ·TBq ⁻¹ ·s ⁻¹)
N-13	1.0×10^{-13}	1.1×10^{-12}	—	4.8×10^{-02}
Na-22	2.0×10^{-13}	2.6×10^{-13}	1.3×10^{-09}	4.2×10^{-02}
Na-24	3.3×10^{-13}	5.0×10^{-12}	2.9×10^{-10}	4.7×10^{-02}
Nb-93m	2.0×10^{-16}	1.0×10^{-15}	1.6×10^{-09}	2.8×10^{-05}
Nb-94	1.5×10^{-13}	1.0×10^{-15}	4.5×10^{-08}	4.0×10^{-02}
Nb-95	7.1×10^{-14}	1.0×10^{-15}	1.6×10^{-09}	7.0×10^{-03}
Nb-97	6.3×10^{-14}	1.1×10^{-12}	4.7×10^{-11}	4.6×10^{-02}
Nd-147	1.4×10^{-14}	1.8×10^{-13}	2.3×10^{-09}	4.3×10^{-02}
Nd-149	3.4×10^{-14}	1.6×10^{-12}	9.0×10^{-11}	5.4×10^{-02}
Ni-59	1.0×10^{-16}	1.0×10^{-15}	—	—
Ni-63	—	1.0×10^{-15}	1.7×10^{-09}	2.8×10^{-05}
Ni-65	4.8×10^{-14}	2.3×10^{-12}	8.7×10^{-11}	4.6×10^{-02}
Np-235	7.1×10^{-16}	1.0×10^{-15}	4.0×10^{-10}	2.8×10^{-05}
Np-236 (long lived)	1.1×10^{-14}	1.0×10^{-15}	3.0×10^{-06}	5.6×10^{-02}
Np-236 (short lived)	4.3×10^{-15}	1.0×10^{-15}	5.0×10^{-09}	1.9×10^{-02}
Np-237	3.3×10^{-15}	1.0×10^{-15}	2.1×10^{-05}	—
Np-239	1.5×10^{-14}	3.8×10^{-15}	9.0×10^{-10}	6.7×10^{-02}
Os-185	6.7×10^{-14}	1.0×10^{-15}	1.5×10^{-09}	1.2×10^{-03}
Os-191	6.7×10^{-15}	1.0×10^{-15}	1.8×10^{-09}	1.2×10^{-02}
Os-191m	7.7×10^{-16}	1.0×10^{-15}	1.5×10^{-10}	1.0×10^{-03}
Os-193	6.7×10^{-15}	6.3×10^{-13}	5.1×10^{-10}	4.7×10^{-02}
Os-194	8.3×10^{-15}	3.2×10^{-12}	7.9×10^{-08}	4.7×10^{-02}
P-32	—	2.2×10^{-12}	3.2×10^{-09}	4.7×10^{-02}
P-33	—	1.0×10^{-15}	1.4×10^{-09}	2.3×10^{-02}
Pa-230	6.0×10^{-14}	1.0×10^{-15}	7.6×10^{-07}	1.3×10^{-02}
Pa-231	1.1×10^{-14}	1.0×10^{-15}	1.3×10^{-04}	1.5×10^{-03}
Pa-233	1.9×10^{-14}	1.0×10^{-15}	3.7×10^{-09}	4.2×10^{-02}

TABLE II.2. (cont.)

Radionuclide	\dot{e}_{pt} (a) (Sv·Bq ⁻¹ ·h ⁻¹)	\dot{e}_{β} (b) (Sv·Bq ⁻¹ ·h ⁻¹)	e_{inh} (c) (Sv·Bq ⁻¹)	\dot{h}_{skin} (d) (Sv·m ² ·TBq ⁻¹ ·s ⁻¹)
Pb-201	6.7×10^{-14}	1.0×10^{-15}	6.5×10^{-11}	8.4×10^{-03}
Pb-202	1.1×10^{-16}	1.0×10^{-15}	—	1.7×10^{-03}
Pb-203	2.8×10^{-14}	1.0×10^{-15}	9.1×10^{-11}	1.1×10^{-02}
Pb-205	1.2×10^{-16}	1.0×10^{-15}	—	—
Pb-210	4.2×10^{-16}	7.7×10^{-13}	9.8×10^{-07}	4.5×10^{-02}
Pb-212	1.0×10^{-13}	1.4×10^{-12}	2.3×10^{-07}	1.0×10^{-01}
Pd-103	2.1×10^{-15}	1.0×10^{-15}	4.0×10^{-10}	2.8×10^{-05}
Pd-107	—	1.0×10^{-15}	—	—
Pd-109	1.4×10^{-15}	5.3×10^{-13}	3.6×10^{-10}	5.9×10^{-02}
Pm-143	3.0×10^{-14}	1.0×10^{-15}	1.4×10^{-09}	7.7×10^{-05}
Pm-144	1.5×10^{-13}	1.0×10^{-15}	7.8×10^{-09}	8.2×10^{-04}
Pm-145	3.8×10^{-15}	1.0×10^{-15}	3.4×10^{-09}	2.8×10^{-05}
Pm-147	1.0×10^{-16}	1.0×10^{-15}	4.7×10^{-09}	1.6×10^{-02}
Pm-148m	1.2×10^{-13}	1.3×10^{-13}	5.4×10^{-09}	3.9×10^{-02}
Pm-149	1.0×10^{-15}	5.9×10^{-13}	7.2×10^{-10}	4.5×10^{-02}
Pm-151	3.0×10^{-14}	5.6×10^{-13}	4.5×10^{-10}	4.5×10^{-02}
Po-210	7.9×10^{-19}	1.0×10^{-15}	3.0×10^{-06}	2.8×10^{-05}
Pr-142	5.0×10^{-15}	2.8×10^{-12}	5.6×10^{-10}	4.6×10^{-02}
Pr-143	1.0×10^{-16}	3.3×10^{-13}	2.3×10^{-09}	4.4×10^{-02}
Pt-188	1.0×10^{-13}	1.0×10^{-15}	8.8×10^{-10}	3.6×10^{-02}
Pt-191	2.8×10^{-14}	1.0×10^{-15}	1.1×10^{-10}	7.9×10^{-03}
Pt-193	1.1×10^{-16}	1.0×10^{-15}	5.0×10^{-11}	2.8×10^{-05}
Pt-193m	1.1×10^{-15}	1.0×10^{-15}	1.3×10^{-10}	5.1×10^{-02}
Pt-195m	6.7×10^{-15}	1.0×10^{-15}	1.9×10^{-10}	5.7×10^{-02}
Pt-197	2.1×10^{-15}	4.2×10^{-14}	9.1×10^{-11}	4.4×10^{-02}
Pt-197m	7.7×10^{-15}	1.0×10^{-15}	5.0×10^{-11}	4.8×10^{-02}
Pu-236	2.2×10^{-16}	1.0×10^{-15}	1.8×10^{-05}	4.3×10^{-05}
Pu-237	4.3×10^{-15}	1.0×10^{-15}	3.6×10^{-10}	2.3×10^{-04}
Pu-238	1.9×10^{-16}	1.0×10^{-15}	4.3×10^{-05}	2.8×10^{-05}
Pu-239	7.5×10^{-17}	1.0×10^{-15}	4.7×10^{-05}	—
Pu-240	1.8×10^{-16}	1.0×10^{-15}	4.7×10^{-05}	—
Pu-241	1.0×10^{-16}	1.0×10^{-15}	8.5×10^{-07}	2.8×10^{-05}

TABLE II.2. (cont.)

Radionuclide	\dot{e}_{pt} (a) (Sv·Bq ⁻¹ ·h ⁻¹)	\dot{e}_{p} (b) (Sv·Bq ⁻¹ ·h ⁻¹)	e_{inh} (c) (Sv·Bq ⁻¹)	\dot{h}_{skin} (d) (Sv·m ² ·TBq ⁻¹ ·s ⁻¹)
Pu-242	1.5×10^{-16}	1.0×10^{-15}	4.4×10^{-05}	—
Pu-244	3.2×10^{-14}	2.6×10^{-12}	4.4×10^{-05}	—
Ra-223	2.6×10^{-14}	2.5×10^{-12}	6.9×10^{-06}	1.1×10^{-01}
Ra-224	9.1×10^{-14}	2.3×10^{-12}	3.1×10^{-06}	1.0×10^{-01}
Ra-225	8.3×10^{-15}	4.5×10^{-12}	1.4×10^{-05}	1.2×10^{-01}
Ra-226	1.5×10^{-13}	4.0×10^{-12}	1.9×10^{-05}	1.0×10^{-01}
Ra-228	8.3×10^{-14}	1.8×10^{-12}	2.6×10^{-06}	5.3×10^{-02}
Rb-81	5.9×10^{-14}	6.7×10^{-14}	5.0×10^{-11}	3.4×10^{-02}
Rb-83	4.8×10^{-14}	1.0×10^{-15}	7.1×10^{-10}	6.4×10^{-05}
Rb-84	8.3×10^{-14}	2.5×10^{-14}	1.1×10^{-09}	1.2×10^{-02}
Rb-86	8.3×10^{-15}	2.1×10^{-12}	9.6×10^{-10}	4.6×10^{-02}
Rb-87	—	1.0×10^{-15}	—	—
Rb(nat)	—	1.0×10^{-15}	—	—
Re-184	8.3×10^{-14}	1.0×10^{-15}	1.8×10^{-09}	1.6×10^{-02}
Re-184m	3.6×10^{-14}	1.0×10^{-15}	6.1×10^{-09}	2.2×10^{-02}
Re-186	1.7×10^{-15}	5.0×10^{-13}	1.1×10^{-09}	4.7×10^{-02}
Re-187	—	1.0×10^{-15}	—	—
Re-188	5.0×10^{-15}	2.9×10^{-12}	5.5×10^{-10}	5.2×10^{-02}
Re-189	3.1×10^{-15}	4.0×10^{-13}	4.3×10^{-10}	4.9×10^{-02}
Re(nat)	—	1.0×10^{-15}	—	—
Rh-99	5.6×10^{-14}	1.0×10^{-15}	8.3×10^{-10}	3.7×10^{-03}
Rh-101	2.3×10^{-14}	1.0×10^{-15}	5.0×10^{-09}	1.1×10^{-02}
Rh-102	2.0×10^{-13}	1.0×10^{-15}	1.6×10^{-08}	5.1×10^{-04}
Rh-102m	4.5×10^{-14}	1.1×10^{-13}	6.7×10^{-09}	1.5×10^{-02}
Rh-103m	2.2×10^{-16}	1.0×10^{-15}	5.0×10^{-11}	2.8×10^{-05}
Rh-105	7.1×10^{-15}	5.6×10^{-15}	3.4×10^{-10}	3.5×10^{-02}
Rn-222	1.5×10^{-13}	3.8×10^{-12}	—	—
Ru-97	2.1×10^{-14}	1.0×10^{-15}	1.1×10^{-10}	2.1×10^{-03}
Ru-103	4.5×10^{-14}	5.0×10^{-15}	2.8×10^{-09}	1.8×10^{-02}
Ru-105	7.1×10^{-14}	8.3×10^{-13}	1.8×10^{-10}	4.5×10^{-02}
Ru-106	1.9×10^{-14}	4.5×10^{-12}	6.2×10^{-08}	4.9×10^{-02}

TABLE II.2. (cont.)

Radionuclide	\dot{e}_{pt} (a) (Sv·Bq ⁻¹ ·h ⁻¹)	\dot{e}_β (b) (Sv·Bq ⁻¹ ·h ⁻¹)	e_{inh} (c) (Sv·Bq ⁻¹)	\dot{h}_{skin} (d) (Sv·m ² ·TBq ⁻¹ ·s ⁻¹)
S-35	—	1.0×10^{-15}	1.3×10^{-09}	9.4×10^{-03}
Sb-122	4.2×10^{-14}	2.3×10^{-12}	1.0×10^{-09}	4.5×10^{-02}
Sb-124	1.6×10^{-13}	1.4×10^{-12}	6.1×10^{-09}	4.0×10^{-02}
Sb-125	4.2×10^{-14}	4.0×10^{-15}	4.5×10^{-09}	2.1×10^{-02}
Sb-126	2.6×10^{-13}	7.7×10^{-13}	2.7×10^{-09}	3.9×10^{-02}
Sc-44	2.0×10^{-13}	1.6×10^{-12}	1.9×10^{-10}	4.5×10^{-02}
Sc-46	1.9×10^{-13}	1.0×10^{-15}	6.4×10^{-09}	3.3×10^{-02}
Sc-47	9.1×10^{-15}	5.9×10^{-15}	7.0×10^{-10}	3.9×10^{-02}
Sc-48	3.0×10^{-13}	1.1×10^{-12}	1.1×10^{-09}	4.3×10^{-02}
Se-75	3.4×10^{-14}	1.0×10^{-15}	1.4×10^{-09}	2.8×10^{-03}
Se-79	—	1.0×10^{-15}	2.9×10^{-09}	1.2×10^{-02}
Si-31	1.0×10^{-16}	1.7×10^{-12}	8.0×10^{-11}	4.7×10^{-02}
Si-32	—	1.0×10^{-15}	1.1×10^{-07}	1.7×10^{-02}
Sm-145	7.7×10^{-15}	1.0×10^{-15}	1.5×10^{-09}	2.8×10^{-05}
Sm-147	—	—	—	—
Sm-151	1.0×10^{-16}	1.0×10^{-15}	3.7×10^{-09}	2.8×10^{-05}
Sm-153	5.9×10^{-15}	1.1×10^{-13}	6.1×10^{-10}	4.5×10^{-02}
Sn-113	2.7×10^{-14}	1.0×10^{-15}	2.5×10^{-09}	1.7×10^{-02}
Sn-117m	1.4×10^{-14}	1.0×10^{-15}	2.3×10^{-09}	7.0×10^{-02}
Sn-119m	1.6×10^{-15}	1.0×10^{-15}	2.0×10^{-09}	2.8×10^{-05}
Sn-121m	7.0×10^{-16}	1.0×10^{-15}	4.2×10^{-09}	3.3×10^{-02}
Sn-123	6.3×10^{-16}	1.3×10^{-12}	7.7×10^{-09}	4.5×10^{-02}
Sn-125	2.8×10^{-14}	2.7×10^{-12}	3.0×10^{-09}	4.5×10^{-02}
Sn-126	1.5×10^{-13}	1.7×10^{-12}	2.7×10^{-08}	7.7×10^{-02}
Sr-82	1.0×10^{-13}	4.2×10^{-12}	1.0×10^{-08}	4.7×10^{-02}
Sr-85	4.8×10^{-14}	1.0×10^{-15}	7.7×10^{-10}	3.3×10^{-04}
Sr-85m	1.9×10^{-14}	1.0×10^{-15}	5.0×10^{-11}	1.5×10^{-03}
Sr-87m	3.0×10^{-14}	1.0×10^{-15}	5.0×10^{-11}	8.5×10^{-03}
Sr-89	1.0×10^{-16}	1.6×10^{-12}	7.5×10^{-09}	4.6×10^{-02}
Sr-90	1.0×10^{-16}	3.1×10^{-12}	1.5×10^{-07}	8.8×10^{-02}
Sr-91	6.6×10^{-14}	3.3×10^{-12}	4.1×10^{-10}	4.6×10^{-02}

TABLE II.2. (cont.)

Radionuclide	\dot{e}_{pt} (a) (Sv·Bq ⁻¹ ·h ⁻¹)	\dot{e}_{β} (b) (Sv·Bq ⁻¹ ·h ⁻¹)	e_{inh} (c) (Sv·Bq ⁻¹)	\dot{h}_{skin} (d) (Sv·m ² ·TBq ⁻¹ ·s ⁻¹)
Sr-92	1.2×10^{-14}	9.1×10^{-13}	4.2×10^{-10}	8.9×10^{-02}
T(H-3)	—	1.0×10^{-15}	5.0×10^{-11}	—
Ta-178 (2.2 h)	9.1×10^{-14}	1.0×10^{-15}	6.9×10^{-11}	3.4×10^{-02}
Ta-179	3.2×10^{-15}	1.0×10^{-15}	5.2×10^{-10}	2.8×10^{-05}
Ta-182	1.1×10^{-13}	7.7×10^{-14}	9.7×10^{-09}	5.2×10^{-02}
Tb-157	3.2×10^{-16}	1.0×10^{-15}	1.1×10^{-09}	2.8×10^{-05}
Tb-158	7.1×10^{-14}	6.3×10^{-15}	4.3×10^{-08}	1.5×10^{-02}
Tb-160	1.0×10^{-13}	4.3×10^{-13}	6.6×10^{-09}	4.8×10^{-02}
Tc-95m	6.7×10^{-14}	1.0×10^{-15}	8.7×10^{-10}	2.3×10^{-03}
Tc-96	2.3×10^{-13}	1.0×10^{-15}	7.1×10^{-10}	2.0×10^{-04}
Tc-96m	2.3×10^{-13}	1.0×10^{-15}	7.0×10^{-10}	2.0×10^{-04}
Tc-97	1.3×10^{-15}	1.0×10^{-15}	—	—
Tc-97m	1.2×10^{-15}	1.0×10^{-15}	3.1×10^{-09}	1.9×10^{-02}
Tc-98	1.3×10^{-13}	1.0×10^{-15}	—	4.1×10^{-02}
Tc-99	—	1.0×10^{-15}	—	3.1×10^{-02}
Tc-99m	1.0×10^{-14}	1.0×10^{-15}	5.0×10^{-11}	6.5×10^{-03}
Te-121	5.6×10^{-14}	1.0×10^{-15}	3.9×10^{-10}	2.8×10^{-04}
Te-121m	2.0×10^{-14}	1.0×10^{-15}	4.2×10^{-09}	1.1×10^{-02}
Te-123m	1.3×10^{-14}	1.0×10^{-15}	3.9×10^{-09}	2.4×10^{-02}
Te-125m	5.0×10^{-15}	1.0×10^{-15}	3.3×10^{-09}	3.1×10^{-02}
Te-127	4.5×10^{-16}	5.3×10^{-14}	1.2×10^{-10}	4.2×10^{-02}
Te-127m	2.0×10^{-15}	5.3×10^{-14}	7.2×10^{-09}	5.6×10^{-02}
Te-129	5.9×10^{-15}	1.5×10^{-12}	5.0×10^{-11}	4.6×10^{-02}
Te-129m	7.7×10^{-15}	1.2×10^{-12}	6.3×10^{-09}	6.3×10^{-02}
Te-131m	1.3×10^{-13}	8.3×10^{-13}	1.1×10^{-09}	5.7×10^{-02}
Te-132	2.0×10^{-13}	2.0×10^{-12}	2.2×10^{-09}	6.6×10^{-02}
Th-227	9.1×10^{-15}	1.0×10^{-15}	9.6×10^{-06}	5.9×10^{-03}
Th-228	1.3×10^{-13}	1.9×10^{-12}	3.9×10^{-05}	1.0×10^{-01}
Th-229	8.1×10^{-15}	1.0×10^{-15}	9.9×10^{-05}	1.6×10^{-02}
Th-230	1.4×10^{-16}	1.0×10^{-15}	4.0×10^{-05}	—
Th-231	2.6×10^{-15}	1.0×10^{-15}	3.1×10^{-06}	2.3×10^{-02}
Th-232	8.3×10^{-14}	1.0×10^{-15}	—	—

TABLE II.2. (cont.)

Radionuclide	\dot{e}_{pt} (a) (Sv·Bq ⁻¹ ·h ⁻¹)	\dot{e}_β (b) (Sv·Bq ⁻¹ ·h ⁻¹)	e_{inh} (c) (Sv·Bq ⁻¹)	\dot{h}_{skin} (d) (Sv·m ² ·TBq ⁻¹ ·s ⁻¹)
Th-234	2.4×10^{-15}	3.3×10^{-12}	7.3×10^{-09}	5.6×10^{-02}
Th(nat)	2.2×10^{-13}	3.7×10^{-12}	—	—
Ti-44	2.1×10^{-13}	1.6×10^{-12}	1.2×10^{-07}	4.5×10^{-02}
Tl-200	1.2×10^{-13}	1.0×10^{-15}	1.4×10^{-10}	3.9×10^{-03}
Tl-201	8.3×10^{-15}	1.0×10^{-15}	4.7×10^{-11}	7.0×10^{-03}
Tl-202	4.3×10^{-14}	1.0×10^{-15}	2.0×10^{-10}	1.7×10^{-03}
Tl-204	1.0×10^{-16}	1.0×10^{-13}	4.4×10^{-10}	4.0×10^{-02}
Tm-167	1.4×10^{-14}	1.0×10^{-15}	1.1×10^{-09}	3.4×10^{-02}
Tm-170	5.0×10^{-16}	3.8×10^{-13}	6.6×10^{-09}	4.5×10^{-02}
Tm-171	1.0×10^{-16}	1.0×10^{-15}	1.3×10^{-09}	2.7×10^{-04}
U-230 (F)	1.9×10^{-15}	1.0×10^{-15}	3.6×10^{-07}	9.0×10^{-03}
U-230 (M)	1.9×10^{-15}	1.0×10^{-15}	1.2×10^{-05}	9.0×10^{-03}
U-230 (S)	1.9×10^{-15}	1.0×10^{-15}	1.5×10^{-05}	9.0×10^{-03}
U-232 (F)	2.1×10^{-16}	1.0×10^{-15}	4.0×10^{-06}	1.5×10^{-04}
U-232 (M)	2.1×10^{-16}	1.0×10^{-15}	7.2×10^{-06}	1.5×10^{-04}
U-232 (S)	2.1×10^{-16}	1.0×10^{-15}	3.5×10^{-05}	1.5×10^{-04}
U-233 (F)	1.3×10^{-16}	1.0×10^{-15}	5.7×10^{-07}	—
U-233 (M)	1.3×10^{-16}	1.0×10^{-15}	3.2×10^{-06}	—
U-233 (S)	1.3×10^{-16}	1.0×10^{-15}	8.7×10^{-06}	—
U-234 (F)	1.7×10^{-16}	1.0×10^{-15}	5.5×10^{-07}	—
U-234 (M)	1.7×10^{-16}	1.0×10^{-15}	3.1×10^{-06}	—
U-234 (S)	1.7×10^{-16}	1.0×10^{-15}	8.5×10^{-06}	—
U-235 (F)	1.6×10^{-14}	1.0×10^{-15}	—	—
U-235 (M)	1.6×10^{-14}	1.0×10^{-15}	—	—
U-235 (S)	1.6×10^{-14}	1.0×10^{-15}	—	—
U-236 (F)	1.5×10^{-16}	1.0×10^{-15}	—	—
U-236 (M)	1.5×10^{-16}	1.0×10^{-15}	2.9×10^{-06}	—
U-236 (S)	1.5×10^{-16}	1.0×10^{-15}	7.9×10^{-06}	—
U-238 (F)	1.3×10^{-16}	1.0×10^{-15}	—	—
U-238 (M)	1.3×10^{-16}	1.0×10^{-15}	—	—
U-238 (S)	1.3×10^{-16}	1.0×10^{-15}	—	—
U(nat)	1.6×10^{-13}	7.9×10^{-12}	—	—
U(dep)	2.2×10^{-15}	3.1×10^{-12}	—	—

TABLE II.2. (cont.)

Radionuclide	\dot{e}_{pt} (a) (Sv·Bq ⁻¹ ·h ⁻¹)	\dot{e}_{β} (b) (Sv·Bq ⁻¹ ·h ⁻¹)	e_{inh} (c) (Sv·Bq ⁻¹)	\dot{h}_{skin} (d) (Sv·m ² ·TBq ⁻¹ ·s ⁻¹)
V-48	2.6×10^{-13}	3.3×10^{-13}	2.3×10^{-09}	2.5×10^{-02}
V-49	1.0×10^{-16}	1.0×10^{-15}	5.0×10^{-11}	2.8×10^{-05}
W-178	1.1×10^{-14}	1.0×10^{-15}	7.6×10^{-11}	6.1×10^{-03}
W-181	3.8×10^{-15}	1.0×10^{-15}	5.0×10^{-11}	5.2×10^{-05}
W-185	1.0×10^{-16}	1.0×10^{-15}	1.4×10^{-10}	3.4×10^{-02}
W-187	4.5×10^{-14}	4.8×10^{-13}	2.0×10^{-10}	4.5×10^{-02}
W-188	5.0×10^{-15}	2.7×10^{-12}	1.1×10^{-09}	7.9×10^{-02}
Xe-122	(*) 9.1×10^{-14}	2.5×10^{-12}	—	—
Xe-123	(*) 5.6×10^{-14}	1.0×10^{-13}	—	—
Xe-127	(*) 2.6×10^{-14}	1.0×10^{-15}	—	—
Xe-131m	(*) 2.6×10^{-15}	1.0×10^{-15}	—	—
Xe-133	(*) 4.8×10^{-15}	1.0×10^{-15}	—	—
Xe-135	(*) 2.2×10^{-14}	2.9×10^{-13}	—	—
Y-87	7.1×10^{-14}	1.0×10^{-15}	4.0×10^{-10}	8.7×10^{-03}
Y-88	2.3×10^{-13}	1.0×10^{-15}	4.1×10^{-09}	1.3×10^{-04}
Y-90	1.0×10^{-16}	3.1×10^{-12}	1.5×10^{-09}	4.7×10^{-02}
Y-91	3.2×10^{-16}	1.7×10^{-12}	8.4×10^{-09}	4.6×10^{-02}
Y-91m	5.0×10^{-14}	1.0×10^{-15}	5.0×10^{-11}	2.3×10^{-03}
Y-92	2.3×10^{-14}	4.5×10^{-12}	2.0×10^{-10}	4.9×10^{-02}
Y-93	7.7×10^{-15}	3.8×10^{-12}	4.3×10^{-10}	4.8×10^{-02}
Yb-169	2.9×10^{-14}	1.0×10^{-15}	2.8×10^{-09}	2.7×10^{-02}
Yb-175	3.7×10^{-15}	1.0×10^{-15}	7.0×10^{-10}	3.2×10^{-02}
Zn-65	5.3×10^{-14}	1.0×10^{-15}	2.9×10^{-09}	6.7×10^{-04}
Zn-69	1.0×10^{-16}	3.1×10^{-13}	5.0×10^{-11}	4.5×10^{-02}
Zn-69m	2.9×10^{-14}	2.5×10^{-13}	2.9×10^{-10}	4.7×10^{-02}
Zr-88	3.8×10^{-14}	1.0×10^{-15}	3.5×10^{-09}	1.3×10^{-03}
Zr-93	—	1.0×10^{-15}	—	—
Zr-95	5.6×10^{-14}	2.2×10^{-15}	5.5×10^{-09}	3.3×10^{-02}
Zr-97	1.1×10^{-13}	2.7×10^{-12}	1.0×10^{-09}	4.9×10^{-02}

TABLE II.3. SPECIFIC ACTIVITY VALUES FOR URANIUM AT VARIOUS LEVELS OF ENRICHMENT

Mass per cent of U-235 present in uranium mixture	Specific activity ^{a,b}	
	Bq/g	Ci/g
0.45	1.8×10^4	5.0×10^{-7}
0.72 (natural)	2.6×10^4	7.06×10^{-7}
1.0	2.8×10^4	7.6×10^{-7}
1.5	3.7×10^4	1.0×10^{-6}
5.0	1.0×10^5	2.7×10^{-6}
10.0	1.8×10^5	4.8×10^{-6}
20.0	3.7×10^5	1.0×10^{-5}
35.0	7.4×10^5	2.0×10^{-5}
50.0	9.3×10^5	2.5×10^{-5}
90.0	2.2×10^6	5.8×10^{-5}
93.0	2.6×10^6	7.0×10^{-5}
95.0	3.4×10^6	9.1×10^{-5}

^a The values of the specific activity include the activity of U-234, which is concentrated during the enrichment process; these values do not include any daughter product contribution. The values are for the material originating from natural uranium enriched by a gaseous diffusion method.

^b If the origin of the material is not known, the specific activity should be either measured or calculated by using isotopic ratio data.

REFERENCE TO APPENDIX II

[II.1] INTERNATIONAL COMMISSION ON RADIATION PROTECTION, ICRP
Publication No. 38, Vols 11–13, Pergamon Press, Oxford and New York (1983).

Appendix III

EXAMPLE CALCULATIONS FOR ESTABLISHING MINIMUM SEGREGATION DISTANCE REQUIREMENTS

INTRODUCTION

III.1. Segregation is used in the Regulations for transport and storage in transit in three ways:

- (1) To separate radioactive material packages from places regularly occupied by people for providing adequate radiation protection (paras 306 and 562(a));
- (2) To separate radioactive material packages from packages of undeveloped photographic film for providing protection of the film from inadvertent exposure or 'fogging' (paras 307 and 562(a)); and
- (3) To separate radioactive material packages from packages of other dangerous goods (paras 506 and 562(b)).

III.2. This appendix provides guidance on one way of developing criteria for segregating radioactive material packages from areas regularly occupied by workers and members of the public. A similar procedure can be used for developing criteria for protection of undeveloped film. A method for segregating radioactive material packages from other dangerous goods is briefly summarized in para. 562.8.

III.3. Generally, modal transport authorities accomplish segregation for radiation protection by establishing tables of minimum segregation distances which are based upon the limiting values for dose required by para. 306 of the Regulations.

III.4. The procedure outlined below is conservative in many ways. For example, the limiting values for dose from para. 306 are applied at the boundary to a regularly occupied area. Since persons will move around within the occupied area during the period when radioactive material packages are present, their resultant exposure will be less than the limiting values [III.1]. The radiation levels used in the procedure are based on the transport index (TI) of a package or on the summation of the TIs in an array of packages. Thus, for arrays of packages, self-shielding within the array is not considered, and actual radiation levels will be lower than those upon which the calculations are based.

III.5. To establish minimum segregation distance requirements by this method, it is first necessary to develop a model of transport conditions for a given mode of

transport. Numerous variables need to be considered in the development of the model. These considerations are well known and have been documented in previous calculations made for air transport [III.2, III.3] and for sea transport [III.2]. Important parameters in such a model include:

- (a) The maximum annual travel periods (MATPs) for crew and for the critical groups of members of the public;
- (b) The radioactive traffic factor (RTF), defined as the ratio of the annual number of journeys made in company with category II-YELLOW and category III-YELLOW packages of radioactive materials³ to the annual total of all journeys;
- (c) The maximum annual exposure times (MAETs), for both crew and members of the public, which are the relevant MATP multiplied by the appropriate RTF, i.e.

$$\text{MAET (h/a)} = \text{MATP (h/a)} \times \text{RTF} \quad (\text{III.1})$$

- (d) The applicable dose values (DVs) from para. 306 for crew and members of the public; and
- (e) The reference dose rates (RDRs) for crew and members of the public, which are used as the basis for establishing the minimum segregation distances and are derived by dividing the dose values by the applicable maximum annual exposure time, i.e.

$$\text{RDR (mSv/h)} = \text{DV (mSv/a)} / \text{MAET (h/a)} \quad (\text{III.2})$$

III.6. The following provides an example of how segregation distances may be determined for the situations of passenger and cargo aircraft. This example is based upon a particular set of assumptions and calculational techniques. Other calculational techniques are also possible. Three possible configurations are considered as follows:

- (a) Below main deck stowage in a passenger aircraft of radioactive material packages in a single group;
- (b) Below main deck stowage in a passenger aircraft of radioactive material packages in multiple groups with prescribed spacing distances between groups; and
- (c) Main deck stowage on either a combined cargo/passenger aircraft (known in the airline industry as a 'combi' aircraft) or a cargo aircraft.

³ Category I-WHITE packages are excluded from this because they present no essential radiation exposure hazard.

III.7. In the following calculations, all packages and groups of packages are treated as single point sources whose radiation levels can be described by the inverse square relationship. Consideration of the details of package dimensions and of the stowage configurations will generally lead to a small decrease in the segregation distance required; thus, treating all groups of packages as single point sources is conservative.

BELOW MAIN DECK STOWAGE OF ONE GROUP OF PACKAGES IN PASSENGER AIRCRAFT

III.8. In a typical passenger carrying aircraft, packages are loaded in a cargo compartment directly below the passenger compartment. The highest radiation level would be experienced by a passenger located in a seat directly above a package or group of packages of radioactive material. All other passengers would be exposed to lower levels. This situation is depicted in Fig. III.1.

III.9. The actual minimum distance (AMD) of segregation needed between a source within a package (or group of packages) and the point of interest (representing a passenger) on a typical aircraft will be the sum of the required segregation distances (S, in metres) between the package and the passenger compartment boundary, the height of the seat (although the actual seat height in most aircraft would be approximately 0.5 m, it is conservatively assumed to be 0.4 m here) and the radius of the package (r, in metres):

$$AMD = S + 0.4 + r \tag{III.3}$$

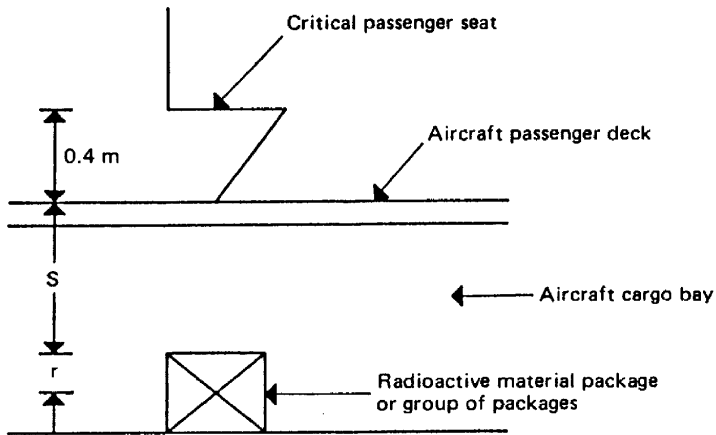

FIG. III.1. Typical configuration of passenger and cargo in passenger aircraft, used for determining the segregation distance S.

III.10. The TI provides an accurate measure of the maximum radiation level at 1 m from the package surface. In order to use the SI radiological units of measurement, the TI needs to be divided by a factor of 100. Hence, the inverse square law gives:

$$\text{RDR} = (\text{TI}/100)(\text{TF}_f)(1.0 + r)^2/(\text{AMD})^2 \quad (\text{III.4})$$

where

RDR is the reference dose rate at seat height (mSv/h),

TI is the transport index which, when divided by 100, is an expression of the radiation level at 1 m from the package surface (mSv/h),

TF_f is the transmission factor of the passenger compartment floor, i.e. the fraction of radiation which passes through the aircraft structures between the source and the dose point (dimensionless),

r is the radius of a package or a collection of packages (half of the minimum dimension) (m) and

AMD is the actual minimum distance to the dose point (m).

III.11. Substitution of Eq. (III.3) into Eq. (III.4) yields:

$$\text{RDR} = (\text{TI}/100)(\text{TF}_f)(1.0 + r)^2/(\text{S} + 0.4 + r)^2 \quad (\text{III.5})$$

Solving for S, we obtain:

$$\text{S} = [(\text{TI} \times \text{TF}_f)/(\text{100} \times \text{RDR})]^{1/2} (1 + r) - (r + 0.4) \quad (\text{III.6})$$

III.12. The transmission factor (TF_f) varies with the energy of the radiation emitted from the package and the aircraft floor construction. Typical transmission factors range from 0.7 to 1.0. The combinations of TI, transmission factor and package size shown in Table III.1 were selected as conservative but realistic models.

TABLE III.1. TRANSMISSION FACTORS

Transport index (TI)	Transmission factor (TF_f)	Package radius (r) (m)
0-1.0	1.0	0.05
1.1-2.0	0.8	0.1
2.1-50	0.7	0.4

TABLE III.2. VARIATION OF SEGREGATION DISTANCE WITH TRANSPORT INDEX FOR A SINGLE GROUP OF PACKAGES STOWED BELOW MAIN DECK ON A PASSENGER AIRCRAFT

Total of TIs for packages in the group	Vertical segregation distance (from top of group of packages to floor of main deck (m))	
	Calculated here ^a	In 1995–1996 ICAO Technical Instructions ^b
1.0	0.29	0.30
2.0	0.48	0.50
3.0	0.63	0.70
4.0	0.86	0.85
5.0	1.05	1.00
6.0	1.23	1.15
7.0	1.39	1.30
8.0	1.54	1.45
9.0	1.68	1.55
10.0	1.82	1.65

^a Calculated using Eq. (III.6) and assumptions outlined in this appendix.

^b ICAO Technical Instructions for the Safe Transport of Dangerous Goods by Air [III.5].

III.13. The reference dose rate (RDR) is determined from Eqs (III.1) and (III.2). It is assumed that RTF is 1 in 10 [III.4]. Data need to be developed to establish an internationally applicable value of RTF for the development of sound segregation tables. It is estimated that regular commuters such as sales persons may fly 500 hours each year, hence the MATP for the critical group is assumed to equal 500 h/a. Thus, from Eq. (III.1) we obtain:

$$\text{MAET} = (500 \text{ h/a}) \times (0.1) = 50 \text{ h/a}$$

III.14. The applicable DV for a passenger, from para. 306(b) of the Regulations, is 1.0 mSv/a; and thus the applicable RDR, from Eq. (III.2), is:

$$\text{RDR} = (1 \text{ mSv/a}) / (50 \text{ h/a}) = 0.02 \text{ mSv/h}$$

III.15. For below main deck stowage on passenger aircraft the exposure to pilots should be minimal because of the location of the cockpit relative to the cargo areas.

III.16. With these assumptions, Eq. (III.6) is used to calculate the segregation distances shown in column two of Table III.2. Also shown for comparison are the segregation values used in the 1995 edition of the International Civil Aviation Organization's Technical Instructions [III.5]. For use in international transport organization regulations, values such as these are often rounded for convenience.

BELOW MAIN DECK STOWAGE OF MULTIPLE GROUPS OF PACKAGES IN PASSENGER AIRCRAFT

III.17. It should be noted that the calculated vertical segregation distance of 1.05 m for a single package or group of packages with a TI of 5 can be obtained in most aircraft, but that for many aircraft it would be impossible to obtain a vertical segregation distance above 1.6 m. This would limit the total TI in one group of packages which could be placed on a passenger aircraft. To increase the total TI which can be carried on a passenger aircraft, it would be necessary to space the packages or groups of packages within the belly cargo compartments of the aircraft. A configuration of five groups of packages, each having a different total TI value, with equal spacing distance S' between groups, is depicted in Fig. III.2. The highest radiation level for passengers would be at the seat directly above the centre group of packages.

III.18. For a configuration such as that shown in Fig. III.2, the inverse square law gives:

$$RDR = TF_f \sum_{i=1}^5 (TI_i/100)(1.0 + r_i)^2/(AMD_i)^2$$

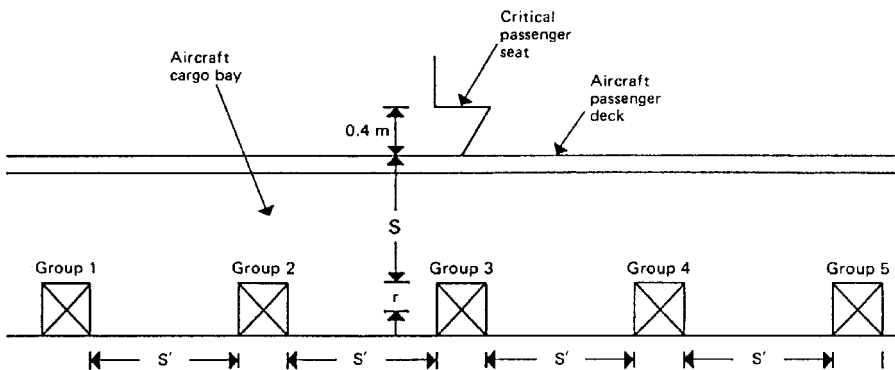

FIG. III.2. Typical configuration of passenger and special cargo in passenger aircraft, used for determining the segregation distance S and spacing distance S' .

III.19. If it is assumed that

$$TI_i = 4, i = 1 \text{ to } 5$$

$$r_i = 0.4 \text{ m}, i = 1 \text{ to } 5$$

$$TF_f = 0.7$$

then $RDR = 0.02 \text{ mSv/h}$. It is noted that

$$\begin{aligned} AMD_1 &= AMD_5 = \sqrt{(r + S + 0.4)^2 + (4r + 2S')^2} \\ AMD_2 &= AMD_4 = \sqrt{(r + S + 0.4)^2 + (2r + S')^2} \\ AMD_3 &= r + S + 0.4 \end{aligned} \tag{III.8}$$

III.20. Equations (III.7) and (III.8) combine to give one equation with two unknowns, S and S' . Various combinations of S and S' would allow a consignment of packages having a total TI of 20 to be carried with a segregation distance S less than 2.9 m. For example, placing the five groups, each with a total TI of 4, as shown in Fig. III.2, a segregation distance S of 1.6 m with a spacing distance S' of 2.11 m would give a maximum radiation level at seat height of 0.02 mSv/h. Thus various combinations of segregation and spacing would safely control the radiation exposure of passengers for large TI consignments.

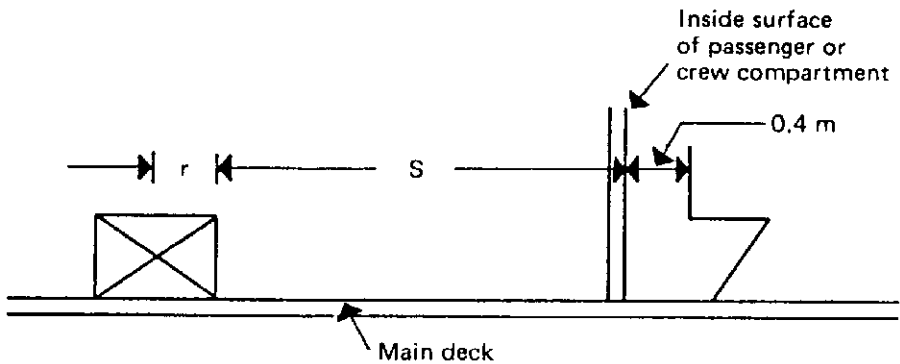

Fig. III.3. Typical configuration of main deck stowage on a combi or cargo aircraft.

TABLE III.3. VARIATION OF SEGREGATION DISTANCE WITH TRANSPORT INDEX FOR MAIN DECK STOWAGE ON A COMBI OR CARGO AIRCRAFT

Total of TIs for packages in the group	Horizontal segregation distance (from forward face of group of packages to inside wall of occupied compartment (m))
1.0	0.29
2.0	0.48
5.0	1.18
10.0	2.00
20.0	3.16
30.0	4.05
40.0	4.80
50.0	5.46
100.0	8.05
150.0	10.04
200.0	11.72

MAIN DECK STOWAGE ON COMBI OR CARGO AIRCRAFT

III.21. For this condition, all parameters previously assumed are used, except TF_w (transmission factor for the wall of an occupied compartment) is assumed (without verification) to be greater than or equal to 0.8.

III.22. For the crew, the following assumptions⁴ are made:

$$MATP = 1000 \text{ h/a}$$

$$RTF = 1/4$$

$$MAET = (1000 \text{ h/a}) \times (1/4) = 250 \text{ h/a}$$

$$DV = 5.0 \text{ mSv/a (from para. 306(a) of the Regulations)}$$

$$RDR = (5.0 \text{ mSv/a}) / (250 \text{ h/a}) = 0.02 \text{ mSv/h}$$

III.23. The MATP and MAET values used before for passengers in passenger aircraft are used here also. With these assumptions, the calculations for passengers in a combi and for crew in a cargo aircraft will result in the same segregation distances.

⁴ The values of MATP and RTF assumed here for crew members have not been verified for actual flight situations.

III.24. The situation for combi or cargo aircraft is depicted in Fig. III.3. The minimum horizontal distance between the seat back of a seated person and the inside wall of the occupied compartment is also assumed to be 0.4 m. This is probably a conservative value because, if the cargo is forward, the passenger's feet will be against the partition; and if the cargo is aft, there will usually be instruments, a galley, toilets or at least luggage or seat-reclining space between the partition and the rear seat. For this situation Eq. (III.3) applies for AMD, and

$$S = [(TI \times TF_w)/(100 \times RDR)]^{1/2} (1 + r) - (r + 0.4)$$

III.25. The calculated segregation distances for combi and cargo aircraft are shown in Table III.3.

SEGREGATION DISTANCES FOR UNDEVELOPED FILM

III.26. An approach similar to that described above may be used for determining segregation distance requirements for packages marked as containing undeveloped film. However, instead of modelling the time of exposure for repetitive trips, a single trip is considered. For this single trip a maximum allowed dose of 0.1 mSv, see para. 307, is normally used to calculate the segregation distance S for given transit times.

REFERENCES TO APPENDIX III

- [III.1] WILSON, C.K., The air transport of radioactive materials, *Radiat. Prot. Dosim.* **48** 1 (1993) 129–133.
- [III.2] GIBSON, R., *The Safe Transport of Radioactive Materials*, Pergamon Press, Oxford and New York (1966).
- [III.3] UNITED STATES ATOMIC ENERGY COMMISSION, *Recommendations for Revising Regulations Governing the Transportation of Radioactive Material in Passenger Aircraft* (July 1994) [available at the US Nuclear Regulatory Commission's Public Document Room, Washington, DC].
- [III.4] GELDER, R., *Radiological Impact of the Normal Transport of Radioactive Materials by Air*, Rep. NRPB M219, National Radiological Protection Board, Chilton (1990).
- [III.5] INTERNATIONAL CIVIL AVIATION ORGANIZATION, *Technical Instructions for the Safe Transport of Dangerous Goods by Air*, 1998–1999 Edition, ICAO, Montreal (1996).

Appendix IV

QUALITY ASSURANCE IN THE SAFE TRANSPORT OF RADIOACTIVE MATERIAL

INTRODUCTION

General aspects

IV.1. It is the aim of the Regulations to achieve, through the application of effective quality assurance and compliance assurance programmes, the safety of the public and workers in the transport of radioactive material.

IV.2. This appendix is based on the experience and requirements of a number of internationally accepted quality assurance standards and codes including the IAEA's Safety Series No. 50-C/SG-Q 1996 [IV.1] and ISO 9001 (1994) [IV.2], and more advice and supporting examples are contained in IAEA Safety Series No. 113 [IV.3]. It is expected that the radioactive material industry will use this appendix in the development of quality assurance programmes, as it is focused on their needs for relevant quality assurance. The previous version of this appendix, whilst not intended to be a quality assurance 'standard', was widely recognized and adopted by many Member States and industry as it specifically addressed the essential principles of quality assurance.

IV.3. Where organizations do not have quality assurance programmes or have quality assurance programmes based upon the framework of the 1985 edition of the IAEA Regulations, consideration should be given to developing the programme for transport activities to the structure shown in this appendix. Supported by Safety Series No. 113 [IV.3] it provides the principles and objectives to be adopted both when establishing a satisfactory overall quality assurance programme solely for the transport of radioactive materials and when adding to an existing quality assurance programme to cover specifically those parts of the organization's responsibilities that relate to the transport, frequent or infrequent, of radioactive material. The principles in each case for each type of programme are the same and are to ensure that all requirements applicable to the package and shipment are properly met and that this can be demonstrated to any competent authority at any time during the useful life of a package.

IV.4. The quality assurance principles described in this appendix may in many cases be implemented by one or more organizations, depending upon the arrangements within individual Member States. Such variations will be due to differing national regulatory

requirements, the general organization of industry, and the degree of complexity and experience of the technical organizations involved in transporting radioactive materials. In any event, the basic intent of the principles should be kept in mind at all times, and the detailed implementation procedures should be arranged accordingly.

IV.5. Quality assurance programmes are required for all radioactive material packages and operations, not just those subject to competent authority approval. When issuing approvals, competent authorities are required by the IAEA Regulations to include a specification of the applicable quality assurance programme in their certificate. Quality assurance programmes related to competent authority approved material and packages are subject to review and audit by competent authorities. Similarly quality assurance programmes covering radioactive material transport packages and operations not subject to competent authority approval should also be subject to review and audit by the responsible organization. All organizations involved should give reasonable assistance to competent authorities and their agents in this work.

IV.6. In the review of the earlier edition of Appendix IV the section headed “Control of Use and Care of Packages” was removed, and more appropriate parts of the quality assurance programme elements were revised to cover the important issues. This significant change brings this edition of the appendix more into harmony with the accepted quality assurance standards in use worldwide.

IV.7. This appendix was drafted in 1996, acknowledging current quality assurance standards and references. As developments in quality assurance occur, and such standards evolve, the advice in this appendix should be reviewed and applied taking into account such developments in quality assurance definition and practice.

Scope

IV.8. Quality assurance programmes should be established for the design, manufacture, testing, documentation, use, maintenance and inspection of special form radioactive material, low dispersible radioactive material and packages, and for transport and in-transit storage operations, and safety assessment to ensure compliance with the relevant provisions of the IAEA Regulations, irrespective of whether competent authority approval of the design or shipment is required. All activities such as cleaning, assembly, testing, commissioning, inspecting, maintaining, repairing, loading, transport, unloading, modifying and decontamination should be covered.

IV.9. The principles and objectives are applicable to all those responsible for the transport of radioactive materials, and to other organizations participating in activities affecting quality.

Responsibility

IV.10. The overall responsibility for the establishment and implementation of quality assurance programmes rests with the consignor, carrier or licensee/applicant for competent authority approval when appropriate. Some duties may be delegated to other organizations or persons within the responsibility of the above mentioned parties.

IV.11. If it is not possible according to individual national practices to clearly identify one responsible party or organization, the constituent parts and interfaces of an overall quality assurance programme must be clearly understood, documented and agreed by all parties including competent authorities when appropriate.

Quality assurance — Basic elements

IV.12. This section introduces the various elements to be addressed in a quality assurance (QA) programme, listed in Table IV.1, which should ensure compliance with applicable standards and regulatory requirements. It should be emphasized that not all of the elements listed in the table will be applicable in every case, depending on the nature of the activity carried out by the responsible organization. However, there are certain minimum requirements in terms of the elements of QA that must be addressed by any QA programme depending on the type of organization and its transport activity, and details of these are given in Table I of Safety Series No. 113 [IV.3]. In some Member States a quality assurance programme is referred to as a quality assurance system or quality system.

IV.13. It is the prime responsibility of any organization management to develop, implement and maintain its QA programme. An overall quality assurance programme should be established consistent with the requirements of this appendix and covering the various aspects of the safe transport of radioactive materials, e.g. packaging, packing, handling, storage and training of personnel. The programme should be commensurate with the complexity of the packaging, its contents and components, or the actual transport operation. The degree of hazard associated with the contents that may be carried combined with a graded system of quality assurance measures should also influence the development of the quality assurance programme. Further guidance on a 'graded approach' is given in the appendix to Safety Series No. 113 [IV.3]. Items, activities and processes to which quality assurance programmes apply should be identified and appropriate methods or levels of control and verification assigned consistent with their importance for safety.

TABLE IV.1. BASIC ELEMENTS OF QUALITY ASSURANCE PROGRAMMES THAT SHOULD BE CONSIDERED AND ADDRESSED IN THE SAFE TRANSPORT OF RADIOACTIVE MATERIAL

QA programme
Organization
Document control
Design control
Procurement control
Material control
Process control
Inspection and test control
Non-conformance control
Corrective actions
Records
Staff training
Servicing
Audits

IV.14. The QA programme should not only provide for the work supporting the safe transport of radioactive material to be carried out in a quality assured manner, but also for the necessary management measures to be in place to control and maintain the programme.

IV.15. All programmes should ensure that the activities affecting quality are accomplished in accordance with written arrangements, instructions or drawings of a type appropriate to the circumstances, and that they include appropriate quantitative and/or qualitative acceptance criteria for determining that important activities have been satisfactorily accomplished.

IV.16. Procedures for implementing the quality assurance programmes on a planned and systematic basis should be developed and documented by the organization performing the constituent activities. All measures established (see paras IV.2–IV.15) should be adequately documented and steps taken to ensure that persons performing the quality assurance function have an adequate knowledge of the language in which the programme is written. Translations of the documentation into other languages should be verified by competent persons referring to the original.

IV.17. The quality assurance programme should be subject to regular review by the management relative to the activities for which they have responsibility. Measures should be included to remedy any deficiencies discovered or to introduce any improvements recommended.

QUALITY ASSURANCE PROGRAMMES

Organization and structure of the quality assurance programme

IV.18. The quality assurance programme should be prescribed in a document describing the structure and overall composition of the quality programme. The document should include or make reference to the necessary procedures and/or instructions, and describe the way in which they combine to form the overall quality programme. The programme should cover all activities of the company related to the safe transport of radioactive materials and compliance with the IAEA Regulations.

IV.19. Included in the quality assurance programme must be the company's quality policy statement which clearly reflects the commitment of senior management to the attainment and continuous improvement of quality, and to compliance with applicable regulations.

Documenting the quality assurance programme

IV.20. All constituent parts of the quality assurance programme developed and maintained by the company should be systematically produced in the form of appropriate written documents.

IV.21. Documentation of the quality assurance programme should be structured so that it is appropriate to the size and complexity of the company and the work it performs, and is readily understood by users.

Review and evaluation of the quality assurance programme

IV.22. Provision should be made by the company management for periodic review and evaluation of the quality assurance programme. These reviews should ensure that the quality assurance programme continues to be effective and appropriate to the

company's activities, and that the quality policy objectives continue to be met. The results of such reviews should be documented and appropriate action taken by company management.

ORGANIZATION

Responsibility and authority

IV.23. A clearly defined and documented organizational structure, complete with functional responsibilities, levels of authority and lines of internal and external communication, should be established. The organizational structure and functional assignments should recognize that application of a quality assurance programme is the responsibility of management, of those performing the work and of those verifying the effectiveness of the management processes involved. It is binding on everyone and is not the sole domain of any single group. The organizational structure and the functional assignments should be such that:

- (a) Attainment of quality objectives is accomplished by those who have been assigned responsibility for performing the work; this may include examination, checks and inspections of the work by the individuals performing the work; and
- (b) When verification of conformity to established requirements is necessary, it is carried out by those who do not have direct responsibility for performing the work.

IV.24. The persons and organizations ensuring that an appropriate quality assurance programme is established and effectively applied should have sufficient authority and organizational freedom to identify quality problems, to review all pertinent information and to initiate, recommend or provide solutions. Such persons or organizations should also have the authority to initiate actions to control further processing, delivery, installation or use of an item, package, process, or part of the quality assurance programme which is non-conforming, deficient or unsatisfactory until proper compliance has been achieved. They should be sufficiently independent of cost and schedule considerations.

Contract review

IV.25. Documented procedures should be established to ensure that contracts, orders or tenders placed between those different participating organizations in transport are reviewed for their adequacy and accuracy; any subsequent changes

should be similarly reviewed and passed to the relevant parts of those organizations concerned.

Organizational interfaces

IV.26. The quality assurance programme and associated procedures should provide for the documented recognition and control of interfaces, both internal and external, wherever they occur.

IV.27. Where several organizations are involved in a transport operation, the responsibility of each organization should be clearly established, and interfaces and co-ordination among organizations should be achieved by appropriate measures, with provision made for regular review and amendment when necessary.

DOCUMENT CONTROL

Document preparation, review and approval

IV.28. The preparation, review, approval and issue of documents essential to the performance and verification of the work, such as instructions, procedures and drawings (these may be held in hard copy or other media such as computer disk or microfilm), concerned with all activities affecting quality of design, manufacture, use, etc., of the packaging and transport operations, should be subject to control. Instructions, procedures and drawings should include appropriate qualitative and quantitative acceptance criteria for determining that important activities have been satisfactorily accomplished. Documents should be independently (of the original author) reviewed to ensure they meet the company's technical and quality requirements, and should be approved prior to release. Individuals and organizations responsible for document review and approval should be clearly identified and should have the necessary authority.

Document release and distribution

IV.29. Measures should be provided for ensuring that those participating in an activity are aware of, and use, appropriate and up to date documents for performing the activity.

IV.30. A document release and distribution system should be established to make the documents readily available by means of up to date distribution lists or other methods appropriate to the complexity of the company and its activities.

Document change control

IV.31. Changes to documents should be identified and recorded, and should be subject to review and approval, in accordance with documented procedures, by the original document review and approval functionaries or other designated persons or organizations having access to the relevant information. Distribution of revised documents, and information concerning their status, should be prompt and timely. Care should be taken to ensure that out of date, redundant documents are destroyed or clearly marked as such to prevent further use. When necessary an original document file should be established to maintain the history and to assure traceability; these documents should be marked as obsolete to prevent any further use.

DESIGN CONTROL

General

IV.32. Design control measures should be established and documented to ensure that all design requirements are identified, specified and met by the final design.

IV.33. Where the design process involves more than one organization or function, appropriate interfaces and responsibilities should be established and documented in order to maintain the required design control (see also para. IV.25).

Design planning

IV.34. The organization responsible for the design process should establish and review appropriate plans for those design activities to be carried out, assigning responsibilities, personnel and resources as necessary.

Design input

IV.35. Design input requirements such as regulatory requirements, quality requirements, design bases, codes, standards, specifications, drawings, results of contract reviews, etc., should be identified, documented and reviewed to ensure that they are sufficient for the final design. They should include, where applicable, quantitative and qualitative acceptance criteria.

IV.36. Measures should also be established for the selection and for the review for suitability of materials, parts, equipment and processes that are essential to the

function of the packaging, subassembly, systems or components relative to their operating environments.

Design output

IV.37. Design output, as the final product of the design process, should be documented to demonstrate its conformance to the agreed design input requirements and to the defined acceptance criteria. It should be reviewed and approved by the defined level of management in the company or organization responsible for the design. Design output documents may include drawings, specifications, handling and maintenance instructions, etc., and can be in the form of hard copy, electronic data or other acceptable media. Other parties such as the end user, customer, manufacturer or the regulatory body may comment on design output and influence its final approval.

Design verification and validation

IV.38. Design control measures should be established and documented for verifying the adequacy of design, by the performance of design review(s). Design reviews and verification can be supported by the use of alternative calculation methods, or by the performance of a suitable test programme in accordance with the requirements of the IAEA Regulations as appropriate.

IV.39. Design verification and review should involve all functions or personnel concerned with the final design quality and/or the design phase under consideration.

IV.40. Design validation activities should be carried out as necessary to confirm that the finished item, packaging or service conforms to the end user's requirement. This can be done by means of commissioning tests, package handling trials or similar methods.

IV.41. The results of all these design activities should be appropriately recorded in order to demonstrate control throughout the design process and confirm that the finished design meets all requirements.

Design changes

IV.42. Procedures should be established for effecting design changes, including in-service changes or modification, in a manner consistent with the design control measures for the original design. Design changes should be approved by the original design organization/function or a technically qualified substitute. The full impact of changes should be carefully considered and the need, justifications and required

actions recorded. Written information concerning the changes should be sent to all affected persons and organizations in a controlled and timely manner.

PROCUREMENT CONTROL

General

IV.43. Procurement control measures should be documented and ensure that purchased items and services meet defined requirements and performance criteria.

IV.44. Items or services may be procured to different levels of quality, depending on their importance and impact on safety. A graded approach to quality, as described in Safety Series No. 113 [IV.3], may be used in the procurement of such items and services.

Supplier evaluation and selection

IV.45. Supplier evaluation procedures as part of the procurement process should ensure that only suitably qualified suppliers are selected and used. The selection of suppliers should be based on their evaluated and documented capability to provide items or services in accordance with the requirements of the procurement documents, and should take account of the type of product and its impact on the quality of the final product or service. Appropriate records of evaluation and supplier selection should be maintained.

Purchasing data

IV.46. Purchasing documents should contain data clearly describing the product or service required; such documents should be reviewed and approved before release. These data may include reference to applicable regulatory requirements, standards or codes, drawings, specifications, quality and other requirements as necessary.

Purchasing verification

IV.47. Purchasing verification measures should provide for agreement between the supplier and the purchaser on methods used to verify that all purchasing requirements will be met. Where verification of the purchased product will be performed at the subcontractor's premises, the verification arrangements should be clearly specified in the purchasing documents. The supplier, competent authority (when necessary), or their representatives, should have access to plant facilities, items, materials and

records for inspection and audit and have appropriate records forwarded when required for review or approval. These records should be retained for an appropriate time.

IV.48. Verification that the purchased product conforms to the requirements is the prime responsibility of the supplier. In the case of a purchased packaging, the purchaser should obtain adequate documented evidence that the packaging has been designed, manufactured and tested to meet specified requirements, and that acceptable national or international standards on quality assurance have been applied throughout. Where the customer, end user or competent authority verify the product at the subcontractor's or the supplier's premises, this verification should not replace responsibility of the supplier for effective control.

Purchaser supplied material

IV.49. Documented procedures should be established to ensure that any material or equipment provided by the purchaser, for use in the final product or service, is suitably protected and controlled by the supplier.

MATERIAL CONTROL

IV.50. Measures should be established and documented for the identification and control of packagings, package contents, associated transport equipment, materials and components; these measures should cover all relevant phases of transport including the entire production process, handling, loading, labelling and despatch, carriage, receipt, servicing and maintenance, storage, etc.

IV.51. Similar measures should provide for sufficient traceability throughout the transport cycle, and also prevent damage, deterioration, loss, or the use of time expired material. Records of identification and traceability should be appropriately maintained, detailing batch or individual item identity when required.

PROCESS CONTROL

General

IV.52. All processes involved in design, manufacture, use or servicing activities should be subject to documented control procedures. These process controls should be developed where the absence of such procedures would have an adverse effect on

quality or where the required quality cannot be verified by post-process examination. The training and qualification of personnel, when relevant to the process, should be specified or referenced in these control procedures. Where processes are verified by statistical sampling or similar techniques, the application of these techniques should be in accordance with documented procedures.

Process control — Transport

IV.53. Control of the transport operation as a process should be accomplished by documented procedures or quality plans. These procedures should cover, when applicable, identification and control of contents, packing, handling, labelling, despatch, carriage, receipt, cleaning, storage, servicing and maintenance, etc., and any special process controls, including monitoring of leaktightness, radiation and contamination levels relating to package material. These measures should also identify relevant interfaces and their controls, prevent damage, deterioration or loss of contents, and enable compliance with the relevant regulations for packages or consignments to be confirmed.

IV.54. An example of a quality plan for the control of transport operations can be found in Safety Series No. 113 [IV.3].

Special processes

IV.55. Processes affecting the finished product/service quality, where the required quality cannot be verified by post-process examination alone, and where pre-qualification of the process is necessary, e.g. welding or heat treatment, should be controlled in accordance with documented procedures. Such procedures should refer to relevant codes, standards, specifications or dedicated requirements. Where specified, measures should be taken to ensure that these processes are accomplished by qualified personnel, procedures and equipment.

INSPECTION AND TEST CONTROL

General

IV.56. Documented procedures should provide for in-process, final, and in-service inspection carried out during all phases of testing, production, transport and maintenance against specified requirements. These procedures should include provision for measuring and test equipment used to be calibrated, adjusted and maintained at defined intervals.

IV.57. Test and inspection status of packagings or their parts should be identified by the use of markings, stamps, tags, labels, routing cards, inspection records, security seals or other appropriate means to indicate the acceptability or non-conformity of items. The identification of the inspection and test status should be maintained as necessary throughout manufacturing, use, servicing and maintenance of the item, to ensure that only items that meet the specified requirements are used.

Programme of inspection

IV.58. Receipt inspection, in-process inspection, and final inspection measures should be planned and carried out to meet the requirements specified in regulations, standards, design and manufacturing documents, transport, servicing, maintenance, and operating procedures, instructions, applicable quality plans, etc. Essential criteria to be included in such inspection measures can be found in Safety Series No. 113 [IV.3].

Test programme

IV.59. All testing required to demonstrate that the package, and its components, will perform satisfactorily in continued service should be carried out in accordance with documented procedures. Such testing may include prototype qualification and regulatory proof testing, production, operational, servicing and maintenance tests, etc. These procedures, incorporating the requirements and acceptance criteria specified in design documents, should be carried out by trained personnel using properly calibrated instrumentation and equipment. All test results should be recorded and evaluated to confirm that the defined requirements have been met.

Calibration and control of measuring and test equipment

IV.60. Documented measures should ensure that tools, gauges, instruments, test software and other inspection, measuring and test equipment, and other devices used in determining conformity to acceptance criteria, are of the proper range, type, accuracy and precision. They should be properly handled and stored, controlled, calibrated and adjusted at specified intervals to maintain accuracy. Records of calibration should be maintained and be adequate for traceability of measurement, to national or international standards, when necessary. When deviations beyond prescribed limits are detected, an evaluation should be made of the validity of previous measurements and tests, and acceptance of tested items reassessed.

NON-CONFORMITY CONTROL

IV.61. Documented measures should control items such as packagings, package contents, services and processes which do not conform to requirements, in order to prevent their inadvertent use before or during transport. These measures should also ensure that non-conforming items be identified by marking, tagging and/or by physical segregation, where practical, in order to control further processing, delivery or assembly. Such items should be reviewed and rejected, modified, repaired, reworked or accepted without modification. The responsibility for review and authority for disposal or acceptance of non-conforming items should be defined.

CORRECTIVE ACTIONS

IV.62. Documented procedures should provide for corrective and preventive action to ensure that conditions adverse to quality, such as failures, malfunctions, deficiencies, deviations, defective or incorrect material and equipment, and any other non-conformities, are promptly identified, corrected and prevented from recurring. Such procedures should provide for:

- investigation and determination of the root causes of non-conformities and of corrective actions required to prevent their recurrence;
- processing of customer, regulator or other complaints, and appropriate responsive or corrective action;
- controls to ensure that corrective action is promptly implemented and effective;
- detection of potential quality failures and the identification of appropriate preventive action.

IV.63. Corrective and preventive action reports should be documented and provided to appropriate levels of management in order to support management review and quality improvement.

RECORDS

IV.64. Documented procedures for the identification, collection, indexing, filing, storage, maintenance, retrieval and disposal of pertinent quality documentation and records should be established. Records should demonstrate that the product or service has met the specified requirements, and that the quality assurance programme is operating effectively. Such records should be retained for defined periods, be readily

retrievable and maintained in good condition. They may take the form of hard copy, electronic data or any other acceptable media.

IV.65. Records relating to appropriate radioactive material packagings should be established and maintained to record the complete manufacturing, operational and service/maintenance history of such packagings.

IV.66. Further guidance and examples of what may constitute general quality or package specific records can be found in Safety Series No. 113 [IV.3].

STAFF AND TRAINING

IV.67. All personnel responsible for performing activities affecting quality should be suitably trained and qualified to perform their specifically assigned tasks.

IV.68. Documented procedures should provide for the identification of training needs and training programmes, including, when necessary, specialist qualification training; records of training should be maintained.

SERVICING

IV.69. Documented measures should be established to control all servicing and maintenance activities relative to packaging, transport related equipment and other items, in order to ensure continued compliance with specified requirements. Servicing and maintenance schedules should be based on design input and experience, and also take account of normal or harsh operating conditions. The measures should provide for the identification of specified requirements, confirm that they have been met, and produce the necessary records.

AUDITS

IV.70. Documented procedures should ensure that internal audits are carried out on a regular basis to verify compliance with all aspects of the quality assurance programme and to confirm its continuing effectiveness. Similarly, when conducting external audits, to verify the quality arrangements of suppliers, they should be planned and carried out in accordance with written procedures. Audits should be conducted by qualified persons selected for their independence from the activity under audit.

IV.71. The documented audit results should be brought to the attention of the management personnel responsible for the activity audited. The responsible management should take timely improvement or corrective action in response to the audit findings. Verification of the effective implemented corrective action should be established and recorded.

IV.72. Further guidance on the various phases of audits such as audit programme elements, audit scheduling, team selection, pre- and post-audit meeting, reporting and response, and follow-up action can be found in Safety Series No. 113 [IV.3].

DEFINITIONS OF TERMS USED IN APPENDIX IV

IV.73. For the purposes of Appendix IV, the following terms, as defined in the Regulations, apply:

Carrier — See para. 206 of the Regulations.

Competent authority — See para. 207 of the Regulations.

Compliance assurance — See para. 208 of the Regulations.

Consignor — See para. 212 of the Regulations.

Design — See para. 220 of the Regulations.

Quality assurance — See para. 232 of the Regulations.

IV.74. For the purposes of Appendix IV, the following terms, as defined in Safety Series No. 113 [IV.3], apply: applicant, assessment, audit, controlled document, corrective action, design input, design output, examination, inspection. Item, maintenance/servicing, measuring and test equipment, non-conformance, objective evidence, procedure, procurement document, qualification, quality, quality elements, quality assurance programme, quality plan, repair, services, specification, supplier, traceability, user, and verification.

IV.75. The following definitions are intended only for the interpretation of the terms as used in this Appendix IV:

Certification — The act of determining, verifying and attesting in writing to the qualifications of personnel, processes, procedures or items in accordance with specified requirements.

Documentation — Recorded or pictorial information describing, defining, specifying, reporting or certifying activities, requirements, procedures or results related to quality assurance.

Logbook — A document which contains references to the history and status of packagings.

Qualified person — A person who, having complied with specific requirements and met certain conditions, has been officially designated to discharge specified duties and responsibilities.

Records — Documents which furnish objective evidence of the quality of items or services and of activities affecting quality, by means of which it may be determined whether the specified requirements are satisfied.

Responsible organization — The organization/party/person having overall responsibility for one or more areas of transport (e.g. approval, manufacturing, shipment, in-transit storage).

Transport — All operations and conditions associated with, and involved in, the movement of radioactive material; these include the design, manufacture, maintenance and repair of packaging, and the preparation, consigning, loading, carriage including in-transit storage, unloading and receipt at the final destination of consignments of radioactive material and packages.

REFERENCES TO APPENDIX IV

- [IV.1] INTERNATIONAL ATOMIC ENERGY AGENCY, Quality Assurance for Safety in Nuclear Power Plants and other Nuclear Installations, Safety Series No. 50-C/SG-Q, IAEA, Vienna (1996).
- [IV.2] INTERNATIONAL ORGANIZATION FOR STANDARDIZATION, Quality Systems — Model for Quality Assurance in Design Development, Production, Installation and Servicing, ISO 9001-1994(E), ISO, Geneva (1994).
- [IV.3] INTERNATIONAL ATOMIC ENERGY AGENCY, Quality Assurance for the Safe Transport of Radioactive Material, Safety Series No. 113, IAEA, Vienna (1994).

Appendix V

PACKAGE STOWAGE AND RETENTION DURING TRANSPORT

INTRODUCTION

V.1. In order for radioactive packages to be transported safely, such package should be restrained from movement within or on the conveyance during the transport operation, as required by the IAEA Regulations. The particular requirements of the relevant paragraphs of the Regulations apply in the following ways:

- para. 564: secure stowage of consignments — this can be ensured by a variety of retention systems (see below);
- para. 606: each package shall be designed with due consideration being given to its retention systems relevant to each intended mode of transport;
- para. 612: the components of the package and its retention systems shall be designed so that their integrity will not be affected during routine operations;
- para. 636: the integrity of the package (IP-3 to Type C) shall not be impaired by the stresses imposed on the package or its attachment points by the tie-downs or other retention systems in either normal or accident transport conditions.

V.2. Some aspects relating to these paragraphs in the Regulations are noted in their respective advisory paragraphs in the main text of this publication, but additional detail is contained in this appendix and in Refs [V.1–V.27]. Package retention systems only have to be designed to meet the demands of routine conditions of transport. Therefore, in normal or accident conditions of transport, the package is permitted, and may be required as part of the design, to separate from the conveyance by the breakage or designed release of its restraint in order to preserve the package integrity. The inertial forces that act on the packages during routine conditions of transport can be derived from uneven road or track, vibration, linear accelerations and decelerations, direction changes, road skids in inclement weather that do not result in impact, rail shunting, heavy seas, and turbulence or rough landings in air transport.

TYPES OF RETENTION SYSTEM

V.3. Frequently, the method of retention incorporates the use of tie-downs, but there is a range of methods of restraint that can be adopted, as follows:

- tensile tie-downs or lashings (straps, ropes, chains, etc.) connected between attachment points on the package and anchor points on the conveyance;
- tensile tie-downs, nets or lashings thrown over the top of the package and secured only to the conveyance (i.e. no attachment points on the packaging);
- trunnions on the package secured to bearers that are either on a transport frame or form part of the conveyance;
- feet or baseplate flanges, integral with the package, that are bolted either to a transport frame or directly to the conveyance;
- standard or heavy duty ISO twistlocks;
- chocks attached to the conveyance, or a stillage attached to the conveyance, or a recess (e.g. a well) manufactured into the conveyance, by which the package is restrained by its own weight.

V.4. Some of these methods of retention can be combined if required, in the same way that packages are recommended to be chocked as well as being tied down. The methods of retention should not cause the package to be damaged, or even stress components of the package or its retention system beyond yield, during routine conditions of transport. The requirement that the integrity of the package should not be impaired by overstressing in normal or accident transport conditions can be satisfied by the designer incorporating quantifiable weak links in either the package attachment points or in the tie-downs specified for restraint.

V.5. Frequently, larger and heavier packages are secured to the conveyance by means of a dedicated method of retention. Lightweight and small packages are generally carried in a closed conveyance and are blocked, braced, tied down or otherwise appropriately restrained for transport. Dedicated package retention equipment should be identified and specified during the package design, and operating and handling instructions should be drawn up for the use of the package and its retention equipment. In the absence of such dedicated equipment, the consignor and the carrier have the responsibility to ensure that the movement of the package is conducted in compliance with the regulatory and transport modal requirements, e.g. by the use of general purpose tie-downs or cargo nets.

V.6. Tensile tie-downs are a very commonly used method of package retention, and the following practical aspects of their use should be noted:

- Chocks fastened to the conveyance, and abutting the base of the package to restrict its horizontal movement, greatly reduce the loading imposed on the tensile tie-downs, as well as ameliorating the instantaneous dynamic loading, thereby giving the tie-downs a critical additional time to stretch uniformly rather than snapping prematurely.

- The angle formed by tie-down members with the conveyance when viewed from the side and above should be close to 45° in order to resist efficiently the potential forces in all three directions (longitudinal, lateral and vertical). If the package is large in relation to the size of the conveyance, the tie-down members may be crossed to achieve the nominal 45° restraint angles. Rubbing of tie-down members on each other or on parts of the package or conveyance should be prevented. For a non-symmetrical package, the tie-down angles should be modified to take account of the package geometry.
- Tie-down members should be pre-tensioned to avoid slackening during use, and should be checked and maintained throughout the journey. Potential loosening by vibration during transit should be avoided by the use of vibration resistant connections.
- Tie-down anchor points (and chocks) should be fastened directly to the frame of the conveyance and not to the platform, unless the platform is capable of withstanding the specified design forces.

PACKAGE ACCELERATION FACTOR CONSIDERATIONS

V.7. Because of the differences in transport infrastructures and practices throughout the world, the national competent authorities and the national and international transport modal standards and regulations need to be consulted to confirm the mandatory or recommended package acceleration factors, together with any special conditions for transport, which should be used in the design of the packages and their retention systems. These acceleration factors represent the package inertial effects and are applied at the package mass centre as equivalent static forces, against which the package retention system should be designed. Since many packages are designed for use in more than one country and with more than one transport mode, the most demanding acceleration factors applicable in the relevant countries and transport modes should be used.

V.8. Acceleration factors will need to be applied in the design and analysis of packages and their retention systems. Table V.1 gives an indication of the magnitude of the acceleration factors which might be used for the design of the package and its retention system for routine conditions of transport. The values given for each mode would be in accordance with most national and international regulations. It is incumbent upon the package designer and user to ensure that the package retention system was designed in compliance with those values specified by the relevant competent authorities and transport modal organizations.

TABLE V.1. ACCELERATION FACTORS FOR PACKAGE RETENTION SYSTEM DESIGN

Mode	Acceleration factors		
	Longitudinal	Lateral	Vertical
Road	2g	1g	2g up, 3g down
Rail	5g	2g	2g up, 2g down
Sea/water	2g	2g	2g up, 2g down
Air ^a	1.5g (9g forward)	1.5g	2g up, 6g down

^a The vertical acceleration factor for air depends on the pitch acceleration of the type of aircraft when subjected to the maximum gust conditions and the position of the cargo relative to the aircraft centre of gravity. The values shown are the maxima for most modern aircraft. The 9g forward longitudinal factor is required when there is no reinforced bulkhead between the cargo space and the aircraft crew.

V.9. In addition to these quasi-static force considerations, the package designer must also account for the effects of fluctuating loads which could lead to the failure of components of the package and its retention system caused by fatigue. Further consideration should be given to the ability of the package and its retention system to withstand the effects of wear, corrosion, etc., over their envisaged design lives. All structural design criteria, including the design stresses for both strength and fatigue, used in the design of the package and its retention system should be agreed with the relevant competent authorities. In particular, the accelerations derived from routine conditions of transport should not cause any component of the package or its retention system to yield, whereby repeated use in transport operations would result in incremental damage which could lead to premature failure.

V.10. The forces imposed on the package may be determined by multiplying the acceleration factors by the mass of the package. For vertical accelerations, the factors are those experienced by the package, not allowing for gravity.

V.11. It should also be noted that, for some specific packages, there have already been agreements with many competent authorities and the transport modal organizations that different acceleration factors may be used. Table V.2 details a limited number of such packages, and other examples can be found in the references [V.1–V.27], see in particular Refs [V.10–V.12]. The acceleration values quoted in Table V.2 are as depicted in the appropriate references, and may not be absolute accelerations. The source documents should be referred to for clarification. It is still incumbent upon the

TABLE V.2. ACCELERATION FACTORS FOR PACKAGE RETENTION SYSTEM DESIGN FOR SPECIFIC PACKAGES

Type of package	Mode	Acceleration factors		
		Longitudinal	Lateral	Vertical
Certified fissile and Type B packages in the USA [V.7]	All	10g	5g	2g
Radioactive materials packages in Europe by rail (UIC) [V.8]	Rail	4g (1g ^a)	0.5g ^a	1g ± 0.3g ^a
Carriage of irradiated nuclear fuel, plutonium and high level radioactive wastes on vessels [V.9]	Sea	1.5g	1.5g	1g up, 2g down
Domestic barge transport of radioactive materials packages [V.6]	Sea/water	1.5g	1.6g	2g
Uranium hexafluoride packages [V.1]	Road and rail	2g	1g	± 1g
	Sea	2g	1g	± 2g
	Air	3g	1.5g	± 3g

^a Lower acceleration factors are allowed if dedicated movements with special rail wagons are made. Additionally, higher acceleration factors are required if snatch lifting on the attachment points is likely to occur, or if the rail wagons are to be carried on certain roll-on/roll-off ferries [V.8].

package designer and user to liaise with competent authorities outside these agreements to confirm that these factors will be acceptable for the proposed transport operations.

DEMONSTRATING COMPLIANCE THROUGH TESTING

V.12. It may be desirable to demonstrate, through testing, that a package and its retention system satisfies the acceleration factor requirements. When acceleration sensors are used to evaluate retention system behaviour, the cut-off frequency should be

considered relative to defining equivalent quasi-static loads. The cut-off frequency should be selected to suit the mass, shape and dimensions of the package and the conveyance under consideration. Experience suggests that, for a package with a mass of 100 t, the cut-off frequency should be of the order of 10–20 Hz [V.8]. For smaller packages with a mass of m t, the cut-off frequency should be adjusted by multiplying by a factor of $(100/m)^{1/3}$.

EXAMPLES OF RETENTION SYSTEM DESIGNS AND ASSESSMENTS

V.13. Many designs are used for providing package retention within or on conveyances, and two are illustrated here:

- (1) the use of tensile tie-downs with chocks, and
- (2) a rigid package baseplate/flange bolted to the conveyance.

V.14. These are based on the calculated examples given in various references at the end of the appendix, see especially Refs [V.3, V.11, V.17]. Friction between the package and the conveyance platform is to be ignored and can only be regarded as a bonus giving an additional but unquantifiable margin of safety.

V.15. Precise calculations of the loads generated by and in retention systems arising from accelerations assumed to act simultaneously in different directions are analytically complex, the analysis becoming increasingly so with multiredundant retention systems. Nevertheless, the designer is required to quantify the loading being passed from the restraint system to the package and conveyance (by reaction). Such a quantification is necessary on several counts:

- (i) to identify maximum package retention attachment loads;
- (ii) to ensure that, under some acceleration envelope, the restraint system is properly specified and the package location is properly maintained;
- (iii) to identify maximum conveyance anchor loads;
- (iv) to demonstrate to any relevant competent authority that the package integrity is maintained as required by Safety Standards Series No. ST-1;
- (v) to allow proper specification of stowage instructions (to a carrier); and
- (vi) to clearly identify criteria by which the restraint system components and attachments design comply with the above considerations.

V.16. To show the level of consideration required, even for simple statically determinate retention systems, the following two examples, with their simplifying assumptions, are presented.

Tensile tie-down system with chocks

V.17. Consider a rigid package restrained by four symmetrically disposed tension tie-downs. A requirement of the simplified method is to predict upper bound values of tie-down force and hence, by reaction, forces on the package attachment and the conveyance. This method is applicable only to statically determinate systems, and simple iterative assumptions are made on the system behaviour to derive upper bound forces.

V.18.A cubic package of mass M is depicted in Fig. V.1. All dimensions, X , Y , and Z , are equal and the centre of gravity is at the point $X/2$, $Y/2$, $Z/2$. The angles ϕ are equal and in the vertical plane of the tie-down member. Similarly the angles α in the horizontal plane are equal. The package is restrained symmetrically by four tie-down members, 1, 2, 3, and 4, as shown in Fig. V.1. The tensions in the ties are, respectively, P_1 , P_2 , P_3 and P_4 . The package accelerations are a_x , a_y and a_z .

V.19. The package, if acted upon by absolute accelerations a_x , a_y and a_z , will have forces F_x , F_y , F_z (of magnitudes Ma_x , Ma_y , Ma_z , respectively) and a body force F_g (of

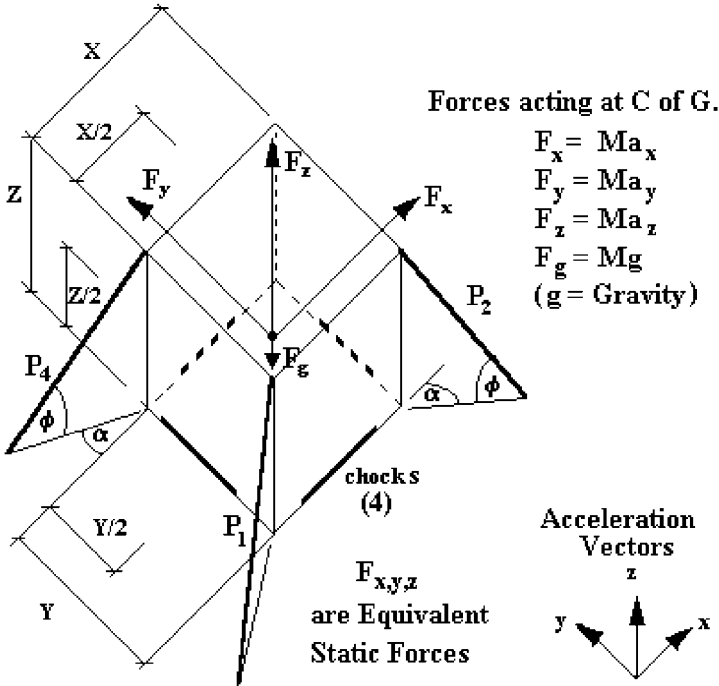

FIG. V.1. Graphical depiction of tensile tie-down system with chocks.

magnitude Mg) acting at the centre of gravity. For this example, it is assumed that, at the instant before these forces are applied, the pre-tension in all ties (P_1 , P_2 , P_3 and P_4) approaches zero, i.e. the ties are just 'tight'.

V.20. Consider the force F_x acting alone: only tie-down members P_1 and P_4 resist this force by tension, since ties P_2 and P_3 are ineffective in compression. Consider the force F_y acting alone: by the same argument as above, only ties P_1 and P_2 resist this force by tension.

V.21. Consider the forces F_x and F_z acting together: the rigid package has a tendency to tip about its bottom edge, and tie-down members P_1 and P_4 resist this by tension. Consider also the forces F_y and F_z acting together: tie-down members P_1 and P_2 resist this tipping tendency by tension. The symmetry of this example assures that the pairs of tensile tie-downs, as identified above, carry equal loading.

V.22. To calculate an upper bound tie-down member tension, consider the forces F_x and F_z acting together and the package just on the point of tipping about its bottom edge. Taking moments about this edge, the following is obtained:

$$F_x (Z/2) + F_z (X/2) = F_g (X/2) + 2ZP_{1x} (\cos \phi \cos \alpha) + 2XP_{1x} \sin \phi$$

V.23. Since $Z = X$, $F_x = Ma_x$, $F_z = Ma_z$ and $F_g = Mg$, P_{1x} is determined by:

$$P_{1x} = [M(a_x + a_z - g)]/[4(\cos \phi \cos \alpha + \sin \phi)]$$

V.24. Similarly, for the forces F_y and F_z acting together and the package just on the point of tipping about its bottom edge, the following is obtained:

$$P_{1y} = [M(a_y + a_z - g)]/[4(\cos \phi \cos \alpha + \sin \phi)]$$

V.25. The maximum tie-down load for road transport can be calculated by assuming that $P_1 = P_{1x} + P_{1y}$ and that $a_x = 2 g$; $a_y = 1 g$; $a_z = 2 g$; and $\alpha = \phi = 45^\circ$. Hence:

$$P_1 = 0.621 Mg + 0.414 Mg = 1.035 Mg$$

V.26. It should be noted that combining P_{1x} and P_{1y} as above is conservative since in deriving P_{1x} and P_{1y} each value has used $(a_z - g)$ in solving the moment equilibrium of the system.

V.27. In general, the geometry of the package, or the asymmetry in the horizontal acceleration factors to be used, will dictate about which edge the package will tend to

tip, and the calculation can then ignore the superimposition of the two horizontal forces in deriving the retention system requirements.

V.28. To calculate the maximum chock loads, the calculated horizontal force on the chocks will be maximum if the effects of friction between package base and conveyance floor are neglected. Friction values are difficult to quantify, and may be zero if the applied vertical acceleration were sufficient to overcome gravity effects.

V.29. To maximize the horizontal chock forces, each direction can be investigated by assuming only an acceleration force in the horizontal plane. Consider F_x acting when $F_z = F_g$. The package is restrained from sliding by tie-downs 1 and 4, and the chock on the opposite side. From symmetry $P_{1x} = P_{4x}$ and at the instant of sliding and tipping, the following is obtained for horizontal equilibrium:

$$F_x = 2P_{1x}(\cos \phi \cos \alpha) + F_{cx}$$

where F_{cx} is the force on the chock; which becomes, on substituting Ma_x for F_x , $F_{cx} = Ma_x - 2P_{1x}(\cos \phi \cos \alpha)$.

V.30. However, from before,

$$P_{1x} = [M(a_x + a_z - g)]/[4(\cos \phi \cos \alpha + \sin \phi)]$$

So, for $a_x = 2g$, $a_z = 1g$, no friction, and $\phi = \alpha = 45^\circ$, this gives:

$$F_{cx} = 1.586 Mg$$

V.31. Similarly, for the chock force F_{cy} , with $a_y = 1g$; $a_z = 1g$; and $\phi = \alpha = 45^\circ$,

$$F_{cy} = 0.793 Mg$$

V.32. It should be noted that different combinations of accelerations may have to be considered to derive maximum loading consequences on the tie-downs and chocks, i.e. an iterative approach is needed for the ultimate solution.

V.33. It is apparent from the above example that there are significant forces being taken by the chocks. In the absence of such chocks, the only means of package retention is from the tie-down restraints, and the tie-down members will have, as soon as the accelerations to be considered exceed rather low values, to be prestressed and to be capable of withstanding forces much greater than those calculated when chocks are

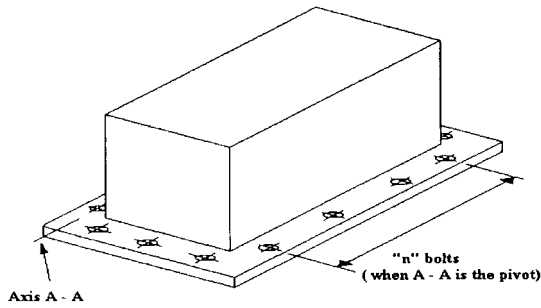

FIG. V.2. General package arrangement.

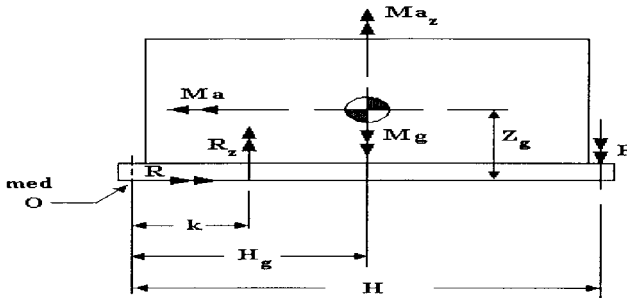

FIG. V.3. Force diagram used in analysis.

present. Several of Refs [V.1–V.27] strongly recommend the chocking of packages as best practice in order to avoid these much higher tie-down strength requirements.

Rectangular package with baseplate flange bolted to the conveyance

V.34. Figure V.2 shows the general arrangement of the rectangular package with a baseplate flange bolted to the conveyance, and the force diagram used in the analysis is shown in Fig. V.3, whilst the symbols used in this analysis are listed in Table V.3. It is assumed that:

- (i) the bolts along the sides parallel with the principal force do not contribute, and that the tipping force is resisted only by the line of bolts along the flange at the far end from O;
- (ii) the flange is undeformable.

TABLE V.3. SYMBOLS USED IN CALCULATION OF A RECTANGULAR PACKAGE WITH BASEPLATE FLANGE BOLTED TO THE CONVEYANCE

a	Acceleration along a horizontal plane (m/s ²)
a _x	Acceleration along the horizontal longitudinal axis x (m/s ²)
a _y	Acceleration along the horizontal lateral axis y (m/s ²)
g	Gravitational constant (m/s ²)
F	Total force on the bolts along the side furthest from O (N)
H	Package length (m)
a _z	Acceleration along the vertical axis z (m/s ²)
H _g	Distance from pivot edge to centre of gravity (m)
k	Distance from pivot edge to point of action of R _z (m)
M	Mass of package (kg)
n	Number of bolts along the side furthest from O
R	Horizontal reaction (N)
R _z	Vertical reaction between package and conveyance (N)
T	Maximum tensile load in each bolt (N)
Z _g	Vertical distance, base to centre of gravity (m)

Resolving the forces vertically,

$$Ma_z + R_z = Mg + F$$

Resolving the forces horizontally,

$$Ma = R$$

Taking moments about O results in

$$R_z k + Ma_z H_g + Ma Z_g = Mg H_g + FH$$

At breakaway, k tends to zero, and the equation reduces to

$$Ma_z H_g + Ma Z_g = Mg H_g + FH$$

Collecting up terms and rearranging gives

$$F = [M\{H_g(a_z - g) + Z_g a\}]/H$$

Hence, the maximum load in each bolt along the side furthest from O, the pivot edge A – A, is:

$$T = F/n \text{ or } T = [M\{H_g(a_z - g) + Z_g a\}]/H_n$$

V.35. The horizontal force on the plane of the base is R. As the packaging is effectively fully chocked by bolting, the sliding forces to be withstood by the bolts on adjacent sides are Ma_x and Ma_y , respectively. For the bolts to be designed to resist R, they must be of the 'shear bolt' type.

DEFINITIONS OF TERMS USED IN APPENDIX V

V.36. For the purposes of the guidance notes in this appendix, the following definitions apply:

Attachment point — A fitting on the package to which a tie-down member or other retention device is secured.

Anchor point — A fitting on the conveyance to which a tie-down member or other retention device is secured.

Chock — A fitting secured to the conveyance for the purpose of absorbing horizontal forces derived from the package.

Dunnage — Loose material used to protect cargo in a ship's hold, or padding in a shipping container.

Retention — The use of dunnage, braces, blocks, tie-downs, nets, flanges, stillages, etc., to prevent package movement within or on a conveyance during transport.

Stillage — A framework fitted to a conveyance for carrying unsecured packages. (Note: A recess or a well is a variation of the stillage concept where it is manufactured into the conveyance.)

Stowage — The locating within or on a conveyance of a radioactive material package relative to other cargo (both radioactive and non-radioactive).

Tie-down member — The connecting component (e.g. wire rope, chain, tie-rod) between the attachment and anchor points.

Tie-down system — The assembly of an attachment point, an anchor point and a tie-down member.

REFERENCES TO APPENDIX V

- [V.1] INTERNATIONAL ORGANIZATION FOR STANDARDIZATION, Packaging of Uranium Hexafluoride (UF₆) for Transport, Rep. ISO 7195:1993(E), ISO, Geneva (1993).
- [V.2] CHEVALIER, G., et. al., “L’arrimage de colis de matières radioactives en conditions accidentelles”, Packaging and Transportation of Radioactive Materials, PATRAM 86 (Proc. Symp. Davos, 1986), IAEA, Vienna (1986).
- [V.3] UNITED KINGDOM ATOMIC ENERGY AUTHORITY, Securing Radioactive Materials Packages to Conveyances, Rep. AECF 1006, UKAEA, Risley (1986).
- [V.4] UNITED STATES DEPARTMENT OF ENERGY, Fuel Shipping Containers Tie-Down for Truck Transport, RTD Standard F8-11T, USDOE, Washington, DC (1975).
- [V.5] OAK RIDGE NATIONAL LABORATORY, Cask Tiedown Design Manual, Analysis of Shipping Casks, Vol. 7.J.T1, Rev. ORNL TM 1312, Oak Ridge National Laboratory, Oak Ridge, TN (1969).
- [V.6] AMERICAN NATIONAL STANDARDS INSTITUTE, American National Standard for Highway Route Controlled Quantities of Radioactive Materials — Domestic Barge Transport, ANSI N14.24-1985, ANSI, New York (1993).
- [V.7] UNITED STATES OFFICE OF THE FEDERAL REGISTER, Title 10, US Code of Federal Regulations, Part 71.45, U.S. Government Printing Office, Washington, DC (1995).
- [V.8] UNION INTERNATIONALE DES CHEMINS DE FER, Agreement Governing the Exchange and Use of Waggon between Railway Undertakings (RIV 1982), Appendix II, Vol. 1 — Loading Guidelines, UIC, Paris (1982).
- [V.9] INTERNATIONAL MARITIME ORGANIZATION, International Code for the Safe Carriage of Irradiated Nuclear Fuel, Plutonium and High Level Radioactive Wastes in Flasks on Board Ships (INF code), International Maritime Dangerous Goods Code, Supplement 1994, IMO, London (1994).
- [V.10] INTERNATIONAL ORGANIZATION FOR STANDARDIZATION, Series 1 Containers — Specification and Testing — Part 3: Tank Containers for Liquids, Gases, and Pressurized Dry Bulk, ISO 1496-3, 4th ed., ISO, Geneva (1995).
- [V.11] VEREIN DEUTSCHER INGENIEURE, Ladungssicherung auf Straßenfahrzeugen; Zurrkräfte, VDI 2702, Beuth Verlag, Berlin (1990).
- [V.12] UNITED STATES OFFICE OF THE FEDERAL REGISTER, Title 49, US Code of Federal Regulations, Part 393.100-102, U.S. Government Printing Office, Washington, DC (1994).
- [V.13] UK DEPARTMENT OF TRANSPORT, Guide to Applications for Competent Authority Approval, DTp/RMTD/0001/Issue 1, HMSO, London (1992).
- [V.14] ANDERSON, G.P., McCARTHY, J.C., Prediction of the Acceleration of RAM Packagings during Rail Wagon Collisions, AEA-ESD-0367, AEA Technology, UK (1995).
- [V.15] SHAPPERT, L.B., RATLEDGE, J.E., MOORE, R.S., DORSEY, E.A., “Computed calculation of wire rope tiedown designs for radioactive material packages”,

- Packaging and Transportation of Radioactive Materials, PATRAM 95 (Proc. Symp. Las Vegas, 1995), USDOE, Washington, DC (1995).
- [V.16] GWINN, K.W., GLASS, R.E., EDWARDS, K.R., Over-the-Road Tests of Nuclear Materials Package Response to Normal Environments, Rep. SAND 91-0079, Sandia National Laboratories, Albuquerque, NM (1991).
- [V.17] DIXON, P., “Tie down systems — Proofs of design calculations”, Packaging and Transportation of Radioactive Materials, TCSP(93)P1072, United Kingdom Transport Container Standardisation Committee (1994).
- [V.18] JOHNSON, R., Packaging tie-down design — Comments and recommendations on Safety Series 37”, Packaging and Transportation of Radioactive Materials, TCSP(95), United Kingdom Transport Container Standardisation Committee (1995).
- [V.19] CORY, A.R., Flask tie-down design and experience of monitoring forces, Int. J. Radioact. Mater. Transp. 2 1–3 (1991) 15–22.
- [V.20] GYENES, L., JACKLIN, D.J., Monitoring the Accelerations of Restrained Packages during Transit by Road and Sea, Rep. PR/ENV/067/94, TRL on behalf of AEA Technology, UK (1994).
- [V.21] BRITISH RAILWAYS BOARD, Requirements and Recommendations for the Design of Wagons Running on BR Lines, MT235 Rev. 4, British Railways Board, London (1989).
- [V.22] UNITED KINGDOM DEPARTMENT OF TRANSPORT, Safety of Loads on Vehicles, HMSO, London (1984).
- [V.23] DIXON, P., “Package tie-downs — A report on a programme of tests and suggestions for changes to design criteria”, Packaging and Transportation of Radioactive Materials, TCSC(96)P99, United Kingdom Transport Container Standardisation Committee (1996).
- [V.24] GILLES, P., et al., Stowing of Packages Containing Radioactive Materials during their Road Transportation with Trucks for Loads up to 38 Tons, Rep. TNB 8601-02, Transnubel SA, Brussels (1985).
- [V.25] DRAULANS, J., et al., Stowing of Packages Containing Radioactive Materials on Conveyances, N/Ref:23.906/85D-JoD/IP, Transnubel SA, Brussels (1985).
- [V.26] KERNTECHNISCHER AUSSCHUSS, Load Attaching Points on Loads in Nuclear Power Plants, Safety Standard KTA 3905, KTA Geschäftsstelle, Bundesamt für Strahlenschutz, Salzgitter (1994).
- [V.27] INTERNATIONAL ORGANIZATION FOR STANDARDIZATION, Freight Containers, Part 2: Specification and Testing of Series 1 Freight Containers, Section 2.1, General Cargo Containers for General Purposes, BS 3951:Part2:Section 2.1:1991/ISO 1496-1: British Standards, ISO, Geneva (1991).

Appendix VI

GUIDELINES FOR SAFE DESIGN OF SHIPPING PACKAGES AGAINST BRITTLE FRACTURE

INTRODUCTION

VI.1. This appendix is based on a text that was published as Chapter 2 of IAEA-TECDOC-717 [VI.1] that was revised in a series of subsequent Consultant Service Meetings. This publication contains further information on the assessment of fracture resistance based on design evaluation using fracture mechanics.

VI.2. Packages for the transport of radioactive materials have to satisfy the IAEA Regulations agreed by all participating countries. The packages have to meet stringent requirements to limit external radiation, to ensure containment of the radioactive material and to prevent nuclear criticality. Compliance with these requirements must be maintained under severe accident conditions. Thus, in the design of such packages, consideration has to be given to the prevention of all modes of failure of the package that could result in the violation of these requirements. It should be noted that in applying this guidance, the requirements of para. 701(d) of the Regulations are always applicable (i.e. the calculation procedures and parameters must be reliable or conservative).

VI.3. This appendix provides guidance for the evaluation of designs to prevent one such potential mode of failure, namely brittle fracture of structural components in radioactive materials transport packages. Three methods are discussed:

- (1) Evaluation and use of materials which remain ductile and tough throughout the required service temperature range, including down to -40°C ;
- (2) Evaluation of ferritic steels using nil-ductility transition temperature measurements correlated to fracture resistance;
- (3) Assessment of fracture resistance based on a design evaluation using fracture mechanics.

VI.4. The first method is included to cover the approach which seeks to ensure that, whatever the loading conditions required to cause failure, such a failure will always involve extensive plasticity and/or ductile tearing, and unstable brittle fracture will not occur in any circumstances. The second is addressed to provide consistency with the generally accepted practice for evaluating ferritic steels. The third provides a method for evaluating brittle fracture that is suitable for a wide range of materials. It

must be emphasized that this guidance does not preclude alternative methods that are properly justified by the package designer and accepted by the competent authority.

GENERAL CONSIDERATION OF EVALUATION METHODS

VI.5. Many materials are known to be less ductile at low temperatures or high loading rates than at moderate temperatures and under static loading conditions. For example, the ability of ferritic steels to absorb energy when stressed in tension with crack-like flaws present changes markedly over a narrow temperature range. Fracture toughness for ferritic steel changes markedly over the transition temperature range. Toughness increases rapidly over a relatively narrow range of temperature from a 'lower shelf' or brittle plane strain region with cleavage fracture, through an elastic plastic region, to an 'upper shelf' or region with ductile tearing fracture and plasticity where the fracture toughness is generally high enough to preclude brittle fracture. The temperature at which the toughness starts to rise rapidly with increasing temperature corresponds to the nil ductility transition temperature (NDTT). This type of transition temperature behaviour only occurs in the presence of crack-like flaws which produce a triaxial stress state, and when the materials show an increase in yield strength with decreasing temperature. The same materials often show an increase of yield strength with increasing loading rate, and hence the transition temperature may also be dependent on loading rate. In all of these cases, when the material is effectively in a brittle state, tensile loading of such materials can lead to unstable crack propagation with subsequent brittle fracture, even when the nominal stresses are less than the material yield strength. Small crack-like defects in the material may be sufficient to initiate this unstable growth.

VI.6. Criteria for the prevention of fracture initiation and potentially unstable fracture propagation in ferritic steel components, such as pressure vessels and piping used in the power, petroleum and chemical process industries, are well developed, and have been codified into standard practice by a number of national and international standard writing bodies. These criteria can be classified into two general types:

- (1) Criteria based solely on material testing requirements. These are usually intended to demonstrate that some material property (e.g. impact energy) has been shown by previous experience or by full scale demonstration prototype tests to give satisfactory performance, or may be correlated to fracture toughness to provide adequate margin against brittle fracture.
- (2) Criteria based on a combination of material testing, calculation of applied stresses and workmanship/inspection standards. These are intended to demonstrate that a sufficient margin exists between the calculated design state and the measured material response state.

VI.7. Methods 1 and 2 are based on the criteria of the first approach above, whilst Method 3 follows the basic fracture mechanics approach or the extensions to elastic plastic fracture mechanics described later. It should be noted that whilst linear elastic fracture mechanics can be used provided that small scale yielding limits prevail, if more extensive yielding occurs then elastic plastic fracture mechanics methods should be used. Other evaluation methods are possible. Any approach suggested by the package designer is subject to the approval of the competent authority.

Method 1

VI.8. Brittle fracture can occur suddenly, without warning, and have disastrous consequences for the packaging. Consequently, the Method 1 approach is that packaging should be constructed of materials that are not subject to brittle failure before ductile failure when subjected to the normal and accident conditions specified in the Regulations.

VI.9. An example of the first method is the use of austenitic stainless steels for the flask material. These materials do not have fracture toughness behaviour sensitive to temperature over the range of interest in package designs and generally have good ductility and toughness performance. It is not always the case that cast austenitic steels have good properties, however, and some form of mechanical testing to confirm ductile behaviour and high fracture toughness may be required.

VI.10. Method 1 also has the benefit of not having to rely on limiting stress levels, flaw sizes and fracture toughness for brittle fracture resistance although normal design procedures have to be applied for ductile or other modes of failure.

Method 2

VI.11. The basis for determining the NDTT is the highest temperature at which brittle fracture does not run in the parent material from a brittle weld bead in the standard drop weight test [VI.2]. This can be thought of as the bottom of the transition temperature curve either for propagation/crack arrest or for dynamic initiation from small initial cracks.

VI.12. Examples of the use of the NDTT approach of Method 2 include the British Standards Institution's BS 5500 [VI.3], the ASME Sections III [VI.4] and VIII [VI.5] and the RCC-M Appendix ZG of the French Nuclear Construction Code [VI.6]. These methods address, for example, ferritic steels, for which there are substantial databases relating impact energy (Charpy testing) to fracture toughness. In such cases, the Charpy impact energy can be used as an indirect indicator of material

toughness. This approach may be used for a variety of high quality carbon and carbon–manganese ferritic steels. The basic acceptance criterion for BS 5500 and the two ASME Code documents is the requirement of a minimum impact energy (or lateral expansion) from a Charpy V-notch test at a prescribed temperature, although the underlying justification is based on NDTT approaches.

VI.13. Another example of the second method is the US Nuclear Regulatory Commission (USNRC) regulatory guides, Fracture Toughness Criteria for Ferritic Steel Shipping Cask Containment Vessels with a Wall Thickness Greater Than Four Inches (0.1 m), Reg. Guide 7.12 [VI.7], and Fracture Toughness Criteria of Base Material for Ferritic Steel Shipping Cask Containment Vessels with a Maximum Wall Thickness of Four Inches (0.1 m), Reg. Guide 7.11 [VI.8]. These criteria prescribe levels of NDTT which must be achieved for ferritic steels, based on section thickness and temperature. They require a minimum temperature difference between the NDTT of the material and the lowest temperature to be considered for accident conditions (taken as -29°C), as a function of section thickness. This temperature difference is based on correlations between NDTT and fracture toughness. While these regulatory guides specifically address ferritic steels, the same approach could be considered for other materials showing transition temperature behaviour and for which a correlation between NDTT and fracture resistance can be demonstrated. The standardized test procedure ASTM A208 is only applicable for ferritic steels. There are no standardized test methods for measuring the NDTT of other materials. There is, however, the possibility of using the dynamic tear test (DT) to obtain the NDTT or at least an indication of tearing resistance for other materials [VI.9]. This will give more severe (conservative) values than those derived from Charpy tests.

VI.14. It should be noted that the USNRC gives consideration to different safety margins for different types of package and contents and also takes into account crack arrest behaviour of materials [VI.7, VI.8]. This is achieved by specifying a maximum allowable NDTT based on technical reports by Lawrence Livermore National Laboratories [VI.10, VI.11] and the following equation:

$$\beta = \frac{1}{B} \left(\frac{K_{ID}}{\sigma_{yd}} \right)^2 \quad (\text{VI.1})$$

where

σ_{yd} is the dynamic yield stress,
 K_{ID} is the critical dynamic fracture toughness, and
 B is the section thickness,
 all in consistent units.

VI.15. For spent fuel, high level waste and plutonium packages, the USNRC looks for sufficient fracture toughness to prevent the extension of a through-thickness crack at dynamic yield stress level, which amounts to a crack arrest philosophy, requiring β not less than 1.0. This is equivalent to requiring a nominal plastic zone size such that plane strain conditions would not be expected to be maintained so that the fracture toughness should be towards the upper shelf region and ductile. For other Type B packages, the required value of β should be not less than 0.6. This is equivalent to requiring that the fracture toughness should be off the bottom shelf and in the transition region, with elastic plastic failure expected to dominate. For packages that contain only LSA materials or less than 30 A₁ or 30 A₂, the USNRC is prepared to consider use of linear elastic fracture mechanics approaches to prevent fracture initiation. This can be achieved by requiring β to be not less than 0.4. For these cases, for thicknesses less than 4 in. (0.1 m), the use of fine grained normalized steels without further analysis or testing may be considered. For all these approaches the required fracture toughness can be specified by use of maximum NDT temperature. These approaches also have the benefit of not having to rely on limiting stress levels and flaw sizes. However, again, normal design procedures have to be applied for ductile or other modes of failure.

Method 3

VI.16. For the transport of nuclear materials, the first and second methods do not take advantage of the designer's ability to limit stresses through the provision of impact limiting devices and non-destructive examination (NDE) sufficient to detect and size prescribed flaws. Furthermore, the correlation of impact energy to fracture toughness may not be applicable to a broad range of materials, thereby restricting the designer's use of alternative containment boundary materials.

VI.17. Numerous examples of the third method that are valid for nuclear power plant components can be identified. Such examples, although not directly applicable to the evaluation of transport package design, may be instructive in terms of their use of fracture mechanics principles. These examples include Appendix G of ASME Section III [VI.12]; RCC-MR of the French Nuclear Construction Code [VI.13]; MITI Notification 501 from Japan [VI.14]; the German nuclear design code KTA 3201.2 [VI.15]; the British Standards Institution document PD 6493:1991 [VI.16]; and the Confederation of Independent States (CIS) document [VI.17]. These examples allow the designer the latitude of material selection together with the ability to determine stresses and NDE requirements such that fracture initiation and brittle fracture are precluded. The fundamental approach for linear elastic fracture mechanics is applied in all of these cases, although differences arise in the application of safety factors. These examples are mainly concerned with slowly applied loads, which may fluctuate. For application of these principles for loads encountered in drop

or penetration tests, account must be taken both of the magnitude of the resulting stresses and of the material response to the rate of loading.

CONSIDERATIONS FOR FRACTURE MECHANICS

VI.18. The mechanical property that characterizes a material's resistance to crack initiation from pre-existing crack-like defects is its initiation fracture toughness. Measurements of this property, as a function of temperature and loading rate, trace out the transition from brittle to ductile behaviour for those materials which show transition temperature behaviour. Depending on the localized state of stress around the defect and the extent of plasticity, the fracture toughness is measured in terms of the critical level of the stress intensity factor (K_I), if the stress-strain conditions are linear-elastic; or, if the stress-strain conditions are elastic-plastic, the toughness may be represented by the critical level of the energy line contour integral J_I or by the critical level of the crack tip opening displacement (CTOD) δ . According to fundamental fracture mechanics theory, the level of the applied crack tip driving force, represented by stress intensity factor K_I , contour integral J_I or CTOD δ_I , must be less than the critical value for the material's fracture toughness in the same form, $K_{I(\text{mat})}$, $J_{I(\text{mat})}$ or $\delta_{I(\text{mat})}$ to preclude fracture initiation and subsequent brittle fracture. Standard testing methods for critical values of K_I are given in ASTM E399 [VI.18] and JSME S001 [VI.19]; for critical values of J_I in ASTM E813 [VI.20] and JSME S001 [VI.19]; and for critical values of CTOD in BS 7448-2 [VI.21], ASTM E1290 [VI.22] and JWES 2805 [VI.23]. Discussions are in progress to produce a single set of recommendations to cover the various different fracture toughness parameters [VI.24]. Hence the particular value of $K_{I(\text{mat})}$, $J_{I(\text{mat})}$ or $\delta_{I(\text{mat})}$ necessary to avoid fracture initiation depends on the loading and environmental combinations of interest. For plane strain conditions, appropriate for the high thicknesses often necessary for many Type B packages, the critical fracture toughness for static loading shows a minimum value which is termed K_{Ic} , J_{Ic} or δ_{Ic} . Further, the fracture toughness under increased loading rate or impact conditions, which is termed K_{Id} for dynamic loading, may be significantly lower for some materials than the corresponding static value at the same temperature, K_{Ic} . If the initial depth of the defect, in combination with the applied loading, results in an applied stress intensity factor that equals the material toughness, crack initiation will occur and the depth of the defect is referred to as the critical depth. Under these conditions continued propagation may occur, leading to instability and failure.

VI.19. For some materials, results of fracture toughness tests that are valid in accordance with ASTM E399 [VI.18] cannot be obtained in the standard tests because of excessive plasticity. Furthermore, some materials may not show unstable fracture

propagation when initiation occurs, but further crack extension requires an increase in the crack driving force, i.e. in the early stages an increase in load is required to cause further crack growth. Both of these processes, i.e. plasticity and stable ductile tearing, absorb energy and are clearly desirable attributes for materials required to meet the demanding design requirements for transport flasks. It should be noted that the geometric and metallurgical effects of large section thicknesses often used in package designs make it difficult to be certain of ductile tearing response in service as compared with standard test geometries.

VI.20. The recommended approach for fracture mechanics evaluation of transport package designs is based on the 'prevention of fracture initiation' and hence of unstable crack propagation (growth) in the presence of crack-like defects. The principles of linear-elastic fracture mechanics may sometimes be sufficient. Under some conditions, and as justified by the package designer and accepted by the competent authority, the principles of elastic-plastic fracture mechanics may be appropriate. In such cases, the prevention of crack initiation remains the governing criterion and no reliance in design should be placed on any predicted ductile tearing resistance. Guidance is provided in the following paragraphs for design against fracture initiation in packages subjected to the mechanical tests prescribed in paras 722, 725 and 727 of the Regulations.

VI.21. The implication of adopting an approach based on fracture mechanics is that quantitative analysis should be carried out. The analysis should cover the interaction between postulated flaws in the package, stress levels which may occur, and the properties of the materials, particularly fracture toughness and yield strength. Thus consideration should be given to the possible presence of flaws at the manufacturing stage, and the design method has to postulate maximum flaw sizes that could credibly occur and remain after any inspection and repair programme. This in turn means that the type of inspection methods and their capability to detect and size such flaws at critical geometric locations have also to be considered. In this appendix this is the basis of the reference flaw concept. It is likely that a combination of non-destructive testing methods will be necessary. The appropriate combination to be specified by the designer should include locations to be inspected by each method and the acceptance levels for any flaws found. The inspectability of the geometry in relation to the size and location of flaws that might be missed is an important element of any design approach making use of fracture mechanics principles. These aspects are discussed further later in this appendix. Furthermore, it must be possible to determine the stress levels that would occur in different parts of the package under the various design accident conditions and to have some estimate of the uncertainties in such determinations. Finally, there must be knowledge of the fracture toughness of the material used for the package over the full temperature

range of operating conditions, based on either test results, lower bound estimates or reference curves, and including the effects of increased rates of loading that will occur under impact accidents.

VI.22. The fundamental linear-elastic fracture mechanics equation which describes structural behaviour in terms of the crack tip driving force as a function of applied stress and flaw depth is as follows:

$$K_I = Y\sigma\sqrt{\pi a} \quad (\text{VI.2})$$

where

K_I is the applied stress intensity factor ($\text{MPa}\sqrt{\text{m}}$),

Y is the constant based on size, orientation and geometry of flaw and structure,

σ is the applied nominal stress (MPa), and

a is the flaw depth (m).

VI.23. Further, to preclude brittle fracture, the applied stress intensity factor should satisfy the relationship

$$K_I < K_{I(\text{mat})} \quad (\text{VI.3})$$

where $K_{I(\text{mat})}$ defines the fracture toughness.

VI.24. This must be obtained from tests at the appropriate rate of loading relevant to that which will be experienced by the package, with account taken of the effects of any stress limiters included in the design.

VI.25. For

$$K_I = K_{I(\text{mat})} \quad (\text{VI.4})$$

Eq. (VI.2) can be combined with Eq. (VI.4) to give an expression for the critical flaw depth a_{cr} as follows:

$$a_{\text{cr}} = \frac{1}{\pi} \left(\frac{K_{I(\text{mat})}}{Y\sigma} \right)^2 \quad (\text{VI.5})$$

VI.26. The purpose of the brittle fracture evaluation process is to ensure that the three parameters of this characterization (material fracture toughness, applied stress and flaw size) satisfy Eqs (VI.2) and (VI.3), or corresponding elastic-plastic treatments, thereby precluding fracture initiation.

VI.27. The effect of plasticity and local yielding at the tip of a crack is to increase the crack tip severity above that for the same crack size and stress level under linear–elastic stressing conditions alone. In elastic–plastic fracture mechanics, there are a number of ways of taking into account the interaction between plasticity and crack tip severity. For example, two of these approaches have been codified into various national documents — the applied J-integral [VI.25] and the failure assessment diagram [VI.16, VI.26] — and can be justified for use in packaging evaluations. Acceptance criteria for these elastic–plastic methods are typically more complex than the simple limit provided by Eq. (VI.3). For the case of the applied J-integral method, such criteria should include a limit on the applied J-integral itself at the prescribed definition of initiation. For the failure assessment diagram (FAD) method, the assessment co-ordinates L_r and K_r for plastic collapse and brittle fracture can be calculated for stresses and postulated flaw depths, with a requirement that such assessment points lie inside the FAD surface (see Fig. VI.1). It is important to recognize that when significant yielding occurs, use of linear–elastic fracture mechanics may be non-conservative if the stress intensity factor is estimated only from the stress level and crack size without account taken of yielding. For further details the full treatments of these approaches should be consulted [VI.17, VI.25, VI.26].

VI.28. It should be noted that yielding of components outside the containment boundary which are specifically designed to absorb energy by plastic flow should not be regarded as unacceptable.

SAFETY FACTORS FOR METHOD 3

VI.29. Any safety factors that might be applied to Eq. (VI.3), or to the parameters that make up Eq. (VI.3) and its elastic–plastic extensions, must account for uncertainties in the calculation or measurement of these parameters. These uncertainties might include those associated with the calculation of the state of stress in the package, the examination of the package for defects, and the measurement of material fracture toughness. Thus the overall safety factor required depends on whether the values used for the different input parameters are best estimate (mean) values or upper bounds for loading parameters and postulated defect sizes and lower bounds for fracture toughness. In particular, concern about uncertainty in NDE can be accommodated by appropriate conservatism in the selection of the reference flaw.

VI.30. For the purposes of prevention of fracture initiation in package materials, the safety factors for normal conditions of transport and hypothetical accident conditions should be in general agreement with safety factors that have been developed for

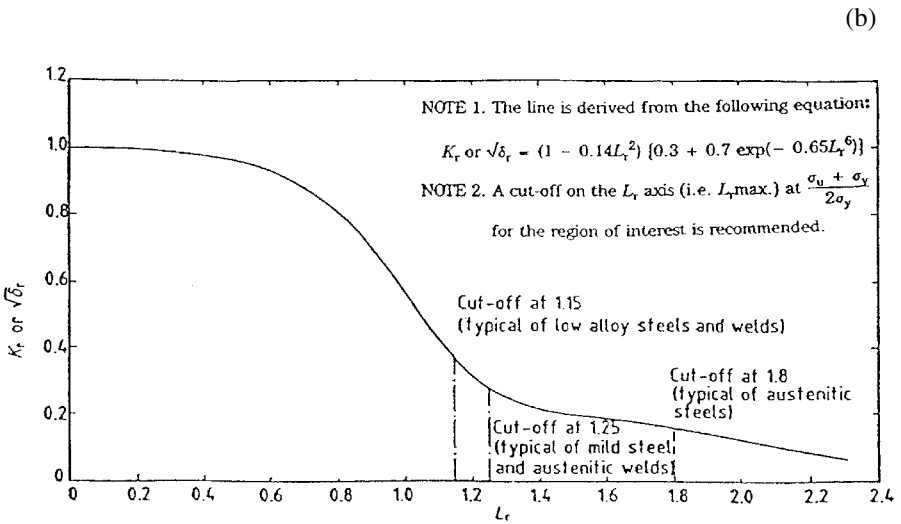
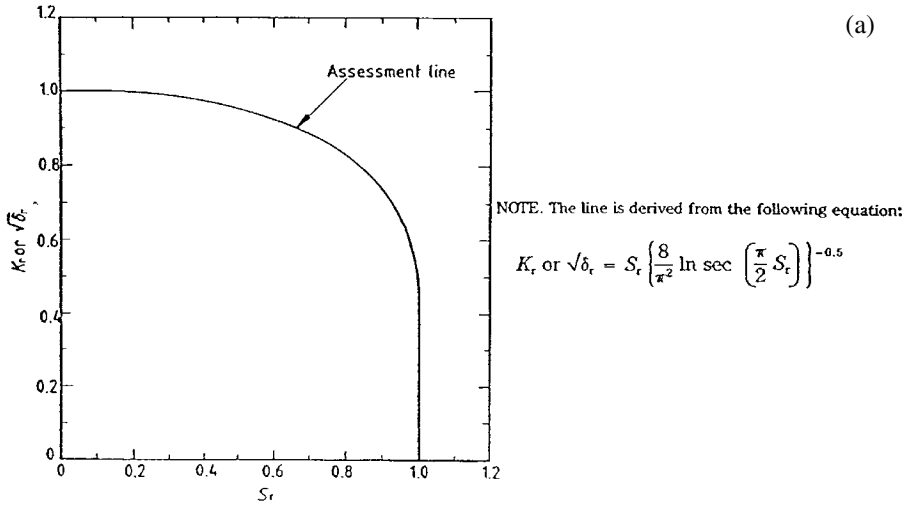

FIG. VI.1. Failure assessment diagrams for elastic-plastic fracture mechanics treatments [VI.16]. (a) Level 2 assessment diagram, (b) Level 3 assessment diagram.

similar loading conditions in the referenced applications of the linear-elastic fracture mechanics approach. For example, for loading conditions that are expected to occur as part of normal operation during service life, the ASME Code Section XI for in-service inspection of nuclear power plant components provides for an overall minimum safety factor of $\sqrt{10}$ (approximately 3) on fracture toughness to be applied to Eq. (VI.3). For unexpected (but design basis) loading conditions, such as the hypothetical accident conditions, the ASME Code Section XI provides for an overall minimum safety factor of $\sqrt{2}$ (approximately 1.4) on fracture toughness to be applied to Eq. (VI.3). It should be noted that such minimum safety factors to Eq. (VI.3) should use upper bounds for loading parameters and postulated defect sizes and lower bounds for fracture toughness, by using statistical assessments if appropriate. The factors of safety should be selected and justified by the package designer, with acceptance by the competent authority, taking into account confidence in validation of methods used for stress analysis (e.g. finite element analysis codes), scatter in material properties and uncertainties in flaw detection and sizing by NDE.

EVALUATION PROCEDURE FOR METHOD 3

VI.31. The general steps to be followed in order to apply the recommended approach should be: (1) postulation of a reference, or design basis, flaw at the most critical location in the packaging and in the most critical orientation; (2) calculation of the stresses due to the mechanical tests described in paras 722, 725 and 727 of the Regulations, and ensuring that any required load combinations are considered; (3) calculation of the applied stress intensity factor at the tip of the design basis flaw; (4) determination or lower bound estimate of the fracture toughness of the material for the loading rates to which the package may be subjected; (5) calculation of the ratio of applied net section stress to yield stress under the relevant loading conditions; and (6) satisfaction of any margin of safety between the applied net stress intensity factor and the accepted material fracture toughness value, and between the applied stress and yield stress. This will ensure that the flaw will not initiate or grow as a result of mechanical tests specified by the Regulations, and therefore will not lead to unstable crack propagation and/or brittle fracture. The net stress is the evaluated stress that takes into account the reduced section due to the presence of the crack.

VI.32. A variation on this sequence is for the mechanical tests to be used to demonstrate the resistance to brittle fracture directly. In this case, the test measurements may be used for either, or both, of two purposes — to provide inference of the stress field for calculations of applied stress intensity factors, or to provide direct confirmation of the recommended margin against fracture initiation.

For the second of these, a crack is placed in the location of the prototype test packaging that is most vulnerable to flaw initiation and growth from the mechanical test loads under consideration at a minimum temperature of -40°C . The reference flaw shape should be semi-elliptical, with an aspect ratio (length to depth) of 6:1 or greater. The tip of this artificial flaw should be as crack-like as possible, with a reference flaw acuity that is justified by the package designer and accepted by the competent authority. An acuity of the radius at the extreme tip of the crack of not greater than 0.1 mm has been suggested for ductile iron [VI.27]. The depth of this flaw is determined by using stresses as previously calculated or inferred from strain measurements, and an appropriate factor of safety should also be considered when computing the artificial flaw depth.

VI.33. Recommendations for each of these procedural steps are provided in the following paragraphs.

Flaw considerations

VI.34. Three different flaw sizes are referred to in this appendix. The ‘reference flaw size’ is a postulated flaw size used for analysis purposes. The ‘rejection flaw size’ is a flaw size which, if discovered during pre-service inspection, would fail to meet quality assurance requirements. The ‘critical flaw size’ is that size which would potentially be unstable under design basis loading conditions.

VI.35. With respect to either demonstration by analysis or demonstration by test, the reference flaw should be placed at the surface of the packaging containment wall at the location of the highest applied stress. The possibility of fatigue cracks developing in service should be considered where the package is subjected to cyclic or fluctuating loads. Where the location of the highest applied stress is uncertain, multiple demonstrations may be required. The orientation of the reference flaw should be such that the highest component of surface stress, as determined from calculations or experimental measurements, is normal to the plane of the flaw. This consideration should take account of the presence of any stress concentration regions. The depth of the reference flaw should be such that its relationship to volumetric examination sensitivity, detection uncertainty, rejection flaw size and critical flaw size is justified. The reference flaw depth should be such that, in association with the demonstrated volumetric and surface examination sensitivity, the non-detection probability is ensured to be sufficiently small, as justified by the package designer. A limiting small depth may be chosen at the size where the probability of non-detection can be demonstrated to be statistically insignificant, with due allowance for uncertainties in the testing method.

VI.36. The reference flaw of 6:1 aspect ratio should have an area, normal to the direction of maximum stress, greater than typical pre-service inspection indications that might be cause of rejection or repair of a fabricated packaging containment wall. However, since the reference flaw is a crack-like surface defect, rather than a more typical real defect (e.g. subsurface porosity cloud or slag inclusion), the selection of this flaw size is extremely conservative relative to workmanship standards.

Quality assurance and non-destructive examination considerations

VI.37. For the satisfactory performance of any transport package, it should be designed and manufactured to satisfactory standards, with suitable materials, and free of gross flaws, irrespective of whether a design approach based on fracture mechanics has been used or not. The implication is that the design and manufacturing stages should be subject to quality assurance principles, and the materials should be subject to quality control to ensure that they are within specification requirements. For metallic packages, samples should be taken to check that chemical analysis, heat treatment and microstructure are satisfactory and no inherent flaws are present. Metallic packages should be subject to non-destructive testing with a combination of surface crack detection and volumetric testing. Surface crack detection should be done by appropriate means such as magnetic crack detection, dye penetrant or eddy current testing in accordance with standard procedures.

VI.38. Volumetric testing should normally be by radiographic or ultrasonic methods, again in accordance with standard procedures. The design of the package should be suitable for non-destructive testing. Where an approach based on fracture mechanics is used with a reference flaw concept, the designer of the package must demonstrate that the specified NDE methods are able to detect any such flaw, and these NDE methods must be carried out in practice.

VI.39. Consideration should be given by the designer to the possibility of flaws developing or growing and to possible material degradation in service. Requirements for repeat or periodic NDE should be specified by the designer and approved by the competent authority.

Fracture toughness considerations

VI.40. The calculated applied stress intensity factor should be shown to be less than the material fracture toughness value in Eq. (VI.3), with appropriate allowance for plasticity effects and factors of safety. The method for determining the material fracture toughness should be selected from three options, all of which are illustrated

in Fig. VI.2. Each of these options includes the generalization of a statistically significant database of material fracture toughness values obtained on product forms that are representative of material suppliers and package applications. The first two options should include material fracture toughness values that are representative of the strain rate, temperature and constraint conditions (e.g. thickness) of the actual package application. These same considerations apply to material fracture toughness measurements used to support an elastic-plastic fracture evaluation.

VI.41. Option 1 should be based on the determination of a minimum value of fracture toughness at a temperature of -40°C for a specific material. The minimum value is shown in Fig. VI.2 as representing a statistically significant data set, for a limited number of samples from a limited number of material suppliers, obtained at appropriate loading rate and geometric constraint conditions. The samples should be representative of product forms appropriate for the particular package application.

VI.42. Option 2 should be based on the determination of a lower bound or near lower bound value of the material fracture toughness, $K_{I(\text{mat})} = K_{Ib}$, as shown in Fig. VI.2. This option would encompass, as a limiting case, the reference material fracture toughness determination for ferritic steels that is prescribed, for example, in

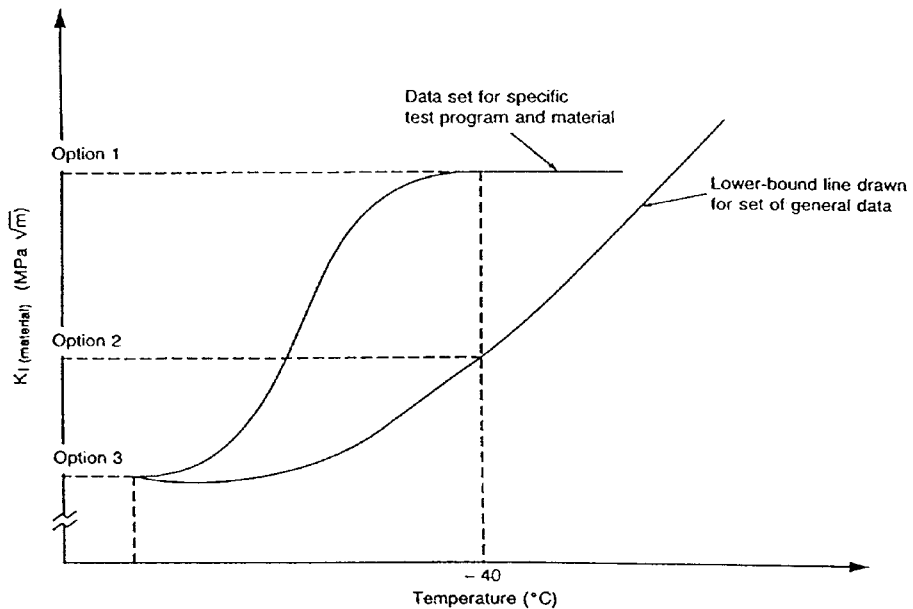

FIG. VI.2. Relative values of $K_{I(\text{mat})}$ measurements based on the selection of options 1, 2 or 3.

the ASME Code Section III, Appendix G [VI.4]. The lower bound or near lower bound value can be based on a composite of data for static, dynamic and crack arrest fracture toughness. An advantage of this option is the potential for reducing the testing programme for materials that can be referenced to the lower bound or near lower bound curve. A relatively small, but suitable, number of data points may be sufficient to demonstrate the applicability of the curve to specific heats, grades or types of material.

VI.43. Option 3 should be based either on the minimum value of a statistically significant fracture toughness data set satisfying the static loading rate and crack tip constraint requirements of ASTM E399 [VI.18] or on elastic–plastic methods of measuring fracture toughness [VI.3, VI.4]. The test temperature for LEFM tests to ASTM E399 should be at least as low as -40°C , but may have to be even lower to satisfy the ASTM E399 conditions, as shown in Fig. VI.2. Fracture toughness tests using elastic–plastic methods should be carried out at the minimum design temperature. The conservatism of this option, particularly if tests are carried out at temperatures lower than -40°C , may be such that, if justified by the package designer and accepted by the competent authority, a reduced factor of safety could be used.

Stress consideration

VI.44. With respect to either demonstration by test or analysis, the calculation of the applied stress intensity factor at the tip of the reference flaw should be based on maximum tensile stresses in the fracture critical components that are justified by the package designer and accepted by the competent authority. The fracture critical components are defined as those components whose failure by fracture could lead to penetration or rupture of the containment system. The stresses may be determined by calculations for an unflawed package. Methods commonly used include direct stress calculations by specialist finite element codes for dynamic analysis or indirect stress calculation from test results. With finite element analysis, the approach to impact loading either may be to attempt to model inertia effects or may be quasi-static, provided that the response of impact limiters and the packaging body can be decoupled. The use of finite element computer codes should be limited to those capable of performing impact analysis and to designers who have demonstrated their qualification to the satisfaction of the competent authority. The computer model must be adjusted to give accurate results in the critical areas for each impact point and attitude examined. When the stress field is inferred from surface strain measurements on either a scale model or full scale package performance test, the inferred stress field should also be justified. Account should be taken of possible errors in measured strains due to either placement errors or gauge length effects when strain gauges are used on local stress concentration regions. The applied stress intensity factor may be

calculated directly from stress analysis or calculated conservatively from handbook formulas that account for flaw shape and other geometric and material factors.

VI.45. Since the calculated stress fields may be dependent on impact limiter performance, mass distributions and structural characteristics of the package itself, the justification of the stresses will in turn depend on the justification of the analytical models. Where reliance is placed on impact limiters to ensure that design stress levels used in conjunction with reference flaws and assumed minimum fracture toughness are not exceeded, validation of the analysis should be provided by the designer to the competent authority, including justification of safety factors to allow for uncertainties. Experience of using dynamic finite element analyses has shown that sufficiently reliable or conservative estimates of peak stress can be obtained provided that (i) the computer code is capable of analysing impact events; (ii) reliable or conservative property data are used; (iii) the model is either accurate or has conservative simplifications; and (iv) the analysis is carried out by qualified personnel. The justification of stress fields inferred from performance tests will depend on the justification of test instrumentation characteristics, locations and data interpretation. Evaluation of either calculated or inferred stress fields may also require an understanding of relevant dynamic material and structural characteristics.

VI.46. Additional guidance in the application of Method 3 can be found elsewhere [VI.28–VI.30].

REFERENCES TO APPENDIX VI

- [VI.1] INTERNATIONAL ATOMIC ENERGY AGENCY, Guidelines for the Safe Design of Shipping Packages against Brittle Fracture, IAEA-TECDOC-717, IAEA, Vienna (1993).
- [VI.2] AMERICAN SOCIETY FOR TESTING AND MATERIALS, Annual Book of ASTM Standards: Standard Test Method for Drop Weight Test to Determine Nil Ductility Transition Temperature of Ferritic Steels, Vol. 03.01, ASTM E208-87a, ASTM, Philadelphia, PA (1987).
- [VI.3] BRITISH STANDARDS INSTITUTION, Specification for Unfired Fusion Welded Pressure Vessels, BS 5500, BSI, London (1991).
- [VI.4] AMERICAN SOCIETY OF MECHANICAL ENGINEERS, Boiler and Pressure Vessel Code, Section III, Division 1, Rules for the Construction of Nuclear Power Plant Components, ASME, New York (1992).
- [VI.5] AMERICAN SOCIETY OF MECHANICAL ENGINEERS, Boiler and Pressure Vessel Code, Section VIII, Division 1, Rules for the Construction of Pressure Vessels, ASME, New York (1992).

- [VI.6] ASSOCIATION FRANÇAISE POUR LES RÈGLES DE CONCEPTION ET DE CONSTRUCTION DES MATÉRIELS DES CHAUDIÈRES ELECTRO-NUCLÉAIRES (AFCEN), French Nuclear Construction Code; RCCM: Design and Construction Rules For Mechanical Components of PWR Nuclear Facilities, Subsection Z, Appendix ZG, Fast Fracture Resistance, Framatome, Paris (1985).
- [VI.7] UNITED STATES NUCLEAR REGULATORY COMMISSION, Fracture Toughness Criteria for Ferritic Steel Shipping Cask Containment Vessels with a Wall Thickness Greater than Four Inches (0.1 m), Regulatory Guide 7.12, USNRC, Washington, DC (1991).
- [VI.8] UNITED STATES NUCLEAR REGULATORY COMMISSION, Fracture Toughness Criteria of Base Material for Ferritic Steel Shipping Cask Containment Vessels with a Maximum Wall Thickness of Four Inches (0.1 m), Regulatory Guide 7.11, USNRC, Washington, DC (1991).
- [VI.9] ROLFE, S.T., BARSOM, J.M., Fracture and fatigue control in structures, Prentice-Hall, Englewood Cliffs, NJ (1977).
- [VI.10] HOLMAN, W.R., LANGLAND, R.T., Recommendations for Protecting Against Failure by Brittle Fracture in Ferritic Steel Shipping Containers up to Four Inches Thick, NUREG/CR-1815, US Nuclear Regulatory Commission, Washington, DC (1981).
- [VI.11] SCHWARTZ, M.W., Recommendations for Protecting Against Failure by Brittle Fracture in Ferritic Steel Shipping Containers Greater than Four Inches Thick, NUREG/CR-3826, US Nuclear Regulatory Commission, Washington, DC (1984).
- [VI.12] AMERICAN SOCIETY OF MECHANICAL ENGINEERS, Boiler and Pressure Vessel Code, Section III, Division 1 — Appendices, Appendix G: Protection Against Nonductile Failure, ASME, New York (1992).
- [VI.13] ASSOCIATION FRANÇAISE POUR LES REGLÈS DE CONCEPTION ET DE CONSTRUCTION DES MATÉRIELS DES CHAUDIÈRES ELECTRO-NUCLÉAIRES (AFCEN), French Nuclear Construction Code, RCC-MR: Design and Construction Rules For Mechanical Components of FBR Nuclear Islands, Framatome, Paris (1985, with addendum 1987).
- [VI.14] MINISTRY FOR INTERNATIONAL TRADE AND INDUSTRY, Technical Criteria for Nuclear Power Structure, Notification No. 501, MITI, Tokyo (1980).
- [VI.15] KERNTECHNISCHER AUSSCHUSS, Sicherheitstechnische Regel des KTA, Komponenten des Primärkreises von Leichtwasserreaktoren, Teil 2: Auslegung, Konstruktion und Berechnung, KTA 3201.2, Fassung 3/84, KTA Geschäftsstelle, Bundesamt für Strahlenschutz, Salzgitter (1985).
- [VI.16] BRITISH STANDARDS INSTITUTION, Guidance on Methods for Assessing the Acceptability of Flaws in Fusion Welded Structures, PD 6493, BSI, London (1991).
- [VI.17] RUSSIAN FEDERATION FOR STANDARDIZATION AND METROLOGY, Determination of Fracture Toughness Characteristics under Static Loading, GOST 25.506-85, GOST, Moscow (1985).
- [VI.18] AMERICAN SOCIETY FOR TESTING AND MATERIALS, Annual Book of ASTM Standards: Standard Test Method for Plane Strain Fracture Toughness of Metallic Materials, Volume 03.01, ASTM E399-83, ASTM, Philadelphia, PA (1983).

- [VI.19] THE JAPAN SOCIETY OF MECHANICAL ENGINEERS, Standard Test Method for CTOD Fracture Toughness Testing, JSME S001, JSME, Tokyo (1981).
- [VI.20] AMERICAN SOCIETY FOR TESTING AND MATERIALS, Standard Test Method for J_{Ic} , A Measure of Fracture Toughness, ASTM E813, Annual Book of ASTM Standards, Vol 03.01, ASTM, Philadelphia, PA (1991).
- [VI.21] BRITISH STANDARDS INSTITUTION, Fracture Mechanics Toughness Tests, Method for Determination of K_{Ic} , Critical CTOD and Critical J Values of Welds in Metallic Materials, BS 7448-2, BSI, London (1997).
- [VI.22] AMERICAN SOCIETY FOR TESTING AND MATERIALS, Standard Test Method for Crack Tip Opening Displacement (CTOD) Fracture Toughness Measurement, ASTM E1290-93, Annual Book of ASTM Standards, ASTM, Philadelphia, PA (1993).
- [VI.23] THE JAPAN WELDING ENGINEERING SOCIETY, Standard Test Method for CTOD Fracture Toughness Testing, JWES 2805, JWES, Tokyo (1980).
- [VI.24] INTERNATIONAL ORGANIZATION FOR STANDARDIZATION, ISO/TC164/SC4 — Discussions on a Unified Method of Test for Quasi-static Fracture Toughness — N128, ISO, Geneva (1994).
- [VI.25] ZAHOOR, A., Ductile Fracture Handbook, Rep. NP 6301-D, EPRI, Palo Alto, CA (1991).
- [VI.26] CENTRAL ELECTRICITY GENERATING BOARD, Assessment of the Integrity of Structures Containing Defects, Rep. R/H/R6-Rev. 3, CEGB, London (1986).
- [VI.27] CENTRAL RESEARCH INSTITUTE OF ELECTRIC POWER INDUSTRY, Research on Quality Assurance of Ductile Cast Iron Casks, EL 87001, CRIEPI, Tokyo (1988).
- [VI.28] DROSTE, B., SORENSON, K. (Eds), Brittle fracture safety assessment, Int. J. Radioact. Mater. Transp. **6** 2–3 (1995) 101–223.
- [VI.29] SHIRAI, K., et al., Integrity of cast iron cask against free drop test — Verification of brittle failure design criterion, Int. J. Radioact. Mater. Transp. **4** 1 (1993) 5–13.
- [VI.30] ARAI, T., et al., Determination of lower bound fracture toughness for heavy section ductile cast iron (DCI) and small specimen tests, ASTM STP No. 1207, ASTM, Philadelphia, PA (1995) 355–368.

Appendix VII

CRITICALITY SAFETY ASSESSMENTS

INTRODUCTION

VII.1. This appendix offers general advice on the demonstration of compliance with the requirements for packages containing fissile material set forth in paras 671 to 682 of the Regulations. Performance and documentation of a thorough criticality safety assessment provides the demonstration of compliance called for in these paragraphs. The documentation of the criticality safety assessment included in a Safety Assessment Report (SAR) is an essential part of the application for approval to the competent authority. This criticality safety assessment should be performed by the application of suitable quality assurance procedures at all stages as prescribed in para. 813.

VII.2. Although criticality safety assessments can sometimes be developed using safe subcritical limits for mass or dimensions (example references for limiting data can be found in the literature [VII.1–VII.6]), computational analyses are more commonly used to provide the bases. Thus, this appendix provides recommendations on the analysis approach that should be considered and the documentation that should be provided for the various aspects of the criticality safety assessment set forth in paras 671–682. The basis for acceptance of the calculated results for establishing subcriticality for regulatory compliance is considered.

PACKAGE DESCRIPTION

VII.3. The criticality section of the SAR for a transportation package should include a description of the packaging and its contents. This description should focus on the package dimensions and material components that can influence reactivity (e.g. fissile material inventory and placement, neutron absorber material and placement, reflector materials) rather than structural information such as bolt placement, trunnions, etc. Engineering drawings and design descriptions should be invoked to specify the details of manufactured components.

VII.4. The SAR should clearly state the full range of contents for which approval is requested. Thus parameter values (e.g. U-235 enrichment, multiple assembly types, UO₂ pellet diameter) needed to bound the packaging contents within prescribed limits should be provided. For packages with multiple loading configurations, each

configuration should also be specifically described, including possible partial load configurations. The description of the contents should include:

- (1) the type of materials (e.g. fissile and non-fissile isotopes, reactor fuel assemblies, packing materials and neutron absorbers);
- (2) the physical form and chemical composition of materials (e.g. gases, liquids, and solids as metals, alloys or compounds);
- (3) the quantity of materials (e.g. masses, densities, U-235 enrichment and isotopic distribution); and
- (4) other physical parameters (e.g. geometric shapes, configurations, dimensions, orientation, spacing and gaps).

VII.5. The criticality section of the SAR should include a description of the packaging with emphasis on the design features pertinent to the criticality safety assessment. The features that should be emphasized are:

- (1) the materials of construction and their relevance to criticality safety;
- (2) pertinent dimensions and volumes (internal and external);
- (3) the limits on design features relied on for criticality safety;
- (4) package materials that act as a moderator for neutrons, including hydrogenous materials with a higher hydrogen density than water (polyethylene, plastic wrappers, etc.) or significant quantities of beryllium, carbon or deuterium; and
- (5) other design features that contribute to criticality safety (e.g. those that prevent in-leakage of water subject to conditions of paras 677 and/or 680(b), as appropriate).

VII.6. The portion of the packaging and contents that forms the confinement system should be carefully described. A statement of tests which have been performed (or analysed), together with the results or evidence of the tests, should be provided to establish the effects on the package (and confinement system) of the normal conditions of transport (see para. 681(b)) and the accident conditions of transport (see para. 682(b)). For packages transported by air, the effects of any tests required in para. 680(a) should be considered. Any potential change to the physical or chemical form of the contents as well as the contingencies of para. 671(a) should be considered in reviewing the test results.

CRITICALITY SAFETY ANALYSIS MODELS

VII.7. The description of the contents, packaging, confinement system and the effects due to appropriate testing should be used to formulate the package models

needed for the analysis of criticality safety to demonstrate regulatory compliance with the requirements of paras 671–682. For each evaluation, one or more calculational models may need to be developed. An exact model of the package may not be necessary; a demonstrated bounding model may be adequate. However, the calculational models should explicitly include the physical features important to criticality safety and should be consistent with the package configurations following the tests prescribed in paras 679–682. Any differences (e.g. in dimensions, material, geometry) between the calculational models and the actual package configurations should be identified and justified. Also, the SAR should discuss and explain how identified differences impact the analysis.

VII.8. Four calculational model types may be considered: contents models, single package models, package array models and material escaping models. The contents models should include all geometric and material regions that are within the defined confinement system. Additional calculational models may be needed to describe the range of contents or the various array configurations or damage configurations that should be analysed (see paras VII.40–VII.43).

VII.9. Simplified, dimensioned sketches that are consistent with the engineering drawings should be provided for the models, or portions of the models, as appropriate. Any differences with the engineering drawings, or with other figures in the application, should be noted and explained. For each model, the sketches could be simplified by limiting the dimensional features on each sketch and by providing multiple sketches as needed, with each sketch building on the previous one.

VII.10. The criticality section of the SAR should address dimensional tolerances of the packaging, including components containing neutron absorbers. When developing the calculational models, tolerances that tend to add conservatism (i.e. produce higher reactivity values) should be included. Subtracting the tolerance from the nominal wall thickness should be conservative for array calculations and have no significant effect on the single package calculation.

VII.11. The range of material specifications (including any uncertainties) for the packaging and contents should be addressed in the criticality section of the SAR. Specifications and uncertainties for all fissile materials, neutron absorbing materials, materials of construction and moderating materials should be consistent with the engineering drawings of the packaging or the specified contents criteria. The range of material specifications and associated uncertainties should be used to select parameters that produce the highest reactivity according to the requirements of para. 673. For example, for each calculational model, the atom density of any neutron

absorber (e.g. boron, cadmium or gadolinium) added to the packaging for criticality control should be limited to that verified by chemical analysis or neutron transmission measurements as per para. 501.

VII.12. In practice, the effect of small variations in dimensions or material specifications may also be considered by determining a reactivity allowance that covers the reactivity change due to the parameter changes under consideration. This additional reactivity allowance should be positive.

VII.13. It would be helpful to include a table that identifies all different material regions in the criticality safety calculational models. This table should list the following, as appropriate, for each region: the material, the density of the material, the constituents of the material, the weight per cent and atom density of each constituent, the region mass represented by the model, and the actual mass of the region (consistent with the contents and packaging description discussed in paras VII.3–VII.6).

METHOD OF ANALYSIS

VII.14. The SAR should provide sufficient information or references to demonstrate that the computer code, nuclear cross-section data and technique used to complete the criticality safety assessment are adequate. The computer codes used in the safety assessment should be identified and described in the SAR, or adequate references should be included. Verification that the software is performing as expected is important. The SAR should identify or reference all hardware and software (titles, versions, etc.) used in the calculations as well as pertinent version control information. Correct installation and operation of the computer code and associated data (e.g. cross-sections) should be demonstrated by performing and reporting the results of the sample problems or general validation problems provided with the software package. Capabilities and limitations of the software that are pertinent to the calculational models should be discussed, with particular attention to discussing limitations that may affect the calculations.

VII.15. Computational methods that directly solve forms of the Boltzmann transport equation to obtain k_{eff} are preferred for use in the criticality safety analysis. The deterministic discrete ordinates technique and the Monte Carlo statistical technique are the typical solution formulations used by most criticality analysis codes. Monte Carlo analyses are prevalent because these codes can better model the geometry detail needed for most criticality safety analyses. Well documented and well validated computational methods may require less description than a limited-use and/or unique

computational method. The use of codes that solve approximations to the Boltzmann equation (e.g. diffusion theory) or use simpler methods to estimate k_{eff} should be justified.

VII.16. When using a Monte Carlo code, the criticality safety assessor should consider the imprecise nature of the k_{eff} value provided by the statistical technique. Every k_{eff} value should be reported with a standard deviation, s . Typical Monte Carlo codes provide an estimate of the standard deviation of the calculated k_{eff} . For some situations, the analyst may wish to obtain a better estimate for the standard deviation by repeating the calculation with different valid random numbers and using this set of k_{eff} values to determine s . Also, the statistical nature of Monte Carlo methods makes them difficult to use in determining small changes in k_{eff} due to problem parameter variations. The change in k_{eff} due to a parameter change should be statistically significant to indicate a trend in k_{eff} .

VII.17. The geometry model limitations of deterministic, discrete ordinates methods typically restrict their applicability to calculation of bounding, simplified models and investigation of the sensitivity of k_{eff} to changes in system parameters. These sensitivity analyses can use a model of a specific region of the full problem (e.g. a fuel pin or homogenized fissile material unit surrounded by a detailed basket model) to demonstrate changes in reactivity with small changes in model dimensions or material specification. Such analyses should be used when necessary to ensure or demonstrate that the full package model has utilized conservative assumptions relative to calculation of the system k_{eff} value. For example, a one dimensional fuel pin model may be used to demonstrate the reactivity effect of tolerances in the clad thickness.

VII.18. The calculational method consists of both the computer code and the neutron cross-section data used by the code. The criticality safety assessment should be performed using cross-section data that are derived from measured data involving the various neutron interactions (e.g. capture, fission and scatter). Unmodified data processed from compendiums of evaluated nuclear data should be considered as the general sources of such data. The source of the cross-section data, any processing performed to prepare the data for analysis, and any pertinent references that document the content of the cross-section library and its range of applicability should be traceable through the SAR. Known limitations that may affect the analyses should be discussed (e.g. omission or limited range of resonance data, limited order or scattering).

VII.19. The SAR should provide a discussion to help ensure that the k_{eff} values calculated by the code are suitably accurate. Adequate problem dependent treatment of multigroup cross-sections, use of sufficient cross-section energy groups (multigroup) or data points (continuous energy), and proper convergence of the

numerical results are examples of issues the applicant may need to review and discuss in the SAR. To the degree allowed by the code, the applicant should demonstrate or discuss any checks made to confirm that the calculational model prepared for the criticality safety analysis is consistent with the code input. For example, code generated plots of the geometry models and outputs of material masses by region may be beneficial in this confirmation process.

VII.20. The statistical nature of Monte Carlo calculations causes there to be few rules, criteria or tests for judging when calculational convergence has occurred; however, some codes do provide guidance on whether convergence has occurred. Thus the analyst may need to discuss the code output or other measures used to confirm the adequacy of convergence. For example, many Monte Carlo codes provide output edits that should be reviewed to determine adequate convergence. In addition, all significant code input parameters or options used in the criticality safety analysis should be identified and discussed in the SAR. For a Monte Carlo analysis, these parameters should include the neutron starting distribution, the number of histories tracked (e.g. number of generations and particles per generation), boundary conditions selected, any special reflector treatment, any special biasing option, etc. For a discrete ordinates analysis, the spatial mesh used in each region, the angular quadrature used, the order of scatter selected, the boundary conditions selected, and the flux and/or eigenvalue convergence criteria should be specified.

VII.21. Code documentation as well as literature references [VII.7, VII.8] are sources of information to obtain practical discussions on the uncertainties associated with Monte Carlo codes used to calculate k_{eff} and advice on output features and trends that should be observed. If convergence problems were encountered by the applicant, a discussion of the problem and the steps taken to obtain an adequate k_{eff} value should be provided. For example, calculational convergence may be achieved by selecting a different neutron starting distribution or running additional neutron histories. Modern personal computers and workstations allow a significant number of particle histories to be tracked.

VALIDATION OF CALCULATIONAL METHOD

VII.22. The application for approval of a transportation package should demonstrate that the calculational method (codes and cross-section data) used to establish criticality safety has been validated against measured data that can be shown to be applicable to the package design characteristics. The validation process should provide a basis for the reliability of the calculational method and should justify the value that is considered the subcritical limit for the packaging system.

VII.23. Available guidance [VII.5, VII.9] for performing and documenting the validation process indicates that:

- (1) bias and uncertainties should be established through comparison with critical experiments that are applicable to the package design;
- (2) the range of applicability for the bias and uncertainty should be based on the range of parameter variation in the experiments;
- (3) any extension of the range of applicability beyond the experimental parameter field should be based on trends in the bias and uncertainty as a function of the parameters and use of independent calculational methods; and
- (4) an upper subcritical limit for the package should be determined on the basis of the established bias and uncertainties and a margin of subcriticality.

VII.24. Although significant reference material is available to demonstrate the performance of many different criticality safety codes and cross-section data combinations, the SAR should still demonstrate that the specific (e.g. code version, cross-section library and computer platform) calculational method used by the applicant is validated in accordance with the above process and taking into account the requirements for quality assurance at all stages of the assessment.

VII.25. The first phase in the validation process should be to establish an appropriate bias and uncertainty for the calculational method by using well defined critical experiments that have parameters (e.g. materials, geometry) that are characteristic of the package design. The single package configuration, the array of packages, and the normal and accident conditions of transport should be considered in selecting the critical experiments for the validation process. Ideally, the set of experiments should match the package characteristics that most influence the neutron energy spectrum and reactivity. These characteristics include:

- (1) the fissile isotope (U-233, U-235, Pu-239 and Pu-241 according to the definition of para. 222), and the form (homogeneous, heterogeneous, metal, oxide, fluoride, etc.) and isotopic composition of the fissile material;
- (2) hydrogenous moderation consistent with optimum conditions in and between packages (if substantial amounts of other moderators such as carbon or beryllium are in the package, these should also be considered);
- (3) the type (e.g. boron, cadmium), placement (between, within or outside the contents) and distribution of absorber material and materials of construction;
- (4) the single package contents configuration (e.g. homogeneous or heterogeneous) and packaging reflector material (lead, steel, etc.); and
- (5) the array configuration including spacing, interstitial material and number of packages.

VII.26. Unfortunately, it is unlikely that the complete combination of package characteristics will be found from available critical experiments, and critical experiments for large arrays of packages do not currently exist. Thus a sufficient variety of critical experiments should be modelled in order to adequately demonstrate that the calculational method predicts k_{eff} to within acceptable standards for each individual experiment. The experiments selected should have characteristics that are judged to be important to the k_{eff} of the package (or array of packages) under normal and accident conditions.

VII.27. The critical experiments that are selected should be briefly described in the SAR, with references provided for detailed descriptions. The SAR should indicate any deviation from the reference experiment description, including the basis for such deviations (discussions with experimenter, experiment log books, etc.). Since validation and supporting documentation may result in a voluminous report, it is typically acceptable to summarize the results in the SAR and reference the validation report.

VII.28. For validation using critical experiments, the bias in the calculational method is the difference between the calculated k_{eff} value of the critical experiment and unity (1.0, although experimental errors and the use of extrapolation may be taken into consideration). Typically, a calculational method is termed to have a positive bias if it overpredicts the critical condition (i.e. calculated $k_{\text{eff}} > 1.0$) and a negative bias if it underpredicts the critical condition (i.e. calculated $k_{\text{eff}} < 1.0$). A calculational method should have a bias that has either no dependence on a characteristic parameter or is a smooth, well behaved function of characteristic parameters. Where possible, a sufficient number of critical experiments should be analysed to determine trends that may exist with parameters important in the validation process (e.g. hydrogen-to-fissile ratio (H/X), U-235 enrichment, neutron absorber material). The bias for a set of critical experiments should be taken as the difference between the best fit of the calculated k_{eff} data and 1.0. Where trends exist, the bias will not be constant over the parameter range. If no trends exist, the bias will be constant over the range of applicability. For trends to be recognized they must be statistically significant, both in terms of the calculational uncertainties and the experimental uncertainties.

VII.29. The criticality safety analyst should consider three general sources of uncertainty: uncertainty in the experimental data, uncertainty in the calculational method and uncertainty due to the particular analyst and calculational models. Examples of uncertainties in experimental data are uncertainties reported in material or fabrication data or uncertainties due to an inadequate description of the experimental layout or simply due to tolerances on equipment. Examples of uncertainties in the calculational method are uncertainties in the approximations

used to solve the mathematical equations, uncertainties due to solution convergence and uncertainties due to cross-section data or data processing. Individual modelling techniques, selection of code input options and interpretation of the calculated results are possible sources of uncertainty due to the analyst or calculational model.

VII.30. In general, all of these sources of uncertainty should be integrally observed in the variability of the calculated k_{eff} results obtained for the critical experiments. The variability should include the Monte Carlo standard deviation in each calculated critical experiment k_{eff} value as well as any change in the calculated value caused by the consideration of experimental uncertainties. Thus these uncertainties will be intrinsically included in the bias and uncertainty in the bias. This variation or uncertainty in the bias should be established by a valid statistical treatment of the calculated k_{eff} values for the critical experiments. Methods exist [VII.10] that enable the bias and uncertainty in the bias to be evaluated as a function of changes in a selected characteristic parameter.

VII.31. Calculational models used to analyse the critical experiments or adequate references to such discussions should be provided. Input data sets used for the analysis should be provided along with an indication of whether these data sets were developed by the applicant or obtained from other identified sources (published references, databases, etc.). Known uncertainties in the experimental data should be identified along with a discussion of how (or if) they were included in the establishment of the overall bias and uncertainty for the calculational method. The statistical treatment used to establish the bias and uncertainty should be thoroughly discussed in the application, with suitable references where appropriate.

VII.32. As an integral part of the code validation effort, the range of applicability for the established bias and uncertainty should be defined. The SAR should demonstrate that, considering both normal and accident conditions, the package is within this range of applicability and/or the SAR should define the extension of the range necessary to include the package. The range of applicability should be defined by identifying the range of important parameters and/or characteristics for which the code was (or was not) validated. The procedure or method used to define the range of applicability should be discussed and justified (or referenced) in the application for approval. For example, one method [VII.10] indicates the range of applicability to be the limits (upper and lower) of the characteristic parameter used to correlate the bias and uncertainties. The characteristic parameter may be defined in terms of the hydrogen-to-fissile ratio (e.g. $H/X = 10$ to 500), the average energy causing fission, the ratio of total fissions to thermal fissions (e.g. $F/F_{\text{th}} = 1.0$ to 5.0), the U-235 enrichment, etc.

VII.33. Use of the bias and uncertainty for a package with characteristics beyond the defined range of applicability is endorsed by consensus guidance [VII.5]. This guidance indicates that the extension should be based on trends in the bias as a function of system parameters and, if the extension is large, confirmed by independent calculational methods. However, the applicant should consider that extrapolation can lead to a poor prediction of actual behaviour. Even interpolation over large ranges with no experimental data can be misleading [VII.11]. The applicant should also consider the fact that comparisons with other calculational methods can illuminate a deficiency or provide concurrence; however, given discrepant results from independent methods, it is not always a simple matter to determine which result is 'correct' in the absence of experimental data [VII.12].

VII.34. The criticality safety analyst should recognize that there is currently no consensus guidance on what constitutes a 'large' extension, nor any guidance on how to extend trends in the bias. In fact, it is not just the trend in the bias that the assessor should consider, but the trend in the uncertainties and bias. The paucity of experimental data near one end of a parameter range may cause the uncertainty to be larger in that region. (Note: Any extension of the uncertainty using the method of Lichtenwalter [VII.10] should consider the functional behaviour of the uncertainty as a function of the parameter, not just the maximum value of the uncertainty.) Proper extension of the bias and uncertainty means that the assessor should determine and understand the trends in the bias and uncertainty. The assessor should exercise extreme care in extending the range of applicability and provide a detailed justification for the need for an extension, along with a thorough description of the method and procedure used to estimate the bias and uncertainty in this extended range.

VII.35. The criticality safety section of the SAR should demonstrate how the bias and uncertainty determined from the comparison of the calculational method with critical experiments are used to establish a minimum k_{eff} value (i.e. upper subcritical limit) such that similar systems with a higher calculated k_{eff} are considered to be critical. The following general relationship for establishing the acceptance criteria is recommended:

$$k_c - \Delta k_u \geq k_{\text{eff}} + n\sigma + \Delta k_m$$

where k_c is the critical condition (1.00); Δk_u is an allowance for the calculational bias and uncertainty; Δk_m is a required margin of subcriticality; k_{eff} is the calculated value obtained for the package or array of packages; n is the number of standard deviations taken into account (2 or 3 are common values); and σ is the standard deviation of the k_{eff} value obtained with Monte Carlo analysis.

Thus, the general relation can be rewritten as

$$1.00 - \Delta k_u \geq k_{\text{eff}} + n\sigma + \Delta k_m$$

or

$$k_{\text{eff}} + n\sigma \leq 1.00 - \Delta k_m - \Delta k_u$$

VII.36. The maximum upper subcritical limit (USL) that should be used for a package evaluation is given by

$$\text{USL} = 1.00 - \Delta k_m - \Delta k_u$$

VII.37. As noted previously, the bias can be positive (overpredict critical experiments) or negative (underpredict critical experiments). However, prudent criticality safety practice is to assume the uncertainties as single sided uncertainties that lower the estimate of a critical condition, and so, by definition, are always zero or negative. The Δk_u term used in this section represents the combined value of the bias and uncertainty, and the applicant should normally define this term such that there is no increase in the value of the USL. Thus,

$$\Delta k_u = \begin{cases} \text{absolute value of the combined bias and uncertainty, if the} \\ \text{combined value is negative, or 0, if the combined value of} \\ \text{the bias and uncertainty is positive.} \end{cases}$$

VII.38. The value of the margin of subcriticality Δk_m used in the safety assessment is a matter of judgement, bearing in mind the sensitivity of k_{eff} to foreseeable physical or chemical changes to the package and the availability of an extensive validation study. For example, low enriched uranium systems may have a high k_{eff} value but exhibit almost insignificant changes in this value for conceivable changes in package conditions or fissile material quantities. Conversely, a system of highly enriched uranium may exhibit significant changes in k_{eff} for rather small changes in the package conditions or fissile material quantity. Typical practice for transportation packages is often to use a Δk_m value equal to 0.05 Δk . Although a value of Δk_m lower than 0.05 may be appropriate for certain packages, such lower values require justification based on available validation and demonstrated understanding of the system and the effect of potential changes. The statistical method of Lichtenwalter [VII.10] provides an example of a technique that can be used to demonstrate that the selected value for Δk_m is adequate to the given set of critical experiments used in the validation. A paucity of critical experiment data or the need to extend beyond the range of applicability [VII.5] may indicate the need to increase the margin of subcriticality beyond that typically applied.

VII.39. Information on potentially useful critical experiments, benchmark exercises and generic code validation reports can be found in the literature [VII.10, VII.13–VII.21].

CALCULATIONS AND RESULTS

General aspects

VII.40. This section presents a logical, generic approach to the calculational effort that should be described in the SAR. At least two series of calculational cases should be performed: (1) a series of single package cases according to the requirements of paras 677–680, and (2) a series of array cases according to the requirements of paras 681 and 682. However, the number of calculations that need to be performed for the safety assessment will depend on the various parameter changes and conditions that should be considered, the packaging design and features, the contents, and the potential condition of the package under normal and accident conditions. For the purposes of the safety assessment based on computational methods, the applicant should consider the term ‘subcritical’ (see paras 671 and 679–682) to mean that the calculated k_{eff} value (including any Monte Carlo standard deviation) is less than the USL defined in paras VII.22–VII.39.

VII.41. Calculations representing each of the different possible loading configurations (full and partial load configurations) should be provided in the SAR. A single contents model that will encompass different loading configurations should only be considered if the justification is clear and straightforward. Sufficient calculations are needed to demonstrate that the fissile contents of a package are being considered in their most reactive configuration consistent with their physical and chemical form within the confinement system and the normal or accident conditions of transport, as appropriate. If the contents can vary over some parameter range (mass, enrichment, isotopic distribution, spacing, etc.), the criticality safety analysis should demonstrate that the model describes and uses the parameter specification that provides the maximum k_{eff} value for the conditions specified in paras 671–682. The content parameter values and/or content configurations that provide the maximum reactivity may vary depending on whether a single package or an array of packages is being analysed.

VII.42. Heterogeneous mixtures of fissile material should assume an optimum spacing between fissile lumps such that maximum reactivity is achieved unless adequate structure is provided to ensure a known spacing or spacing range (e.g. reactor fuel pins in an assembly). It is important to realize that, with complex systems,

there are often competing factors and that uniform spacing may not be the most reactive state possible. The contents models for packages that transport individual pellets should ensure that credible variations in pellet size and spacing are considered in reaching the optimum configuration that produces the maximum reactivity. Packages that transport waste containing fissile material should ensure that the limiting concentration of fissile material is used in the safety analysis. As required in para. 673, uncertainty in the contents must be covered by setting the relevant parameter to its most conservative value (consistent with the range of possible values); in practice this may be achieved by including it in the consideration of the allowance for calculational uncertainties.

VII.43. With the number of calculations that may be needed, it is helpful to summarize the calculated results in a tabular form with a case identifier, a brief description of the conditions for each case, and the case results. Additional information should be included in the table if it supports and simplifies the verbal description in the text. Dyer [VII.22] includes an example of a format recommended to summarize the results of single package and package array calculations. A similar format could be used to summarize the results for cases demonstrating that the limiting conditions are appropriately applied.

Single package analyses

VII.44. The single package analyses used to demonstrate subcriticality for the purposes of paras 679 and 680 should depict the packaging and contents in the most reactive configuration consistent with the chemical and physical form of the material and the requirement to consider (para. 679) or not consider (para. 680(a)) in-leakage of water. As indicated above, other single package analyses may be needed to demonstrate intermediate configurations analysed to determine the most reactive configuration. Determination of the most reactive configuration should consider: (1) the change in internal and external dimensions due to impact; (2) loss of material, such as neutron shield or wooden overpack, due to the fire test; (3) rearrangement of fissile material or neutron absorber material within the confinement system due to impact, fire or immersion; and (4) the effects of temperature changes on the package material and/or the neutron interaction properties.

VII.45. Unless the special features of para. 677 are provided, calculations for the single package should systematically investigate the various states of water flooding and package reflection (according to the requirement of para. 678) representative of the normal and accident conditions of transport. If a package has multiple void regions, including regions within the confinement or containment system, flooding each region (and/or combinations of regions) should be considered. The case of the

single package completely flooded and reflected should be considered. Variations in the flooding sequence should be considered by the applicant (e.g. partial flooding, variations caused by the package lying in horizontal or vertical orientations, flooding (moderating) at less than full density water, progressively flooding regions from the inside out).

VII.46. Paragraph 678 requires that in the assessment needed for para. 679 the confinement system be reflected closely on all sides by at least 20 cm of full density water unless packaging materials that surround the confinement system provide for a higher k_{eff} . Thus, for routine and normal conditions, analyses that consider confinement system reflection by water and package reflection by water must be carried out to ascertain the condition of highest k_{eff} . For the accident conditions of transport, if the confinement system is demonstrated to remain within the package, reflection of the confinement system by water can be precluded and only water reflection of the package considered. A lead shield around the confinement system is an example of a packaging reflector that may provide greater reflection than water.

VII.47. Several single package analyses may be needed to assess the requirement of para. 680 for packages to be transported by air, particularly if actual testing per paras 733 and 734 is not performed. In the absence of the appropriate tests, these analyses should be formulated to demonstrate that no arrangement could arise where the single package could be critical, assuming no addition of water to the package materials. The results of the single package calculations can influence the approach and the number of calculations required for the array series calculations, particularly if there are different content loading configurations.

Assessment of package arrays

VII.48. The package array models should depict the arrangements of packages that are used in the calculations necessary to fulfil the requirements of paras 681 and 682. At least two array models are needed: an array of undamaged packages consistent with the normal conditions of transport and an array of damaged packages following the accident conditions of transport. The configuration of the individual packages (undamaged and damaged) used in the respective array models should be consistent with (but not necessarily identical to) the respective single package models discussed in paras VII.44–VII.47 (e.g. leakage needs to be minimized in the single package model as does interaction in the array model).

VII.49. The treatment of array moderation can be easy or complex, depending on the placement of the materials of construction and their susceptibility to damage from accident conditions. For all of these conditions and combinations of conditions, the

assessor should carefully investigate the optimum degree of internal and interspersed moderation consistent with the chemical and physical form of the material and the packaging for normal and accident conditions of transport, and demonstrate that subcriticality is maintained. Numerous moderation conditions should be considered, such as:

- (1) moderation from packing materials that are inside the primary containment system;
- (2) moderation due to preferential flooding of different void regions in the packages;
- (3) moderation from materials of construction (e.g. thermal insulation and neutron shielding); and
- (4) moderation in the region between the packages in an array.

VII.50. Under normal conditions of transport, the analyses should consider only the moderators present in the package (items (1) to (3) above); moderation between packages (item (4) above) from mist, rain, snow, foam, flooding, etc., should not be considered according to the specifications of para. 681. In determining the criticality safety index (CSI) of an array of damaged packages, the applicant should carefully consider all four of the above conditions, including how each form of moderation can change. As an example, consider a package with thermally degradable insulation and thermal neutron poison material. For the normal conditions of transport, the analysis should include the insulation. For the accident conditions, the applicant should investigate the effects of reduced moderation as a result of the thermal test. If the inner containment system of this example package does not prevent water in-leakage, the applicant should carefully evaluate the varying degrees of moderation in the containment. The effect that the neutron poison has on the system reactivity will also change as the degree of moderation varies.

VII.51. Optimum moderation should be considered in each calculation unless it is demonstrated that there would be no leakage of water into void spaces under the appropriate test conditions. Optimum moderation is the condition that provides the maximum k_{eff} value for the array (this is likely to be a different degree of moderation than for the optimum single package condition). Partial and preferential flooding should be considered in determining optimum moderation conditions. If there is no leakage of water into the system, the actual internal moderation provided by the materials in the package can be assumed in the array model. Similarly, if the moderator provides more than optimum moderation and by its physical and chemical form cannot leak from the containment vessel, then its moderating properties can be considered in the model. For example, a solid moderator which is shown to overmoderate the fissile material can be considered in the calculational

model if its presence is verified. This criterion on moderation should be assessed and separately applied for normal conditions of transport and accident conditions of transport.

VII.52. Each model for arrays of undamaged packages should assume a void between the packages consistent with the requirement of para. 681(a). For the assessment of arrays of damaged packages according to para. 682, this optimum interspersed hydrogenous moderation condition should be determined. Optimum is considered the hydrogenous condition that provides the highest k_{eff} value. Interspersed moderation should be considered that moderation which separates one package in the array from another package. This interspersed moderation should not be taken to include the moderation within the package. Thus, if the packaging provides interspersed moderation greater than that shown to be optimum, the greater amount may be assumed in the calculational model.

VII.53. The sensitivity of the neutron interaction between packages varies with the package design. For example, small, lightweight packages are more susceptible to high neutron interaction than large, heavy packages (e.g. irradiated nuclear fuel packages). Since variations in internal water moderation and interspersed water need to be considered for each arrangement of packages, the process can be tedious without proper experience to guide the selection of analyses. It is helpful to provide a plot of the k_{eff} value as a function of the moderator density between packages.

VII.54. In preparing this plot, the first step is to determine the optimum moderation of the array of packages consistent with the results of the accident tests. As water is added to the region between packages, the spacing of the packages may limit the quantity of moderator that can be added. For this reason, it is sometimes convenient to model an infinite array of packages using an array unit cell consisting of the individual package and a tight fitting repeating boundary. If the k_{eff} response to increasing interspersed moderator density for this array with the units in contact has an upward trend (positive slope) at full density moderation, the applicant should consider increasing the size of the unit cell and recalculating k_{eff} as a function of moderation density. Increasing the size of the unit cell provides an increased edge-to-edge spacing between packages and makes more volume available for the interspersed moderator. This progressive procedure should only be stopped after confirming that the packages are isolated and added interstitial water is only providing additional water reflection.

VII.55. All credible combinations of density and spacing variation that may cause a higher k_{eff} value to be calculated should be considered, and a discussion should be provided in the Safety Assessment Report (SAR) demonstrating that the maximum k_{eff}

value has been determined. Figure VII.1 depicts some examples of plots of k_{eff} versus interspersed water moderator density illustrating the moderation, absorption and reflection characteristics that may be encountered in packaging safety assessments. Curves A, B, and C represent arrays for which an array of packages is overmoderated and increasing water moderation only lowers (curves B and C), or has no effect (curve A) on, the k_{eff} value. Curves D, E and F represent arrays for which the array is undermoderated at zero water density, and increasing the interspersed moderator density causes the k_{eff} value to increase. Then, as the water density increases further, neutron absorption comes into effect, neutron interaction between packages decreases, and the k_{eff} value levels out (curve D) or decreases (curves E and F). These peaking effects such as seen in curves E and F can occur at very low moderator density (e.g.

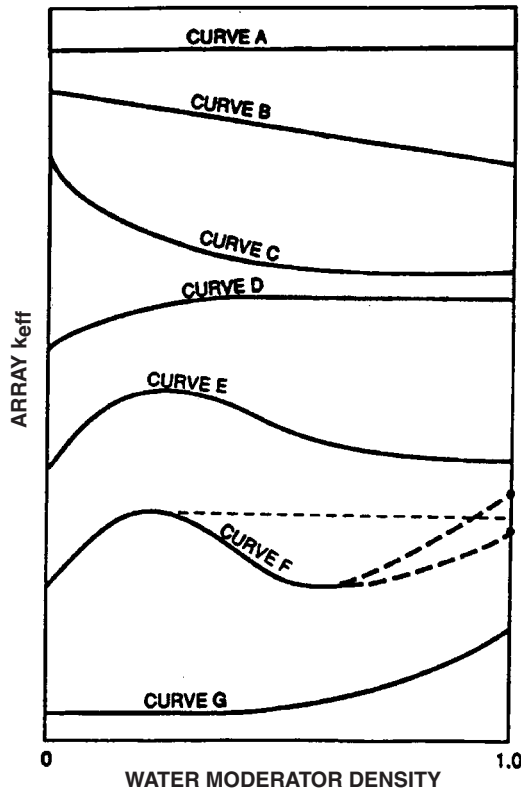

FIG. VII.1. Typical plots of array k_{eff} versus interspersed water moderator density.

0.001 to 0.1 fraction of full density). Therefore, care should be taken when selecting the values of interspersed moderator density to calculate in the search for the maximum k_{eff} value. It should be noted that the single package calculation only requires 20 cm of water reflection; thus, for a well spaced array (more than 20 cm), the accident condition array may produce a higher k_{eff} for an individual package than the single package model (this depends on the effects of paras 677 and 678). Curve G represents an array where the optimum interspersed moderator density has not been achieved even with full water density. For this situation, the applicant should increase the centre-to-centre spacing of the packages in the array, and all cases should be recalculated.

VII.56. The objective of the package array calculations is to obtain the information needed to determine the CSI for criticality control as prescribed in para. 528. The assessor may consider beginning the array calculations with an infinite array model. Successively smaller finite arrays may be required until the array sizes for normal and accident conditions of transport are found to be below the USL. As an alternative, an applicant may initiate the analyses using any array size — for example, one that is based on the number of packages planned to be shipped on a vehicle.

VII.57. Care should be taken that the most reactive array configuration of packages has been considered in the criticality safety assessment. In investigating different array arrangements, the competing effects of leakage from the array system and interaction between packages in the array should be considered. Array arrangements that minimize the surface-to-volume ratio decrease leakage and should, in simplistic terms, maximize k_{eff} . Preferential geometric arrangement of the packages in the array should be considered. For example, for some packages (e.g. with the fissile material loaded off-centre) the need to optimize the interaction may mean that an array is more reactive when packages are grouped in a single or double layer. The effect of the external water reflector also needs to be considered. For some array cases, there may be little moderator present within the array, so increasing the surface area may lead to more moderation and, possibly, higher reactivity. The exact package arrangement may be represented by a simplified arrangement if adequate justification is provided. For example, it has been shown that a triangular pitch arrangement of packages can in simple cases be represented by using an appropriately modified package model within a square pitch lattice arrangement [VII.22]. In more complex cases (even for cuboidal packages), the effect of having a triangular pitch may be important since interaction between three triangularly pitched packages could be a dominating factor. Since there are so many competing effects, any simplifications made in the assessment need to be justified; something which is obvious from the point of view of array leakage may not be as obvious from the point of view of package interaction. All finite arrays of packages should be reflected on all sides by a close fitting, full density water reflector at least 20 cm thick.

VII.58. The CSI should be determined using the prescription of para. 528 and the information from the array analyses on the number of packages that will remain subcritical (below the USL) under normal and accident conditions.

SPECIAL ISSUES

VII.59. Designers seeking to reduce conservatism in the criticality safety aspects of transportation packages must carefully consider criticality safety issues throughout the entire design process. The large number of variables that can be important may lead to a very large number of calculations. It is, therefore, in the interests of the assessor to interact effectively with other members of the package design and manufacturing team in order to reduce the variables that need to be considered in the assessment and to assure adequate input on criticality safety issues. The difficulty in reducing the bounding conservatism traditionally used in criticality safety often arises in confirming the performance of the package under accident conditions and demonstrating the effect that this performance would have on criticality safety. Interaction with members of the design team responsible for structural, material and containment aspects of the package design is essential in order for the criticality safety analyst to obtain the knowledge required for making defensible assumptions for the calculational model. The experience and knowledge of the criticality safety assessor is also crucial to assuring that an efficient, yet complete assessment is performed and documented.

VII.60. Design options that depend on limiting mass, dimensions or concentration are often needed for safety, but are often a low priority design option because of payload reductions. Similarly, control by separation of fissile material takes too much valuable package space. The design option to provide special features to prevent water in-leakage is an attractive alternative to eliminate the consideration of water in a criticality assessment, but the design and demonstration of special features can be very difficult and lead to a prolonged review process. Thus, use of fixed neutron poisons remains the major option to help assure criticality safety. To increase loadings for the large quantities of irradiated nuclear fuel (INF) being transported, nuclear fuel isotopes resulting from irradiation can be used as an alternative to the fresh (unirradiated) isotopic values used in the traditional, bounding approach to criticality safety assessment of INF packages.

Credit for irradiation history (burnup credit)

VII.61. A principal mandate for packages containing fissile material is to ensure subcriticality. Thus for packages where thermal, structural, weight, containment or radiation protection are the design limiting issues, there is every incentive to keep the

assumptions used in the design basis analysis as simple and as bounding as possible as long as the package design is constrained by other technical issues. For the transport of irradiated (e.g. irradiated to near design burnup) nuclear fuel, the traditional design basis has been to use the isotopic compositions of the fresh, unirradiated fuel in the criticality safety evaluation. This approach is straightforward, relatively easy to defend, and provides a conservative margin that typically precludes most concerns about misloading events.

VII.62. Transportation of INF with longer cooling times and the need to consider higher initial enrichments have caused criticality safety to become a more limiting design issue for INF packages. Thus, to handle increased INF capacity in new designs and to enable higher initial enrichments in existing packages, the concept of taking credit for the reduced reactivity caused by the irradiation or burnup of the INF becomes an attractive design alternative to the fresh fuel assumption. The concept of considering the change in fuel inventory, and thus a reduction in reactivity, due to INF burnup is referred to as 'burnup credit'. Although the fact that INF has a decreased reactivity over fresh fuel is not questioned, several issues must be addressed and resolved before using irradiated fuel isotopics in the design basis analyses for the criticality safety evaluation. These issues include:

- (1) validation of analysis tools and associated nuclear data to demonstrate their applicability in the area of burnup credit;
- (2) specification of design basis analyses that ensures prediction of a bounding value of k_{eff} ; and
- (3) operational and administrative controls that ensure the INF loaded into a package has been verified to meet the loading requirements specified for that package design.

VII.63. The use of INF isotopics in the criticality safety analysis means that any computational methods used to predict the isotopics should be validated, preferably against measured data. The reduced reactivity in INF is due to the decrease in fissile inventory and the increase in parasitic, neutron absorbing nuclides (non-fissile actinides and fission products) that build up during burnup. Broadhead [VII.23] and DeHart [VII.24] provide information to help identify the important nuclides that affect the reactivity of PWR irradiated fuel. The INF nuclides that can be omitted from a safety analysis are the parasitic absorbers that can only decrease k_{eff} further if included in the analysis. Neutron absorbers that are not intrinsic to the fuel material matrix (gases, etc.) must also be eliminated.

VII.64. After selection of the nuclides to be used in the safety analysis, the validation process must begin. Compendiums of measured isotopic data have been produced

[VII.25–VII.27], and efforts have been made to validate computational methods using data selected from these compendiums [VII.27–VII.29]. The measured isotopic data that are available for validation are limited. Of further concern is the fact that the database of fission product measurements is a small subset of the actinide measurements. In addition, the cross-section data for fission product nuclides have had much less scrutiny over broad energy ranges than most actinides of importance in INF. Fission products can provide 20–30% of the negative reactivity from burnup, yet the uncertainties in their cross-section data and isotopic predictions reduce their effectiveness in safety assessments with burnup credit.

VII.65. The use of INF isotopics has also raised validation issues relative to the performance of computational methods to predict k_{eff} . The concerns originate from the fact that no critical experiments using irradiated fuel in a transport package environment have been openly reported. Experimental data using actual irradiated fuel are desired in order to demonstrate that the nuclide cross-sections not occurring in fresh fuel are adequate for the prediction of k_{eff} , that the variation in isotopic composition and its influence on k_{eff} can be adequately modelled, and that the physics of particle interaction in INF is handled adequately by the analysis methodology. Sufficient relevant experimental data [VII.30–VII.33] should be considered to provide a basis for the validation of calculational methods applied in the SAR of a package using burnup credit as a design basis assumption. Calculational benchmark exercises [VII.34–VII.36] that compare independent computational methods and data can also be valuable aids in understanding technical issues and identifying potential causes for differences between predicted and measured data.

VII.66. The understanding of modelling and parameter uncertainties, together with proper incorporation of these uncertainties in the analysis assumptions, is necessary so that a bounding value of k_{eff} is calculated for a packaging SAR that applies burnup credit. Many of these uncertainties should be examined as part of the validation process. For example, DeHart [VII.24] discusses a procedure to incorporate the variability in the analysis of measured isotopic data and the number of data points to provide a ‘correction’ factor that adjusts the INF isotopics such that a conservative estimate of k_{eff} can be calculated.

VII.67. The nuclide composition of a particular fuel assembly in a reactor is dependent, to varying degrees, on the initial nuclide abundance, the specific power, the reactor operating history (including moderator temperature, soluble boron, and assembly location in the reactor), the presence of burnable poisons or control rods, and the cooling time after discharge. Seldom, if ever, are all the irradiation parameters known to the safety analyst; typically the analyst will have to demonstrate the criticality safety of a package for a specified initial enrichment, burnup, cooling time

and assembly type. Data on the specific power, operating history, axial burnup distribution and presence of burnable poisons must be selected to ensure that the calculated INF compositions will produce conservative estimates of k_{eff} . Identification of important reactor history parameters and their effect on INF reactivity have been discussed by DeHart [VII.24], DeHart and Parks [VII.37] and Bowden [VII.38]. Similarly, DeHart and Parks [VII.37, VII.24] discuss the effect of the uncertainty in the axial burnup profile and present information on the detail required in both the axial isotopic distribution and the numerical input parameters (number of neutron histories, etc.) in order to predict a reliable value of k_{eff} .

VII.68. The use of bounding uncertainties in the validation process and the analysis assumptions should provide assurance that the safety analysis is conservative for the range of initial enrichment, burnup, cooling time and assembly type. For a given assembly type and minimum cooling time (reactivity decreases with cooling time for the first 100 years or so), the safety analysis could provide a loading curve (see Fig. VII.1) indicating the region of burnup/initial enrichment that ensures subcriticality.

DESIGN AND OPERATIONAL ISSUES

Use of neutron poisons

VII.69. Traditionally, neutron absorbing materials are divided into two categories: materials of construction and neutron poisons. Materials of construction are usually guaranteed always to be present by virtue of their function. For this reason the criticality assessor should ensure that the assessment is in conformance with the as-built package and that future modifications are reviewed and addressed for potential criticality issues. Fixed neutron poisons, on the other hand, are intentionally added, specifically for the purpose of absorbing neutrons to reduce neutron reactivity or to limit neutron reactivity increases during abnormal conditions. The principal concern with relying on neutron absorption by poisons (as opposed to relying on neutron absorption by the materials of construction) is ensuring its presence. Therefore, special attention is always required to guarantee both its presence and the proper distribution of the neutron absorbing material over the assumed lifetime of the package. Physical, chemical and corrosive mechanisms must be considered as potential mechanisms for absorber loss. Loss of absorber material through direct neutron absorption (and, thus, transmutation to a non-absorbing isotope) is typically inconsequential because any measurable depletion would take millions of years of routine operation due to extremely low flux levels in a subcritical system.

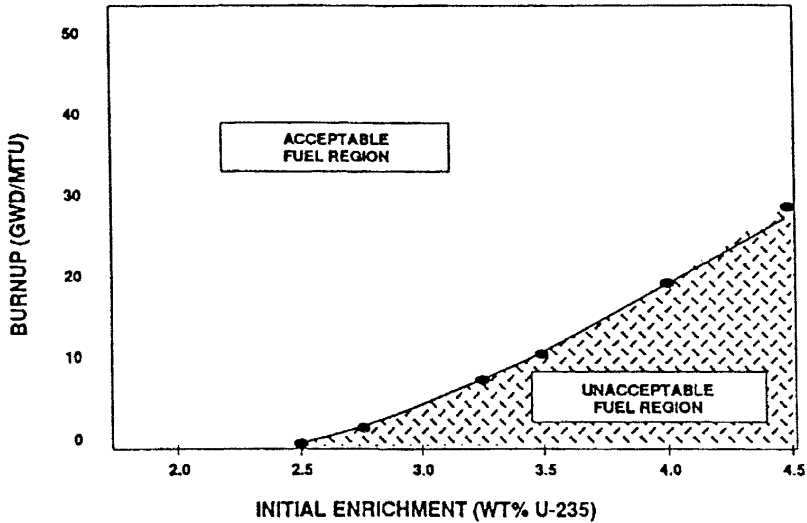

FIG. VII.2. Hypothetical loading curve.

VII.70. When neutron poisons are necessary, it is advisable to incorporate them as intrinsically as possible into the normal materials of construction and verify their presence by a measurement. For example, boron fixed in an aluminium or steel matrix could be used for the inner container (basket) to reduce the neutron interaction between packages (provided it is structurally/thermally acceptable), or cadmium could be plated on to the inside surface of the inner container. However, verifying (and perhaps, reverifying at some frequency) that the absorbers are indeed present, in the prescribed quantity and distribution, is a requirement (see paras 501 and 502) that must be addressed in the SAR.

VII.71. If subcriticality of the shipment is dependent upon the presence of neutron absorbing materials that are an integral part of the contents (e.g. fissile waste with known absorbers or control rods in a fuel assembly), the burden of proof that the materials are present during normal and accident conditions is an important safety issue.

Pre-shipment measurements

VII.72. When burnup credit is used in the package assessment, operational and administrative controls are needed to establish that the INF being loaded in the package is within the characteristics used to perform the safety evaluation. In para. 674(b) a measurement is called for, and it is appropriate to link the assessment to this measurement. The assessment should show that the measurement is adequate

for the purpose intended, taking into account the margins of safety and the probability of error; see paras 674.1–674.4. The measurement technique should depend on the likelihood of misloading the fuel and the amount of available subcritical margin due to irradiation.

VII.73. An example of variability in measurement technique is provided by France, which currently specifies the use of a simple gamma detector measurement to verify burnup credit allowances for less than 5600 MW-d/MTU but more direct measurement of fuel burnup for allowance of higher irradiation [VII.39]. For this second measurement, France relies on two instruments that verify the reactor burnup records based on active and passive neutron measurements. In the USA a measurement device similar to one used in France has been demonstrated by Ewing [VII.40, VII.41] to be a practical method for determining if an assembly is within the ‘acceptable fuel region’ of Fig. VII.2. If the axial burnup profile is identified as an important characteristic of the spent nuclear fuel that is relied upon in the safety analysis, then similar measurement devices could also potentially be used to ascertain that the profile is within defined limits.

REFERENCES TO APPENDIX VII

- [VII.1] PRUVOST, N.L., PAXTON, H.C., Nuclear Criticality Safety Guide, Rep. LA-12808, Los Alamos National Laboratory, Los Alamos, NM (1996).
- [VII.2] THOMAS, J.T., Ed., Nuclear Safety Guide TID-7016, Revision 2, Rep. NUREG/CR-0095 (ORNL/NUREG/CSD-6), US Nuclear Regulatory Commission, Washington, DC (1978).
- [VII.3] PAXTON, H.C., PRUVOST, N.L., Critical Dimensions of Systems Containing ^{235}U , ^{239}Pu , and ^{233}U , Rep. LA-10860-MS, Los Alamos National Laboratory, Los Alamos, NM (1987).
- [VII.4] JAPAN ATOMIC ENERGY RESEARCH INSTITUTE, Nuclear Criticality Safety Handbook (English Translation), JAERI-Review-95-013, JAERI, Tokyo (1995).
- [VII.5] AMERICAN NATIONAL STANDARDS INSTITUTE, American National Standard for Nuclear Criticality Safety in Operations with Fissionable Materials Outside Reactors, ANSI/ANS-8.1-1983 (Reaffirmed 1988), American Nuclear Society, LaGrange Park, IL (1983).
- [VII.6] AMERICAN NATIONAL STANDARDS INSTITUTE, American National Standard for Nuclear Criticality Control of Special Actinide Elements, ANSI/ANS-8.15-1981, American Nuclear Society, LaGrange Park, IL (1981).
- [VII.7] LANDERS, N.F., PETRIE, L.M., “Uncertainties associated with the use of the KENO Monte Carlo criticality codes”, Safety Margins in Criticality Safety (Int. Top. Mtg San Francisco, 1989), American Nuclear Society, LaGrange Park, IL (1989) 285.

- [VII.8] FORSTER, R.A., et. al., "Analyses and visualization of MCNP criticality results", Nuclear Criticality Safety (ICNC'95) (Proc. Int. Conf. Albuquerque, 1995), Vol. 1, Univ. of New Mexico, Albuquerque, NM (1995) 6–160.
- [VII.9] INTERNATIONAL ORGANIZATION FOR STANDARDIZATION, Nuclear Energy — Fissile Materials — Principles of Criticality Safety in Storing, Handling, and Processing, ISO-1709, ISO, Geneva (1995).
- [VII.10] LICHTENWALTER, J.J., BOWMAN, S.M., DEHART, M.D., Criticality Benchmark Guide for Light-Water-Reactor Fuel in Transportation and Storage Packages, Rep. NUREG/CR-6361 (ORNL/TM-13211), US Nuclear Regulatory Commission, Washington, DC (1997).
- [VII.11] PARKS, C.V., WRIGHT, R.W., JORDAN, W.C., Adequacy of the 123-Group Cross-Section Library for Criticality Analyses of Water-moderated Uranium Systems, Rep. NUREG/CR-6328 (ORNL/TM-12970), US Nuclear Regulatory Commission, Washington, DC (1995).
- [VII.12] PARKS, C.V., JORDAN, W.C., PETRIE, L.M., WRIGHT, R.Q., Use of metal/uranium mixtures to explore data uncertainties, Trans. Am. Nucl. Soc. **73** (1995) 217.
- [VII.13] KOPONEN, B.L., WILCOX, T.P., HAMPEL, V.E., Nuclear Criticality Experiments From 1943 to 1978, an Annotated Bibliography: Vol. 1, Main Listing, Rep. UCRL-52769, Vol. 1, Lawrence Livermore Laboratory, Livermore, CA (1979).
- [VII.14] BIERMAN, S.R., Existing Experimental Criticality Data Applicable to Nuclear Fuel Transportation Systems, Rep. PNL-4118, Battelle Pacific Northwest Laboratories, Richland, WA (1983).
- [VII.15] ORGANIZATION FOR ECONOMIC COOPERATION AND DEVELOPMENT, International Handbook of Evaluated Criticality Safety Benchmark Experiments, Rep. NEA/NSC/DOC(95)03, Vols I–VI, OECD, Paris (1995).
- [VII.16] DURST, B.M., BIERMAN, S.R., CLAYTON, E.D., Handbook of Critical Experiments Benchmarks, PNL-2700, Battelle Pacific Northwest Laboratories, Richland, WA (1978).
- [VII.17] ORGANIZATION FOR ECONOMIC CO-OPERATION AND DEVELOPMENT, Standard Problem Exercise on Criticality Codes for Spent LWR Fuel Transport Containers, CSNI Rep. No. 71 (Restricted), OECD, Paris (May 1982).
- [VII.18] ORGANIZATION FOR ECONOMIC CO-OPERATION AND DEVELOPMENT, Standard Problem Exercise on Criticality Codes for Large Arrays of Packages of Fissile Materials, CSNI Rep. No. 78 (Restricted), OECD, Paris (August 1984).
- [VII.19] JORDAN, W.C., LANDERS, N.F., PETRIE, L.M., Validation of KENO V.a — Comparison with Critical Experiments, Rep. ORNL/CSD/TM-238, Oak Ridge Natl Lab., Oak Ridge, TN (1994).
- [VII.20] The 1991 International Conference on Nuclear Criticality Safety (ICNC'91) (Proc. Conf. Oxford, 1991), 3 Vols, Oxford, UK (1991).
- [VII.21] The 1995 International Conference on Nuclear Criticality Safety (ICNC'95) (Proc. Conf. Albuquerque, 1995), 2 Vols, Univ. of New Mexico, Albuquerque, NM (1995).
- [VII.22] DYER, H.R., PARKS, C.V., ODEGAARDEN, R.H., Recommendations for Preparing the Criticality Safety Evaluation of Transportation Packages,

- NUREG/CR-5661 (ORNL/TM-11936), US Nuclear Regulatory Commission, Washington, DC (1997).
- [VII.23] BROADHEAD, B.L., DEHART, M.D., RYMAN, J.C., TANG, J.S., PARKS, C.V., Investigation of Nuclide Importance to Functional Requirements Related to Transport and Long-term Storage of LWR Spent Fuel, Rep. ORNL/TM-12742, Oak Ridge Natl Lab., Oak Ridge, TN (1995).
- [VII.24] DEHART, M.D., Sensitivity and Parametric Evaluations of Significant Aspects of Burnup Credit for PWR Spent Fuel Packages, ORNL/TM-12973, Martin Marietta Energy Systems, Inc., Oak Ridge Natl Lab., Oak Ridge, TN (1996).
- [VII.25] NAITO, Y., KUROSAWA, M., KANEKO, T., Data Book of the Isotopic Composition of Spent Fuel in Light Water Reactors, Rep. JAERI-M 94-034, Japan Atomic Energy Research Institute, Tokyo (1994).
- [VII.26] BIERMA, S.R., TALBERT, R.J., Benchmark Data for Validating Irradiated Fuel Compositions Used in Criticality Calculations, Rep. PNL-10045, Battelle Pacific Northwest Laboratories, Richland, WA (1994).
- [VII.27] KUROSAWA, M., NAITO, Y., KANEKO, T., "Isotopic composition of spent fuels for criticality safety evaluation and isotopic composition database (SFCompo)", Nuclear Criticality Safety, ICNC'95 (Proc. 5th Int. Conf. Albuquerque, 1995), Univ. of New Mexico, Albuquerque, NM (1995) 2.11–15.
- [VII.28] HERMANN, O.W., BOWMAN, S.M., BRADY, M.C., PARKS, C.V., Validation of the SCALE System for PWR Spent Fuel Isotopic Composition Analyses, Rep. ORNL/TM-12667, Oak Ridge Natl Lab., Oak Ridge, TN (1995).
- [VII.29] MITAKE, S., SATO, O., YOSHIZAWA, N., "An analysis of PWR fuel post irradiation examination data for the burnup credit study", Nuclear Criticality Safety, ICNC'95 (Proc. 5th Int. Conf. Albuquerque, 1995), Univ. of New Mexico, Albuquerque, NM (1995) 5.18–25.
- [VII.30] BOWMAN, S.M., DEHART, M.D., PARKS, C.V., Validation of SCALE-4 for burnup credit applications, Nucl. Technol. **110** (1995) 53.
- [VII.31] GULLIFORD, J., HANLON, D., MURPHY, M., "Experimental validation of calculational methods and data for burnup credit", Nuclear Criticality Safety, ICNC'95 (Proc. 5th Int. Conf. Albuquerque, 1995), Univ. of New Mexico, Albuquerque, NM (1995).
- [VII.32] SANTAMARINA, A., et al., "Experimental validation of burnup credit calculations by reactivity worth measurements in the MINERVE Reactor", *ibid.*, pp. 1b.19–25.
- [VII.33] ANNO, J., FOUILLAUD, P., GRIVOT, P., POULLOT, G., "Description and exploitation of benchmarks involving ^{149}Sm , a fission product taking part in the burnup credit in spent fuels," *ibid.*, pp. 5.10–17.
- [VII.34] TAKANO, M., OKUNO, H., OECD/NEA Burnup Credit Criticality Benchmark, Result of Phase IIA, NEA/NSC/DOC(96)01, Japan Atomic Energy Research Institute, Tokyo (1996).
- [VII.35] TAKANO, M., OECD/NEA Burnup Credit Criticality Benchmark, Result of Phase IA, Rep. NEA/NSC/DOC(93)22, Japan Atomic Energy Research Institute, Tokyo (1994).

- [VII.36] DEHART, M.D., BRADY, M.C., PARKS, C.V., OECD/NEA Burnup Credit Calculational Criticality Benchmark — Phase IB Results, Rep. NEA/NSC/DOC(96)-06 (ORNL-6901), Oak Ridge National Laboratory, Oak Ridge, TN (1996).
- [VII.37] DEHART, M.D., PARKS, C.V., “Issues Related to Criticality Safety Analysis for Burnup Credit Applications”, Nuclear Criticality Safety, ICNC’95 (Proc. 5th Int. Conf., Albuquerque, 1995), Univ. of New Mexico, Albuquerque, NM (1995) 1b.26–36.
- [VII.38] BOWDEN, R.L., THORNE, P.R., STRAFFORD, P.I., “The methodology adopted by British Nuclear Fuels plc in claiming credit for reactor fuel burnup in criticality safety assessments”, *ibid.*, pp. 1b.3–10.
- [VII.39] ZACHAR, M., PRETESACQUE, P., “Burnup credit in spent fuel transport to COGEMA La Hague reprocessing plant”, *Int. J. Radioact. Mater. Trans.* **5** 2–4 (1994) 273–278.
- [VII.40] EWING, R.I., “Burnup verification measurements at US nuclear utilities using the Fork system”, Nuclear Criticality Safety, ICNC’95 (Proc. 5th Int. Conf. Albuquerque, 1995), Univ. of New Mexico, Albuquerque, NM (1995) 11.64–70.
- [VII.41] EWING, R.I., “Application of a Burnup Verification Meter to Actinide-only Burnup Credit for Spent PWR Fuel”, Packaging and Transportation of Radioactive Materials, PATRAM 95 (Proc. 11th Int. Conf. Las Vegas, 1995), USDOE, Washington, DC (1995).

CONTRIBUTORS TO DRAFTING AND REVIEW

Alter, U.	Bundesministerium für Umwelt, Naturschutz und Reaktorsicherheit, Germany
Baekelandt, L.	NIRAS/ONDRAF, Belgium
Blackman, D.J.	Department of Transport, United Kingdom
Blalock, L.	United States Department of Energy, United States of America
Bologna, L.	Agenzia Nazionale per la Protezione dell' Ambiente, Italy
Boyle, R.A.	United States Department of Transportation, United States of America
Burbidge, G.	Nordion International, Canada
Carrington, C.	Amersham International plc, United Kingdom
Collin, F.W.	Bundesamt für Strahlenschutz, Germany
Cosack, M.	Bundesamt für Strahlenschutz, Germany
Cottens, E.	Ministry of Social Affairs, Public Health and Environment, Belgium
Cousinou, P.	Institut de Protection et de Sûreté Nucléaire, France
Critchley, M.	British Nuclear Fuels plc, United Kingdom
Desnoyers, B.	Cogéma, France
Dicke, G.J.	International Atomic Energy Agency
Droste, B.	Bundesanstalt für Materialforschung und -prüfung, Germany
Ducháček, V.	State Office for Nuclear Safety, Czech Republic
Easton, E.	United States Nuclear Regulatory Commission, United States of America
El-Shinawy, R.	Egyptian Atomic Energy Authority, Egypt

Ershov, V.N.	Ministry of Atomic Energy, Russian Federation
Eyre, P.	Atomic Energy Control Board, Canada
Fasten, C.	Bundesamt für Strahlenschutz, Germany
François, P.	Institut de Protection et de Sûreté Nucléaire, France
Franco, P.	Consejo de Seguridad Nuclear, Spain
Golder, F.	Institute of Isotopes, Hungary
Goldfinch, E.P.	Nuclear Technology Publishing, United Kingdom
Gray, I.L.S.	U.K. NIREX Ltd, United Kingdom
Harding, P.	British Nuclear Fuels plc, United Kingdom
Haughney, C.J.	United States Nuclear Regulatory Commission, United States of America
Hüggenberg, R.	Gesellschaft für Nuklearbehälter mbH, Germany
Hughes, J.S.	National Radiological Protection Board, United Kingdom
Hussein, A.R.Z.	Egyptian Atomic Energy Authority, Egypt
Ikezawa, Y.	Institute of Radiation Measurements, Japan
Iwasawa, N.	Nippon Nuclear Fuel Company Ltd., Japan
Izumi, Y.	Ministry of Transport, Japan
Johnson, R.	United Kingdom Atomic Energy Authority, United Kingdom
Jutle, K.	Council for Nuclear Safety, South Africa
Kafka, G.	Federal Ministry for Science, Transport and Art, Austria
Kervella, O.	United Nations Economic Commission for Europe
Krazniak, M.	Nordion International, Canada
Laumond, A.	Electricité de France, France

Levin, I.	Nuclear Research Center Negev, Israel
Lopez Vietri, J.	Ente Nacional Regulador Nuclear, Argentina
Mairs, J.H.	International Atomic Energy Agency
Malesys, P.	Transnucléaire, France
McCulloch, N.	International Air Transport Association
McLellan, J.J.	Atomic Energy Control Board, Canada
Mezrahi, A.	Brazilian Nuclear Energy Commission, Brazil
Mori, R.	Nippon Nuclear Fuel Development Company Ltd., Japan
Mountford-Smith, T.	Nuclear Safety Bureau, Australia
Nakahashi, T.	International Atomic Energy Agency
Niel, J.-C.	Institut de Protection et de Sûreté Nucléaire, France
Nitsche, F.	Bundesamt für Strahlenschutz, Germany
Okuno, H.	Japan Atomic Energy Research Institute, Japan
Orsini, A.	Ente per le Nuove Tecnologie, l'Energia e l'Ambiente, Italy
O'Sullivan, R.A.	International Atomic Energy Agency
Parks, C.V.	Oak Ridge National Laboratory, United States of America
Pawlak, A.	National Atomic Energy Agency, Poland
Pecover, C.J.	Department of Transport, United Kingdom
Pettersson, B.	Nuclear Power Inspectorate, Sweden
Pitie, C.	Cogéma, France
Plourde, K.	Transport Canada, Canada
Pope, R.B.	Oak Ridge National Laboratory, United States of America; International Atomic Energy Agency

Rawl, R.R.	Oak Ridge National Laboratory, United States of America
Reculeau, J.-Y.	Institut de Protection et de Sûreté Nucléaire, France
Ridder, K.	Bundesministerium für Verkehr, Germany
Rödel, R.	Bundesanstalt für Materialforschung und -prüfung, Germany
Rooney, K.	International Civil Aviation Organization
Saegusa, T.	Central Research Institute of Electric Power Industry, Japan
Sannen, H.	Transnubel, Belgium
Schuurman, W.	International Federation of Air Line Pilots' Associations
Selby, J.	Richards Bay Minerals, South Africa
Sert, G.	Institut de Protection et de Sûreté Nucléaire, France
Shaw, K.B.	National Radiological Protection Board, United Kingdom
Shibata, K.	Power Reactor and Nuclear Fuel Development Corporation, Japan
Smith, L.	Swiss Federal Nuclear Safety Inspectorate, Switzerland; International Atomic Energy Agency
Svahn, B.	Swedish Radiation Protection Institute, Sweden
Taylor, M.	Atomic Energy Control Board, Canada
Trivellon, S.	Agenzia Nazionale per la Protezione dell'Ambiente, Italy
Tshuva, A.	Nuclear Research Center Negev, Israel
Usui, N.	Nuclear Safety Bureau Science and Technology Agency, Japan
van Gerwen, I.	Commission of the European Communities
van Halem, H.	Ministry of Housing and Physical Planning, Netherlands
Wang, J.	China Institute for Radiation Protection, China

Wangler, M.	United States Department of Energy, United States of America
Wiegel, G.	Swiss Federal Nuclear Safety Inspectorate, Switzerland
Wilson, C.K.	Department of Transport, United Kingdom
Wood, I.A.	Department of Transport, United Kingdom
Xavier, A.M.	Nuclear Energy Commission, Brazil
Yamasaki, T.	Ministry of Transport, Japan
Yasogawa, Y.	Nippon Kaiji Kentei Kayokai, Japan
Young, C.N.	Department of Transport, United Kingdom
Zamora, F.	Consejo de Seguridad Nuclear, Spain
Zeisler, P.	Bundesanstalt für Materialforschung und -prüfung, Germany

BODIES FOR THE ENDORSEMENT OF SAFETY STANDARDS

Nuclear Safety Standards Committee

Argentina: Sajaroff, P.; *Belgium:* Govaerts, P. (Chair); *Brazil:* Salati de Almeida, I.P.; *Canada:* Malek, I.; *China:* Zhao, Y.; *Finland:* Reiman, L.; *France:* Saint Raymond, P.; *Germany:* Wendling, R.D.; *India:* Venkat Raj, V.; *Italy:* Del Nero, G.; *Japan:* Hirano, M.; *Republic of Korea:* Lee, J.-I.; *Mexico:* Delgado Guardado, J.L.; *Netherlands:* de Munk, P.; *Pakistan:* Hashimi, J.A.; *Russian Federation:* Baklushin, R.P.; *Spain:* Mellado, I.; *Sweden:* Jende, E.; *Switzerland:* Aberli, W.; *Ukraine:* Mikolaichuk, O.; *United Kingdom:* Hall, A.; *United States of America:* Murphy, J.; *European Commission:* Gómez-Gómez, J.A.; *IAEA:* Hughes, P. (Co-ordinator); *International Organization for Standardization:* d'Ardenne, W.; *OECD Nuclear Energy Agency:* Royen, J.

Radiation Safety Standards Committee

Argentina: D'Amato, E.; *Australia:* Mason, C.G. (Chair); *Brazil:* Correa da Silva Amaral, E.; *Canada:* Measures, M.P.; *China:* Ma, J.; *Cuba:* Jova, L.; *France:* Piechowski, J.; *Germany:* Landfermann, H.-H.; *India:* Sharma, D.N.; *Ireland:* Cunningham, J.D.; *Japan:* Okamoto, K.; *Republic of Korea:* Choi, H.-S.; *Russian Federation:* Kutkov, V.A.; *South Africa:* Olivier, J.H.I.; *Spain:* Butragueño, J.L.; *Sweden:* Godås, T.; *Switzerland:* Pfeiffer, H.-J.; *United Kingdom:* Robinson, I.F.; *United States of America:* Cool, D.A.; *IAEA:* Bilbao, A. (Co-ordinator); *European Commission:* Kaiser, S.; *Food and Agriculture Organization of the United Nations:* Boutrif, E.; *International Commission on Radiological Protection:* Valentin, J.; *International Labour Office:* Nui, S.; *International Organization for Standardization:* Piechowski, J.; *OECD Nuclear Energy Agency:* Lazo, T.; *Pan American Health Organization:* Borrás, C.; *World Health Organization:* Souchkevitch, G.

Transport Safety Standards Committee

Argentina: López Vietri, J.; *Australia:* Mountford-Smith, T.; *Belgium:* Cottens, E.; *Brazil:* Bruno, N.; *Canada:* Aly, A.M.; *Chile:* Basaez, H.; *China:* Pu, Y.; *Egypt:* El-Shinawy, M.R.K.; *France:* Pertuis, V.; *Germany:* Collin, W.; *Hungary:* Sáfár, J.; *India:* Nandakumar, A.N.; *Israel:* Tshuva, A.; *Italy:* Trivelloni, S.; *Japan:* Tamura, Y.; *Netherlands:* van Halem, H.; *Poland:* Pawlak, A.; *Russian Federation:* Ershov, V.N.;

South Africa: Jutle, K.; *Spain:* Zamora Martin, F.; *Sweden:* Pettersson, B.G.; *Switzerland:* Knecht, B.; *Turkey:* Köksal, M.E.; *United Kingdom:* Young, C.N. (Chair); *United States of America:* Roberts, A.I.; *IAEA:* Pope, R.; *International Air Transport Association:* McCulloch, N.; *International Civil Aviation Organization:* Rooney, K.; *European Commission:* Rossi, L.; *International Maritime Organization:* Min, K.R.; *International Organization for Standardization:* Malesys, P.; *World Nuclear Transport Institute:* Bjurström, S.

Waste Safety Standards Committee

Argentina: Siraky, G.; *Australia:* Cooper, M.B.; *Belgium:* Baekelandt, L.; *Brazil:* Schirmer, H.P.; *Canada:* Ferch, R.; *China:* Xianhua, F.; *Finland:* Rukola, E.; *France:* Brigaud, O.; *Germany:* von Dobschütz, P.; *India:* Gandhi, P.M.; *Israel:* Stern, E.; *Japan:* Aoki, T.; *Republic of Korea:* Suk, T.W.; *Netherlands:* Selling, H.; *Russian Federation:* Poluehktov, P.P.; *South Africa:* Metcalf, P. (Chair); *Spain:* Gil López, E.; *Sweden:* Wingefors, S.; *Ukraine:* Bogdan, L.; *United Kingdom:* Wilson, C.; *United States of America:* Wallo, A.; *IAEA:* Delattre, D. (Co-ordinator); *International Commission on Radiological Protection:* Valentin, J.; *International Organization for Standardization:* Hutson, G.; *OECD Nuclear Energy Agency:* Riotte, H.

Commission for Safety Standards

Argentina: D'Amato, E.; *Brazil:* Caubit da Silva, A.; *Canada:* Bishop, A., Duncan, R.M.; *China:* Zhao, C.; *France:* Lacoste, A.-C., Gauvain, J.; *Germany:* Renneberg, W., Wendling, R.D.; *India:* Sukhatme, S.P.; *Japan:* Suda, N.; *Republic of Korea:* Kim, S.-J.; *Russian Federation:* Vishnevskij, Yu.G.; *Spain:* Martin Marquínez, A.; *Sweden:* Holm, L.-E.; *Switzerland:* Jeschki, W.; *Ukraine:* Smyshlayaev, O.Y.; *United Kingdom:* Williams, L.G. (Chair), Pape, R.; *United States of America:* Travers, W.D.; *IAEA:* Karbassioun, A. (Co-ordinator); *International Commission on Radiological Protection:* Clarke, R.H.; *OECD Nuclear Energy Agency:* Shimomura, K.

INDEX

(by base paragraph number or appendix number)

Acceleration values: Appendix V

Accident conditions: 106, 636, 671, 682, 726

Activity limits: 201, 230, 401, 411, 815–817, Appendix I, Appendix II

A₁: 201, 401, 403–406, 408–410, 416, 820

A₂: 201, 226, 401, 403–406, 408–410, 416, 549, 601, 605, 656, 657, 669, 730, 820

Air (transport by): 106, 416, 531, 576–578, 580, 617–621, 650, 652, 662, 680, 816, 817

Ambient conditions: 615, 617–619, 643, 651–653, 662, 664, 668, 676, 711, 728, 810, 831, 833

Basic Safety Standards: 304

Brittle fracture: Appendix VI

Carrier: 206, 311, 831

Categories of package: 533, 541, 543, 549, 573

Certificate of approval: 416–418, 502, 544, 549, 561, 565, 676, 801, 804, 805, 828, 830–834

Competent authority: 104, 204, 205, 207–209, 238, 301, 304, 310–312, 510, 537, 538, 544, 549, 565, 575, 582, 603, 632, 638, 665, 667, 676, 711, 801, 802, 804, 805, 813, 815–819, 821, 825, 828, 830–834

Compliance assurance: 208, 311

Confinement system: 209, 501, 678

Consignee: 221, 534, 581

Consignment: 204, 229, 236–238, 307, 309, 312, 401, 404, 505, 506, 529, 530, 546, 547, 549, 564, 566, 567, 570–572, 575, 576, 579, 580, 582, 672, 803, 824, 825, 831–833

Consignor: 221, 229, 310, 311, 505, 534, 549, 561, 580, 801, 831–833

Containment: 104, 618, 651

Containment system: 213, 228, 501, 502, 619, 630, 639, 640, 642, 643, 645, 648, 657, 660, 670, 677, 682, 714, 716, 724

Contamination: 214–216, 241, 508–510, 513, 520, 523, 656, 669

Conveyance: 104, 221, 223, 411, 510, 513, 514, 523, 525, 527, 566, 569, 606, 672, 831, 832

Cooling system: 577, 658

Criticality: 104, 209, 566–569, 716, 820, 831–833, Appendix VII

Criticality safety index: 218, 528–530, 544, 549, 566–569, 820, 831, 833

Customs: 581

Dangerous goods: 109, 506, 507, 562

Decontamination: 513

Dose: Appendix II

Dose limits: 302

Dose rates: Appendix II

Emergency: 308, 309, 831–833

Empty packaging: 520, 554

Excepted package: 222, 226, 230, 408–410, 514–520, 535, 541, 546, 549, 554, 575, 620, 649, 671, 672, 709, 802, 812, 815, 828

Exclusive use: 221, 505, 514, 523, 530–533, 540, 547, 549, 566, 567, 570–572, 574, 576, 652, 662

Exemption values: 107, 226, 236, 401, 403–406

Fissile material: 209, 218, 222, 226, 230, 418, 501, 502, 507, 515, 528, 541, 545, 549, 568, 569, 629, 671–682, 716, 732, 733, 802, 812, 813, 816, 817, 820, 828, 831–833, Appendix VII

Freight container: 218, 221, 223, 231, 243, 509, 514, 526, 527, 541–543, 545–547, 549, 562, 566, 568–570, 573, 627, 831, 832

Gas: 242, 642, 649

Half-life: Appendix II

Heat: 104, 501, 565, 603, 651, 704, 728, 831–833

Identification mark: 538, 549, 804, 828, 830–833

Industrial package: 230, 411, 521, 524, 525, 537, 621–628, 815, 828

Insolation: 617, 654, 662, 728

Inspection: 301, 310, 311, 502, 581, 801

Intermediate bulk container: 231, 504, 509, 514, 628

Label: 520, 538, 539, 541–546, 554, 570, 573

Leaching: 226, 603, 704, 711

Leakage: 510, 603, 619, 630, 632, 644, 648, 677, 680, 704, 711, 732, 733

Low dispersible radioactive material: 225, 310, 311, 416, 502, 549, 605, 663, 701, 712, 802–804, 828, 830–833

Low specific activity: 226, 243, 411, 521, 523–526, 540, 543, 547, 549, 566, 571, 601, 626, 701

Maintenance: 104, 106, 310, 311, 677, 832

Manufacture: 106, 310, 311, 677, 713, 816, 817, 831, 833

Marking: 507, 517, 518, 534, 540, 542

Mass: 240, 246, 418, 419, 536, 543, 549, 606, 608, 656, 672, 673, 682, 709, 722–724, 727, 735, 831, 833

Maximum normal operating pressure: 228, 660, 661, 668, 669

Multilateral approval: 204, 312, 718, 803, 805, 812, 816, 817, 820, 824, 828, 834

N: 528, 681, 682

Normal conditions: 106, 651, 681, 719

Notification: 204, 819

Operational controls: 228, 577, 666, 810, 825, 831–833

Other dangerous properties: 507, 541

Overpack: 218, 229, 243, 509, 514, 526, 527, 530, 531, 533, 541–543, 545, 549, 562, 565–570, 572–574, 578

Package design: 416–418, 537–539, 544, 549, 676, 801, 805, 810, 812, 816, 817, 828, 833

Packaging: 104, 106, 209, 213, 226, 230, 231, 310, 311, 520, 534–538, 554, 580, 609, 613, 629, 637, 645, 651, 663, 675, 677, 678, 701, 718, 723, 815–817, 819, 831–833

Placard: 546, 547, 570, 571

Post: 410, 515, 535, 579, 580

Pressure: 228, 231, 419, 501, 502, 619, 625, 631, 632, 639, 643, 644, 660, 661, 668, 669, 718, 729, 730

Pressure relief: 231, 631, 644

Quality assurance: 310, 803, 805, 813, 815–818, 830–833, Appendix IV

Radiation exposure: 243, 307, 562, 581

Radiation level: 104, 233, 306, 411, 510, 513, 516, 517, 521, 526, 527, 530–533, 566, 572, 574, 578, 605, 622, 624, 625, 627, 628, 646, 656, 669

Radiation protection: 301, 575, 603, 711, 802, 820

Rail (transport by): 242, 531, 570, 571

Responsibility: 103, 311

Road (transport by): 242, 531, 570–573

Routine conditions: 106, 215, 508, 518, 523, 566, 572, 612, 615, 625, 627, 679

Segregation: 306, 307, 562, 568, Appendix III

Serial number: 538, 816, 819

Shielding: 226, 231, 501, 523, 622, 624, 625, 627, 628, 646, 651, 656, 669, 716

Shipment: 204, 237, 501, 502, 549, 561, 572, 575, 674, 677, 802, 803, 820, 821, 824, 825, 828, 830–834

Shipping: 535, 549

Special arrangement: 238, 312, 531, 533, 544, 549, 574, 578, 824, 825, 828, 831

Special form: 201, 239, 310, 311, 416, 502, 549, 602–604, 640, 656, 701, 704, 709, 802–804, 818, 828, 830–833

Specific activity: 226, 240, Appendix II

Storage: 562, 564, 568

Stowage: 229, 311, 564, 565, 575, 831–833, Appendix V

Surface contaminated objects: 241, 243, 411, 504, 514, 521, 523–526, 540, 543, 547, 549, 571

Tank: 231, 242, 504, 509, 514, 526, 541, 542, 546, 547, 570, 625, 626

Tank container: 242

Tank vehicle: 242

Temperature: 228, 419, 502, 617, 637, 647, 652, 653, 662, 664, 668, 671, 675, 676, 709, 711, 728, 810, 831, 833

Tests: 502, 603, 605, 622, 624, 627, 628, 646, 648, 649, 651, 655, 656, 660, 668, 669, 675, 677–682, 701, 702, 704, 709, 711–713, 716, 717, 719, 725–727, 732, 734, 803

Tie-down: 231, 242, 636, Appendix V

Transport documents: 543, 549

Transport index: 243, 526, 527, 530, 533, 543, 549, 566, 567

Type A package: 230, 537, 634–640, 642–649, 725, 815, 828

Type B(M) package: 230, 416, 538, 576, 578, 665, 666, 730, 802, 810, 820, 828, 833

Type B(U) package: 230, 650–658, 660–664, 802, 828

Type C package: 230, 417, 501, 502, 538, 539, 667–670, 730, 734–737, 802, 828

Ullage: 419, 647

Unilateral approval: 205, 502, 803, 805, 828

United Nations number: 535, 546, 547, 549, 571

Unpackaged: 223, 243, 517, 521, 523, 525, 526, 547, 571, 672

Uranium hexafluoride: 230, 419, 526, 629–632, 677, 718, 802, 805, 828

Vehicle: 242, 537, 570–574, 828

Venting: 228, 231, 666, 820

Vessel: 531, 574, 575, 802, 820

Water: 106, 226, 525, 539, 601, 603, 605, 610, 657, 670, 671, 677, 678, 680–682, 711,
719–721, 726, 729, 730, 732, 733, 831, 833